

ROBE

iPainte® iPainte® POI iPainte® HCF

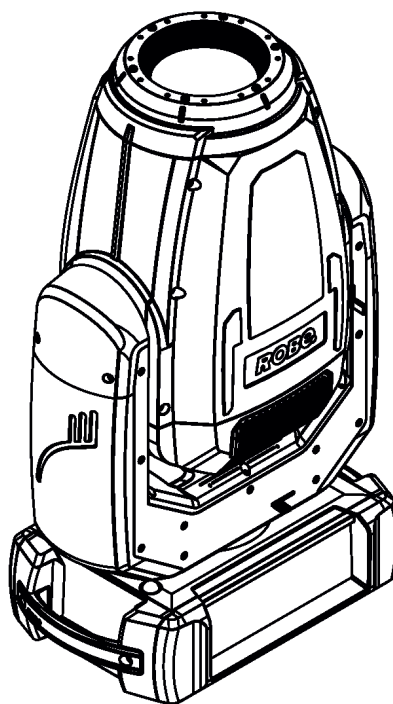

ROBE
Innovative
Technology

QR code for user manual



USER MANUAL

ROBE® lighting s.r.o. • Czech Republic • www.robe.cz

Version 1.5

Robin iPainte / iPainte HCF

Table of contents

1. Safety instructions and operating determinations.....	3
2. Fixture exterior view	6
3. Installation.....	7
3.1 Connection to the mains	7
3.2 Replacing the frost	10
3.3 Replacing rotating gobos	12
3.4 Rigging the fixture	14
3.5 DMX-512 connection.....	17
3.6 Ethernet connection	18
3.7 Wireless DMX operation	20
4. Checking the IP65 integrity of the fixture.....	21
5. Operating the fixture at ambient temperatures below 0°C	23
6. Standby mode.....	24
7. Remotely controllable functions.....	25
8. Control menu map.....	27
9. Control menu	31
9.1 Tab "Address"	34
9.2 Tab "Information"	34
9.3 Tab "Personality"	38
9.4 Tab "Manual Control".....	40
9.5 Tab "Stand-alone"	40
9.6 Tab "Service"	41
10. RDM	45
11. Error and information messages	46
12. NFC	50
13. Cleaning	50
14. Maintenance.....	51
14.1 Fixture watertight covers and torques of covers screws	53
14.2 Torques of Pan/Tilt motors screws.....	56
14.3 Changing the LED light source	57
14.4 Checking and replacing the silica gel desiccants	61
14.5 Disposing of the product.....	63
15. Obtaining information about the LED light source by mobile phone	64
16. Robe Ethernet Access Portal (REAP).....	66
17. Technical Specifications.....	74
18. ChangeLog	78

**FOR YOUR OWN SAFETY, PLEASE READ THIS USER MANUAL CAREFULLY
BEFORE YOU INITIAL START - UP**

This device has left our premises in absolutely perfect condition. In order to maintain this condition and to ensure a safe operation, it is absolutely necessary for the user to follow the safety instructions and warnings in this manual.

The manufacturer will not accept liability for any resulting damages caused by the non-observance of this manual or any unauthorized modification to the device.

Please consider that damages caused by manual modifications to the device are not subject to warranty.

The Robin iPainte was designed for outdoor use and it is intended for professional application only. It is not for household use.

1. Safety instructions and operating determinations

CAUTION!

Disconnect the fixture from mains before removing any cover of the fixture. With a high voltage you can suffer a dangerous electric shock when touching alive wires and electrical parts under covers!

Make sure that the available voltage is not higher than stated on the rear panel of the fixture. This fixture should be operated only from the type of power source indicated on the marking label. If you are not sure of the type of power supplied, consult your authorized distributor or local power company.

Always disconnect the fixture from AC power before cleaning, removing or servicing any part of the fixture.

The power plug has to be accessible after installing the fixture. Do not overload wall outlets and extension cords as this can result in fire or electric shock.

Do not allow anything to rest on the power cord. Do not locate this fixture where the cord may be damaged by persons walking on it.

Make sure that the power cord is never crimped or damaged by sharp edges. Check the fixture and the power cord from time to time.

Refer servicing to qualified service personnel.

This fixture falls under protection class I. Therefore this fixture has to be connected to a mains socket outlet with a protective earthing connection.

Do not connect this fixture to a dimmer pack.

During the initial start-up some smoke or smell may arise. This is a normal process and does not necessarily mean that the device is defective.

Do not focus the fixture beam onto flammable surfaces. The minimum distance between the front lens of the device and the illuminated surface must be greater than 3 meters.

***LED light emission. Risk of eye injury.
Do not look straight at the fixture's LED source during operation. The intense light beam may damage your eyes. Sensitive persons may suffer an epileptic shock.***

CAUTION! Risk group 2, RG-2
Avoid looking directly into the light source.



WARNING! This unit does not contain an ON/OFF switch. Always disconnect the power input cable from mains to completely remove power from unit when not in use or before cleaning or servicing the unit.

When choosing the installation spot, please make sure that the fixture is not exposed to extreme heat or dust.

Do not block the front glass cover with any object when the fixture is under operation.

The fixture becomes very hot during operation. Allow the fixture to cool approximately 30 minutes prior to manipulate with it.

Only operate the fixture after having checked that the housing is firmly closed and all screws are tightly fastened.

Always use a safety wire for overhead installation.

Make sure that the area below the installation place is blocked when rigging, derigging or servicing the fixture.

The maximum ambient temperature must never be exceeded.

CAUTION!
The front glass cover has to be replaced when it is obviously damaged, e. g. due to cracks or deep scratches!

Operate the device only after having familiarized with its functions. Do not permit operation by persons not qualified for operating the device. Most damages are the result of unprofessional operation!

CAUTION!
To avoid damage of the internal parts of the fixture head, never let the sunlight (or other light source) lights directly to the front glass cover, even when the fixture is not in operation !

Please use only an original ROBE packaging (paper box, loader case or foam shell) for transporting the device, otherwise potential damage of the device during its transport will not subject to warranty.

Do not touch the device's housing bare hands during its operation (housing becomes hot)!

For replacement use fuse of the same type and rating only.

The fixture housing never must be covered with cloth or other materials during its operation. Do not block fans or fans ventilation slots with any object. Fans and ventilation slots must remain clean.

The fixture must not come into contact with sea water (salt water). Damages or corrosion issues resulting from salt water will void the manufactures warranty and will not be subject to any warranty claims or repairs.

The product (covers and cables) must not be exposed to a high frequency electromagnetic field higher than 3V/m.

Immunity of the equipment is designed according to the standard EN 55035 Electromagnetic compatibility of multimedia equipment - Immunity requirements.

Emission of the equipment complies with the standard EN55032 Electromagnetic compatibility of multimedia equipment – Emission Requirements according to class B.

Contains FCC ID: 2A6PL-DMXRDMRW001

Contains IC: 29573-DMXRDMRW001

This device complies with part 15 of the FCC Rules. Operation is subject to the following two conditions: (1) This device may not cause harmful interference, and (2) this device must accept any interference received, including interference that may cause undesired operation.

Changes or modifications not expressly approved by the party responsible for compliance could void the user's authority to operate the equipment.

The [Device] wireless operation is safe and complies to RF Exposure requirements

This equipment has been tested and found to comply with the limits for a Class B digital device, pursuant to part 15 of the FCC Rules. These limits are designed to provide reasonable protection against harmful interference in a residential installation. This equipment generates, uses and can radiate radio frequency energy and, if not installed and used in accordance with the instructions, may cause harmful interference to radio communications. However, there is no guarantee that interference will not occur in a particular installation. If this equipment does cause harmful interference to radio or television reception, which can be determined by turning the equipment off and on, the user is encouraged to try to correct the interference by one or more of the following measures:

- Reorient or relocate the receiving antenna.
- Increase the separation between the equipment and receiver.
- Connect the equipment into an outlet on a circuit different from that to which the receiver is connected.
- Consult the dealer or an experienced radio/TV technician for help.

2. Fixture exterior view

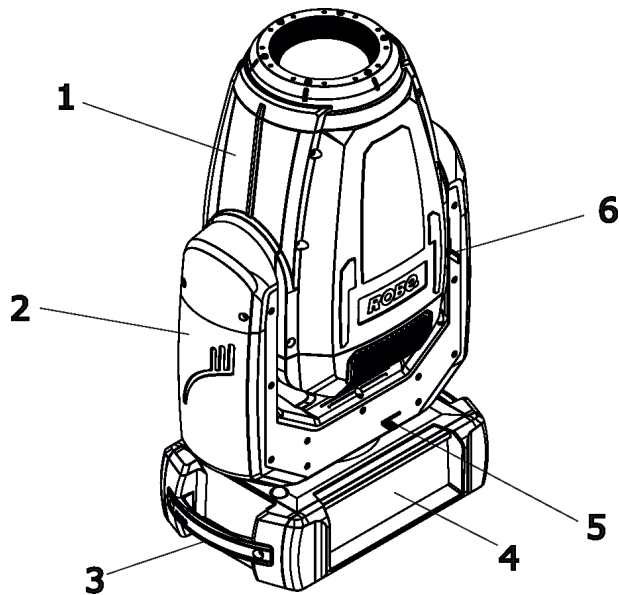

- 1 - Head
- 2 - Arm
- 3- Handle
- 4 - Base
- 5 - Pan lock
- 6 - Tilt lock

The head has to be locked for transportation - the tilt lock latch (6) and the pan lock latch (5) have to be in the locked positions. To unlock the head, move these latches to unlock position before operating the fixture.

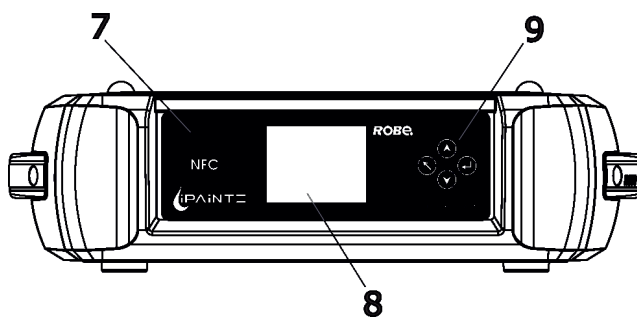

Front panel of the base

- 7 - NFC point
- 8 - Display
- 9 - Control buttons

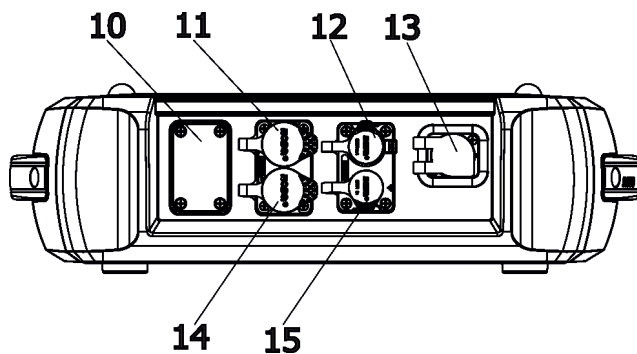

Rear panel of the base

- 10 - Cover of battery and fuse holder
- 11 - Ethernet Out (RJ45)
- 12 - DMX out (5-pin XLR)
- 13 - Power
- 14 - Ethernet In (RJ45)
- 15 - DMX in (5-pin XLR)

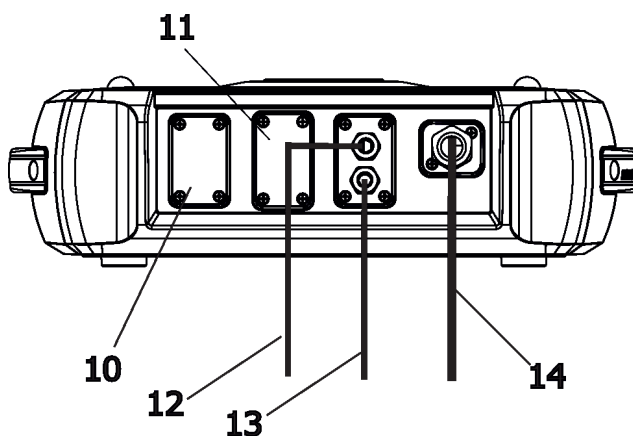

Rear panel of the base - POI version (POI = Permanent Outdoor Installation)

- 10 - Cover of battery and fuse holder
- 11 - Cover of Ethernet outputs
- 12 - DMX out
- 13 - DMX in
- 14 - Power

3. Installation



Fixtures must be installed by a qualified electrician in accordance with all national and local electrical and construction codes and regulations.

The Robin iPainte's panel connectors are dust and water protected according to IP 65 by mating with related cable connectors. They cannot stay disconnected outdoor.

All unused panel connectors have to be sealed by the rubber caps.

Visually check panel connectors on accidental water leaks before connecting related cable connectors.

If some water will appear in panel connectors, do not connect cable connectors, especially power!

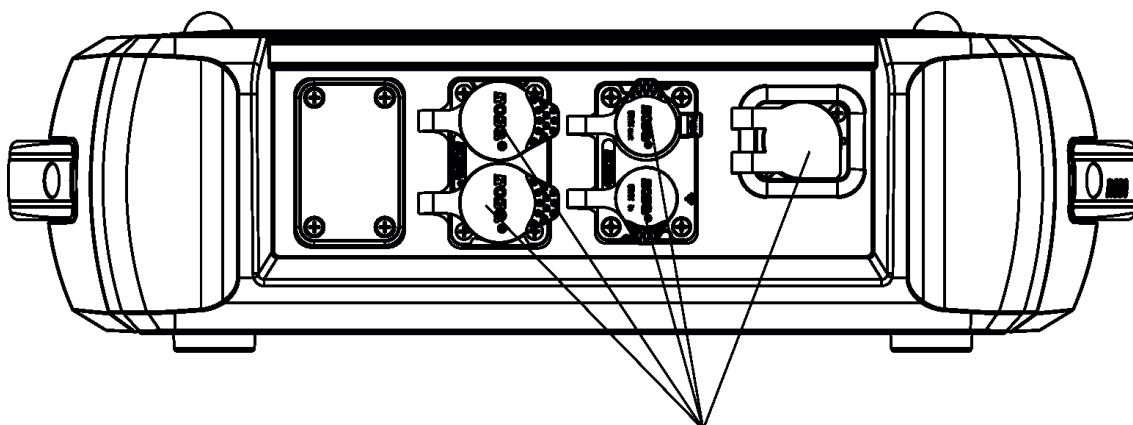

The rubber caps have to be placed on unused connectors.

The fixture must not come into contact with sea water (salt water).

3.1 Connection to the mains

To apply power, first check that the head pan and tilt locks are released.

**For protection from electric shock, the fixture must be earthed!
The fixture has to be connected to an electric outlet which is equipped with a residual-current device (residual-current circuit breaker)!**

Wiring and connection work must be carried out by a qualified electrician.

The Robin iPainte is equipped with auto-switching power supply that automatically adjusts to any 50-60Hz AC power source from 100-240 Volts.

Mains cable powerCON TRUE1 In/open ended is enclosed to the fixture. We recommend to install cord end-sleeves 1.5 x 8 (cross section in mm² x length in mm) on the cords of the mains cable. If you need to install a power plug on the mains cable to allow connection to power outlets, install a grounding-type (earthed) plug, following the plug manufacturer's instructions. If you have any doubts about proper installation, consult a qualified electrician. Connection to mains has to keep IP 65 protection rating.

Core (EU)	Core (US)	Connection	Plug Terminal Marking
Brown	Black	Live	L
Light blue	White	Neutral	N
Yellow/Green	Green	Earth	PE/GND

This device falls under class one and must be earthed (grounded).

Ensure all connections and the power plug on the cable are properly sealed.

POI version of the fixture - front side of the base

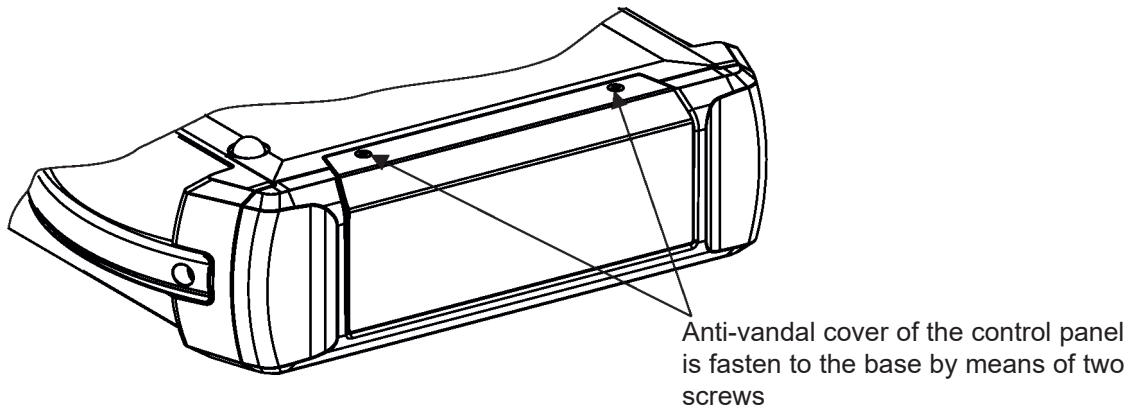

POI version of the fixture - variant 1

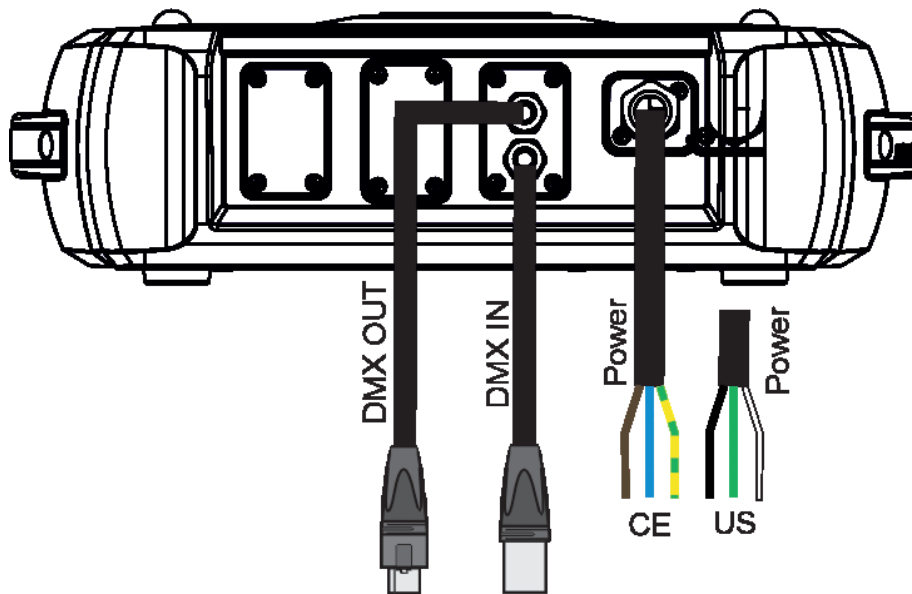

***Fixtures cable connectors are dust and water protected according to IP 65 by mating with related cable connectors. They cannot stay disconnected outdoor.
 All unused cable connectors have to be sealed by the rubber cap.
 Power cable cannot stay disconnected outdoor.
 Visually check cable connectors on accidental water leaks before connecting related cable connectors.
 If some water will appear in cable connectors, do not connect cable connectors.***

Connection to mains has to keep IP 65 protection rating.

Power (CE)

Wire	Function
Brown	Live
Blue	Neutral
Yellow/Green	⊕ (earth)

Power (US)

Wire	Function
Black	Live
White	Neutral
Green	⊕ (earth)

POI version of the fixture - variant 2

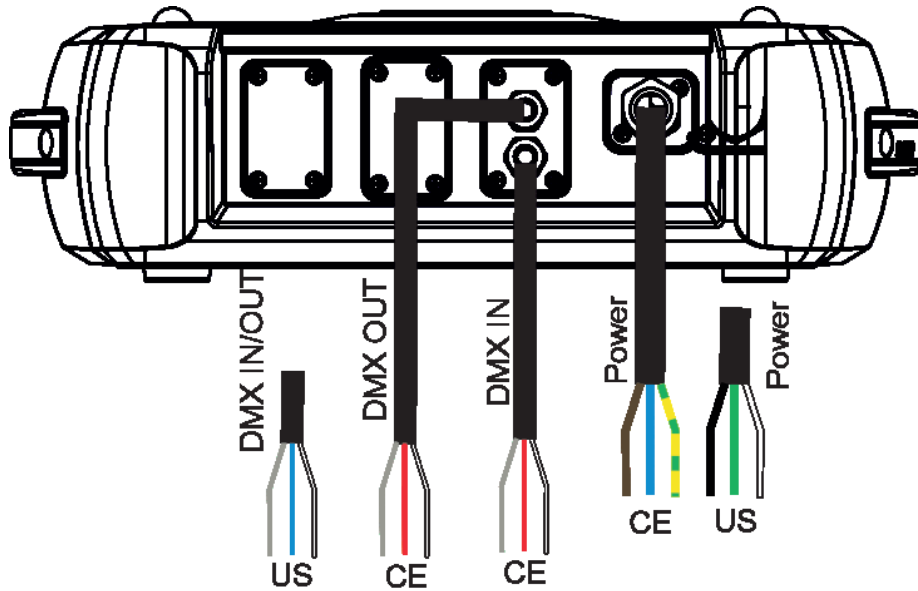

***Power and DMX cables cannot stay disconnected outdoor.
Connection to mains and connection to DMX have to keep IP 65 protection rating.***

Power (CE)

Wire	Function
Brown	Live
Blue	Neutral
Yellow/Green	⊕ (earth)

Power (US)

Wire	Function
Black	Live
White	Neutral
Green	⊕ (earth)

DMX (CE)

Wire	Function
Red	Data +
White	Data -
Shielding	Data ground

DMX (US)

Wire	Function
Blue	Data +
White	Data -
Shielding	Data ground

3.2 Replacing the frost

***Unplug the fixture from mains before replacing frost!
Do not replace frost in a damp environment (e.g. rain, snowfall)!
Do not remove fixture covers in smoky or particularly dirty
environment (e.g. with fog machines).***

To replace the frost.

1. Disconnect the fixture from mains and allow it to cool for 40 minutes.

2. Move the fixture head to the position as shown on the picture below (the pan and tilt locks have to be on the same side as the rear panel) to determine which top cover of the head has to be removed. Remove the top cover of the head by unscrewing 6 hex socket head screws M5x16 on the cover to get access to the frost.

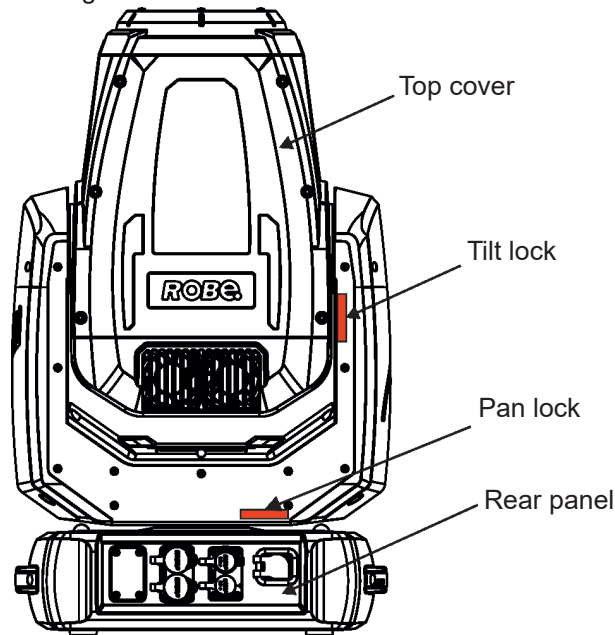

IMPORTANT: The fixture head should be uncovered as short time as possible (about 1-2 hours depending on air humidity) otherwise silica gel in the small boxes in the fixture head may become damp.

If you have removed head cover and you need to interrupt your work for long time (hours, days), we recommend to place the head cover on the head and fasten it provisionally by means of two screws, next possibility is unscrewing small boxes with silica gel from the head and put it to a sealed container with limited access of air (e.g. sealed plastic bag).

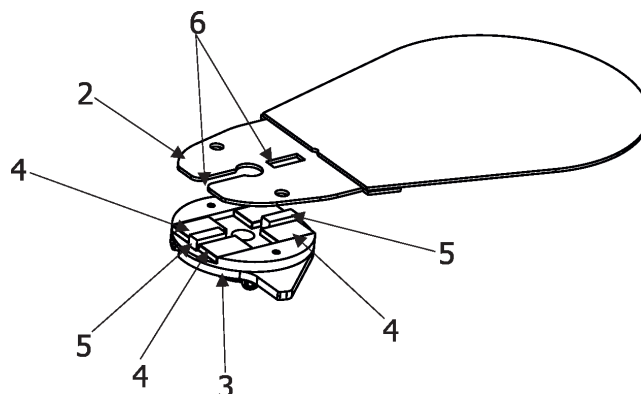

3. The holder (2) of the frost foil is fastened to the frost holder (3) by means of the four magnets (4). Grip the holder (2) and carefully tilt it out to break a force of magnets (4) on the frost holder (3).

4. Place a new frost module into the frost holder (3). Check, that both slots (6) snapped correctly into two protrusions (5) in the holder (3).

5. Check silica gel desiccants in the fixture head before placing head cover back on the fixture.

6. Place the head cover back on the fixture and screw it by means of the six hex socket head screws M5x16 before applying power. Keep required tightening torque as stated in the chapter Maintenance. Do not forget to connect grounding wire between chassis and the head cover.

7.Run the procedure Pressure Test (Service -->Pressure Test).

3.3 Replacing rotating gobos

***Unplug the fixture from mains before replacing the gobos!
Do not replace gobos in a damp environment (e.g. rain, snowfall)!
Do not remove fixture covers in smoky or particularly dirty
environment (e.g. with fog machines).***

To replace rotating gobos

1. Close a light output of the fixture and allow the fixture to cool about 40 minutes.
2. Move the fixture head to the position as shown on the picture below (the pan and tilt locks have to be on the opposite side in relation to the front panel) to determine which top cover of the head has to be removed. Remove the top cover of the head by unscrewing 6 hex socket head screws M5x16 on the cover.

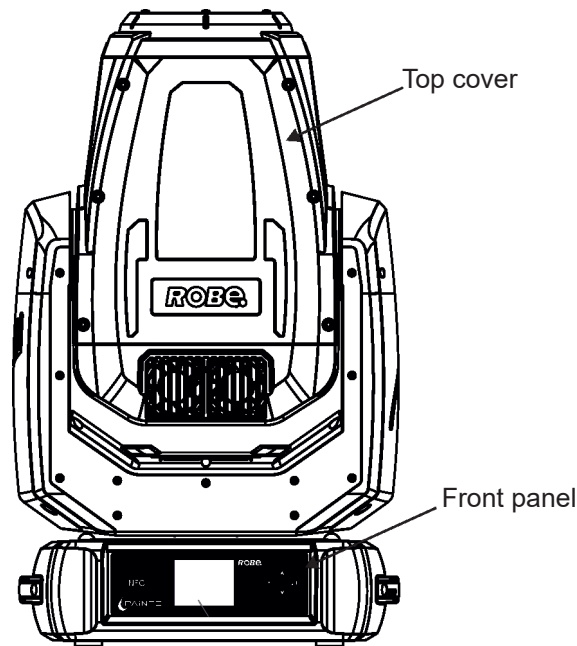

IMPORTANT: The fixture head should be uncovered as short time as possible (about 1-2 hours depending on air humidity) otherwise silica gel in the small boxes in the fixture head may become damp. If you have removed head cover and you need to interrupt your work for long time (hours, days), we recommend to place the head cover on the head and fasten it provisionally by means of two screws, next possibility is unscrewing small boxes with silica gel from the head and put it to a sealed container with limited access of air (e.g. sealed plastic bag).

3. Connect the fixture to mains. Go to the tab "Service", select the menu "Adjust DMX values " and move the fixture head to the position which is suitable for changing rot. gobos.
4. Escape from the menu "Adjust DMX values " and go to the menu " Rotating Gobos Change" in the same tab, select menu Gobo Carousel and enter the menu.
5. Select a gobo (G1-Mg, G2, G3, G4, G5, G6, G7,G8) which you wish to replace. The selected gobo will move to the accessible position for its changing.
Note: "G1-Mg" means the gobo holder with a magnet (7).

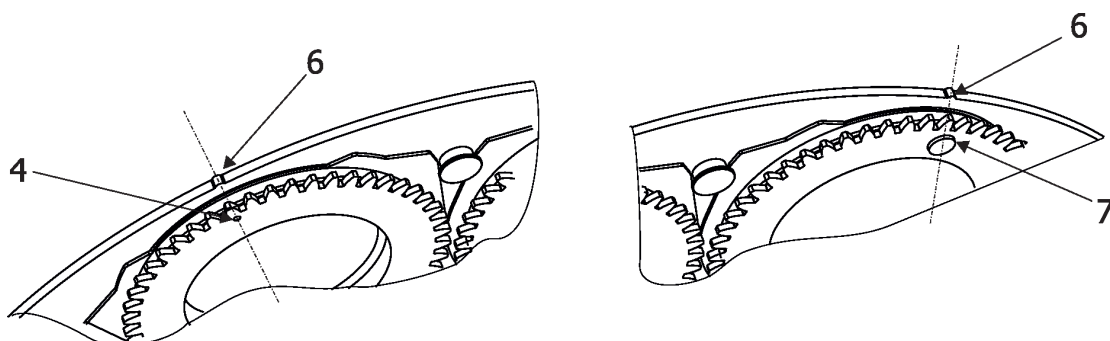

6. Check that the position point (4) on the gobo holder aims exactly to the toothlike projection (6) on the edge of the rotating gobo wheel. If not, go to the option "Gobo Offset" and adjust the position point (4) exactly opposite of the toothlike projection(6). Adjusted value in the "Gobo Offset" is valid for all gobos on the gobo carousel.

Note: The magnet (7) on the gobo holder substitutes the position point (4).

7. Gently pull up the gobo holder (3) from the rotation gobo carousel.

8. Remove the spring lock (1) with an appropriate tool (e.g. small-bladed screwdriver).
Do not touch the surface of the glass gobo with bare fingers.

9. Remove the original gobo (2) and insert the new one (grey side towards the light source, black side towards the front lens).

The Robe gobo has a small position point (5) at its edge which has to aim at the position point (4) on the gobo holder (3). Insert the spring lock (1) to secure correct gobo position in the gobo holder (3).

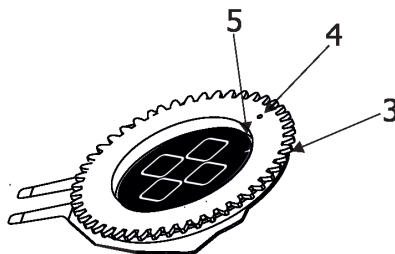
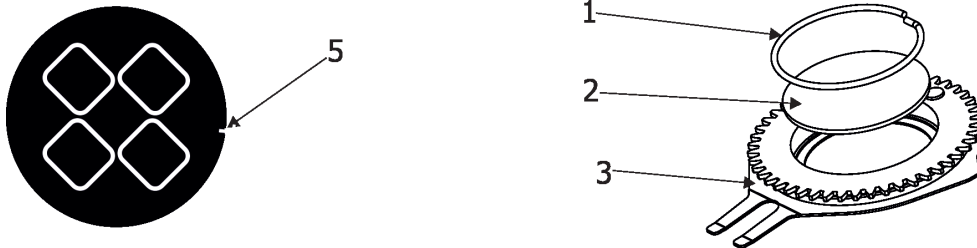

10. Insert the gobo holder back into gobo carousel in this way, that its position point (4) (or magnet (7)) has to exactly aim at a small toothlike projection (6) on the edge of the rotating gobo wheel. Do not move with neighbouring gobo holders.

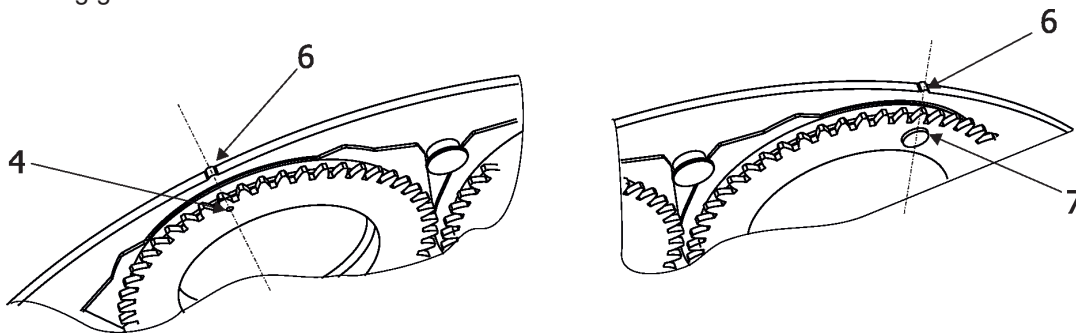

11. Escape the gobo item and enter another gobo item which you want to replace. You do not need to set the gobo offset again. Repeat steps 5-10 for all gobos which you need to replace on the gobo carousel.

12. **After replacing desired gobos, connect the fixture to mains and light on changed gobo holders (or gobos) with max. intensity (shutter/dimmer=255 DMX) approximately 10 minutes per each changed gobo position to evaporate potential grease from gobo holders and gobos.**

During this procedure, the fixture head has to be in a horizontal position without top cover (side of fixture head without cover has to be up) and the gobo has to rotate.

Note: this step you can leave out if you use original gobo holders from the fixture and you sure that new glass gobos are clean.

13. Check silica gel desiccant in the fixture head before placing head cover back on the fixture.

14. Place the head cover back on the fixture and screw it by means of the six hex socket head screws M5x16. Keep required tightening torque as stated in the chapter Maintenance.

Do not forget to connect grounding wire between chassis and head cover.

15. **Run the procedure Pressure Test (tab Service -->Pressure Test).**

3.4 Rigging the fixture

A structure intended for installation of the fixture(s) must safely hold weight of the fixture(s) placed on it. The structure has to be certificated to the purpose.

The fixture (fixtures) must be installed in accordance with national and local electrical and construction codes and regulations.

For overhead installation, the fixture must be always secured with a safety wire that can bear at least 10 times the weight of the fixture

When rigging, derigging or servicing the fixture staying in the area below the installation place, on bridges, under high working places and other endangered areas is forbidden.

The operator has to make sure that safety relating and machine technical installations are approved by an expert before taking into operation for the first time and after changes before taking into operation another time.

The operator has to make sure that safety relating and machine technical installations are approved by a skilled person once a year.

Allow the fixture to cool for ten minutes before handling.

The fixture should be installed outside areas where persons may walk by or be seated.

IMPORTANT! OVERHEAD RIGGING REQUIRES EXTENSIVE EXPERIENCE, including calculating working load limits, installation material being used, and periodic safety inspection of all installation material and the projector. If you lack these qualifications, do not attempt the installation yourself, but use a help of professional companies.

CAUTION: Fixtures may cause severe injuries when crashing down! If you have doubts concerning the safety of a possible installation, do not install the fixture!

The fixture has to be installed out of the reach of public.

The fixture must never be fixed swinging freely in the room.

***Danger of fire !
When installing the device, make sure there is no highly inflammable material (decoration articles, etc.) in a distance of min. 0.5 m.***

***CAUTION!
Use 2 appropriate clamps to rig the fixture on the truss.
Follow the instructions mentioned at the bottom of the base.
Make sure that the device is fixed properly! Ensure that the structure (truss) to which you are attaching the fixtures is secure.***

The fixture can be placed directly on the stage floor or rigged on a truss without altering its operation characteristics .

For securing the fixture to the truss, install a safety wire which can hold at least 10 times the weight of the fixture. Use only the safety wire with a snap hook with screw lock gate.

Omega holders points

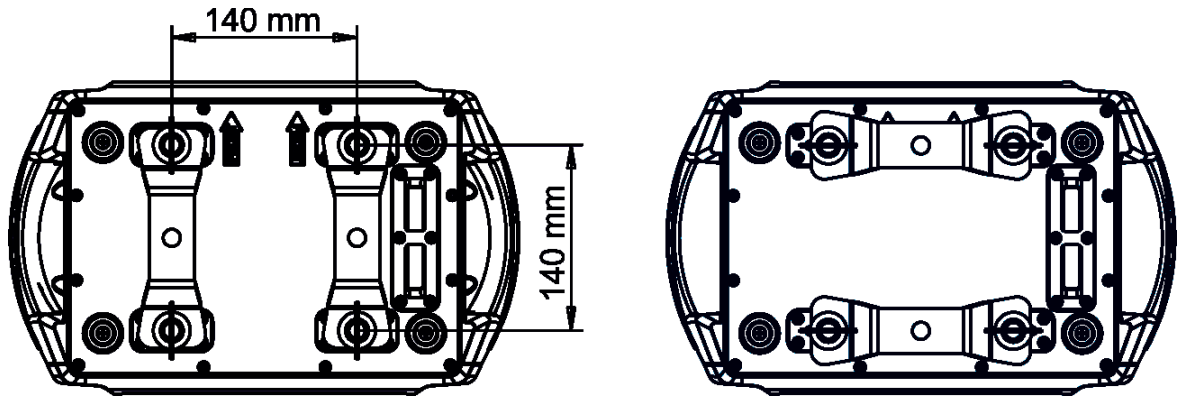

Truss installation

1. Bolt Clamps (4) to the Omega adaptors (1) with M12 bolts and lock nuts through the hole in the Omega adaptors
2. Fasten the Omega adaptors on the bottom of the base by means of the quick-lock fasteners (2) and tighten them fully clockwise.
3. Install the fixture on the truss.
4. Pull a safety wire (3) through the carrying handle and the truss (6) as shown on the picture below in a suitable position so that the maximum fall of the fixture will be 20 cm. Fasten a snap hook in the attachment point (5). Use only the safety wire with a snap hooks with screw lock gates.

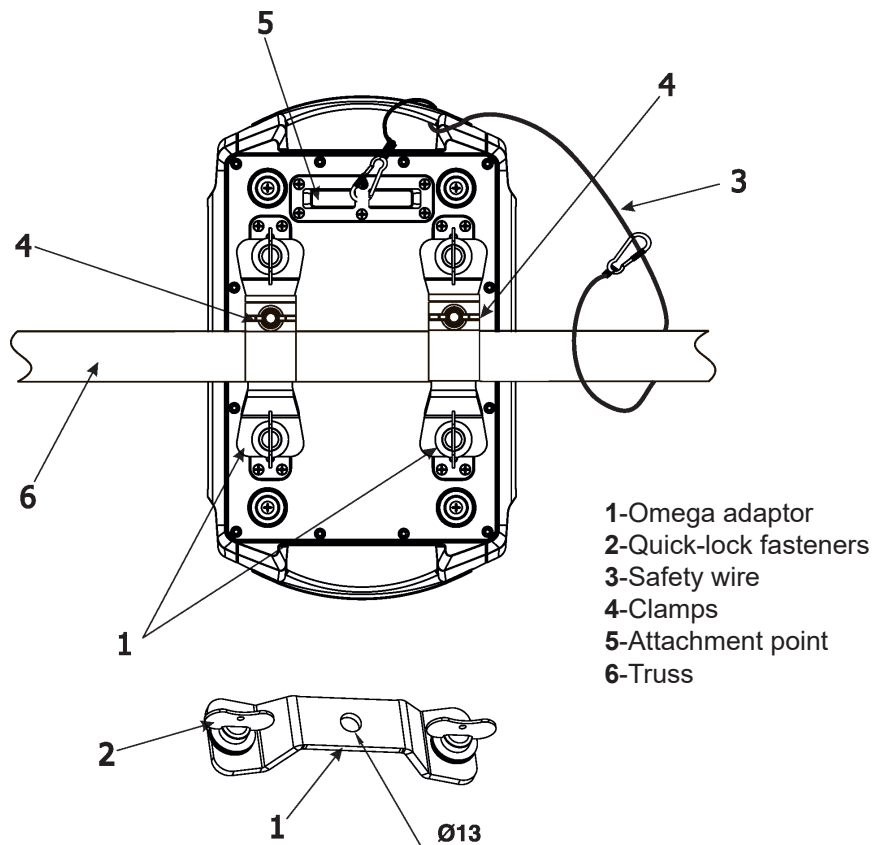

Note:

Surface corrosion of the Omega adaptors may occur, especially if this fixture has been used outdoors. Surface corrosion will not affect the safety of the Omega adaptors. Omega adaptors corrosion is not covered by the warranty.

***When installing fixtures side-by-side,
avoid illuminating one fixture with another!***

DANGER TO LIFE!
Before taking into operation for the first time, the installation has to be approved by an expert!

Allowed installation positions of the iPainte:

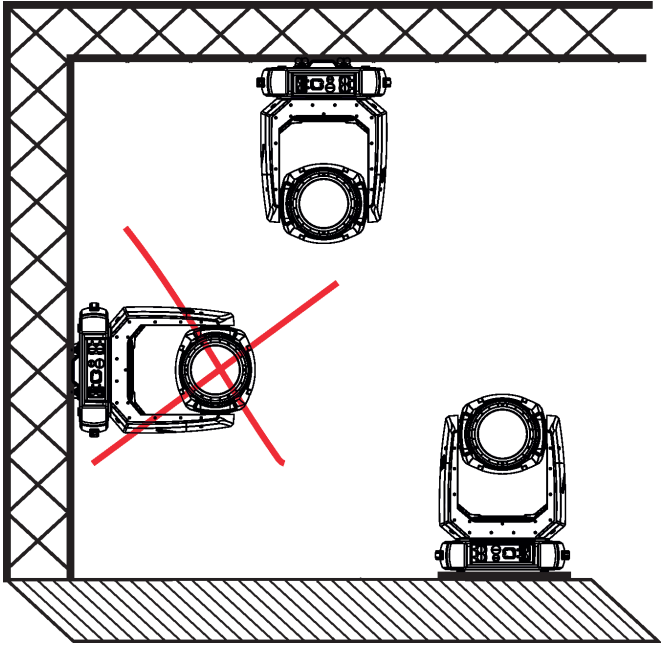

Note for open-air installation: if the fixture has to stand on the ground, min. distance of 4" (10cm) between the fixture base and the ground has to be kept.

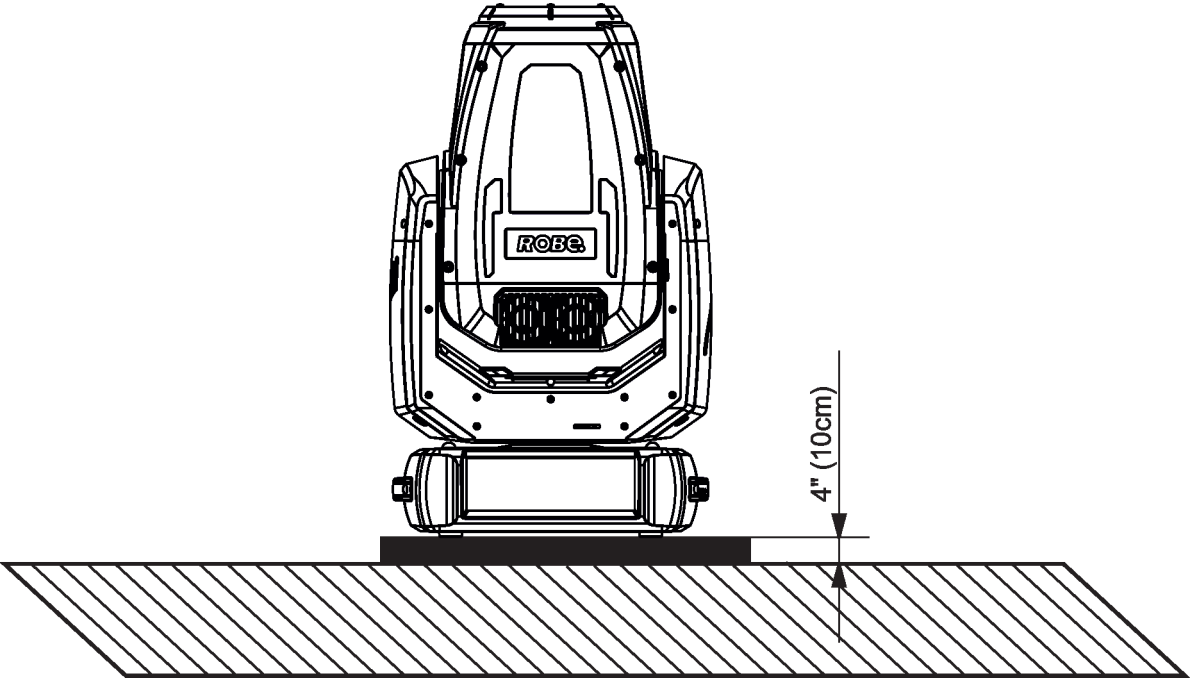

3.5 DMX-512 connection

The fixture is equipped with 5-pin XLR sockets for DMX input and output. Use a shielded twisted-pair cable designed for RS-485 and 5-pin XLR-plugs and connectors in order to connect the controller with the fixture or one fixture with another.

DMX output

XLR mounting sockets (rear view):

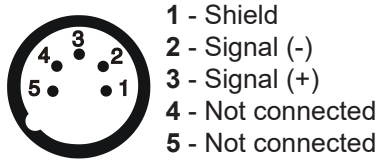

DMX input

XLR mounting plugs (rear view):

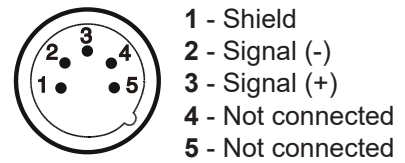

If you are using the standard DMX controllers, you can connect the DMX output of the controller directly with the DMX input of the first fixture in the DMX chain. If you wish to connect DMX controllers with other XLR outputs, you need to use adaptor cables.

Building a serial DMX chain:

Connect the DMX output of the first fixture in the DMX chain with the DMX input of the next fixture. Always connect one output with the input of the next fixture until all fixtures are connected. Up to 32 fixtures can be connected.

Caution: At the last fixture, the DMX cable has to be terminated with a terminator. Solder a 120 Ω resistor between Signal (-) and Signal (+) into a 5-pin XLR plug and plug it in the DMX output of the last fixture.

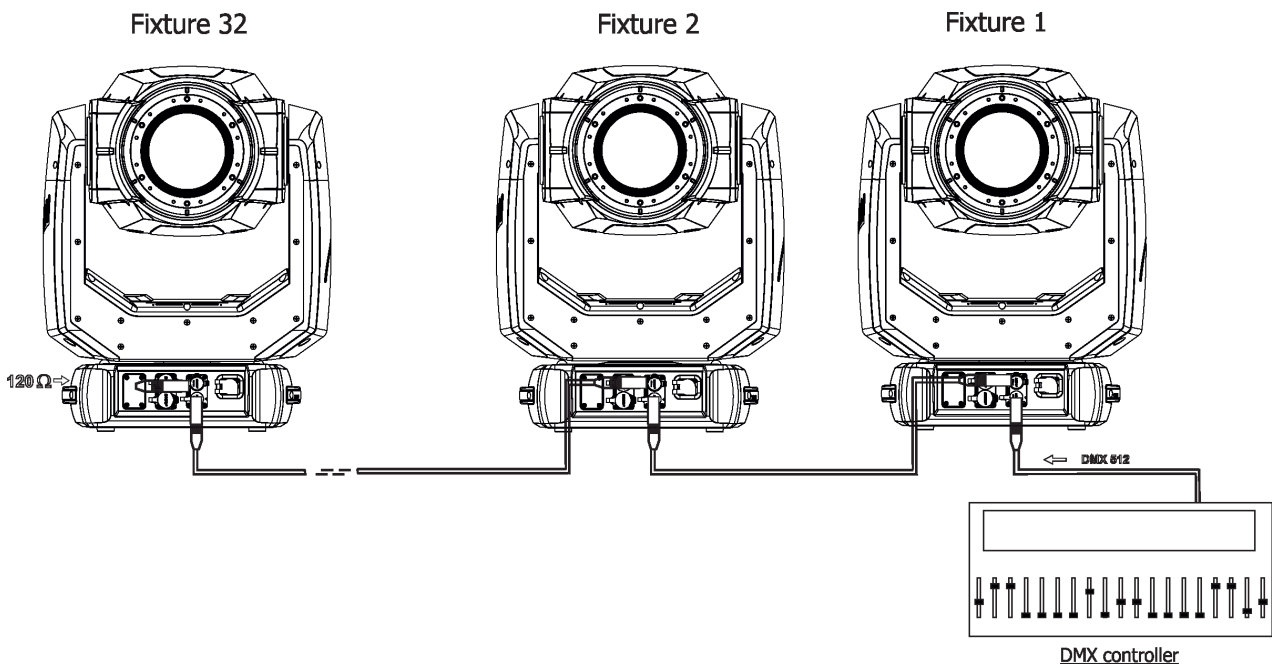

3.6 Ethernet connection

The fixtures on a data link are connected to the Ethernet with appropriate communication protocol (e.g. Art-Net). The control software running on your PC (or light console) has to support Art-Net protocol.

Art-Net communication protocol is a 10 Base T Ethernet protocol based on the TCP/IP. Its purpose is to allow transfer of large amounts of DMX 512 data over a wide area using standard network technology.

IP address is the Internet protocol address. The IP uniquely identifies any node (fixture) on a network.

The Universe is a single DMX 512 frame of 512 channels.

The Robin iPainte is equipped with 8-pin RJ-45 sockets for Ethernet connection. Use a network cable category 5 (with four “twisted” wire pairs) and standard RJ-45 plugs in order to connect the fixture to the network.

RJ-45 socket (front view):

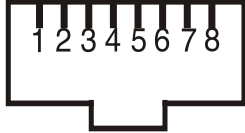

- 1- TD+
- 2- TD-
- 3- RX+
- 4- Not connected
- 5- Not connected
- 6- RX-
- 7- Not connected
- 8- Not connected

RJ-45 plug (front view):

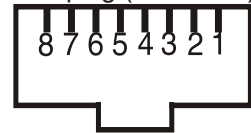

Patch cables that connect fixtures to the hubs or LAN sockets are wired 1:1, that is, pins with the same numbers are connected together:



If only the fixture and the computer are to be interconnected, no hubs or other active components are needed. A cross-cable has to be used:



If the fixture is connected with active Ethernet socket (e.g. switch) the network icon  will appear at the bottom right corner of the screen:

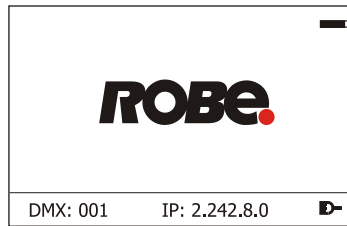

Ethernet operation

Connect the Ethernet inputs of all fixtures with the Ethernet network.

Option “Artnet” (gMal or gMA2 or sACN) has to be selected from “Ethernet Mode” menu at each fixture.

Set IP address (002.xxx.xxx.xxx / 010.xxx.xxx.xxx) and the Universe at each fixture.

(DMX address=221)
IP address=002.168.002.004
Universe=1

(DMX address=45)
IP address=002.168.002.003
Universe=1

(DMX address=1)
IP address=002.168.002.002
Universe=1

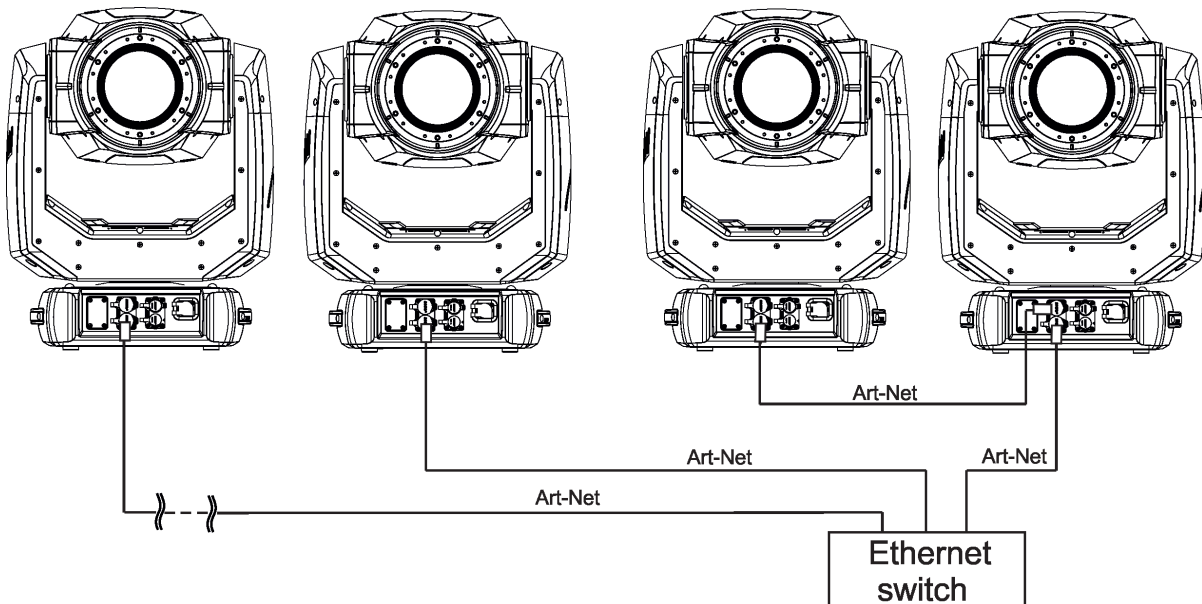

An advised PC setting: IP address: 002.xxx.xxx.xxx (Different from fixture IP addresses)
NET mask: 255.0.0.0

The fixture is equipped with Ethernet Pass through switch which sustains Ethernet integrity, when the fixture has no power, it automatically maintains network connectivity.

If you use the Ethernet IN-OUT way for the Ethernet connection, max. 8 fixtures can be connected in the IN-OUT line.

Ethernet / DMX operation

Option "Artnet" (gMal or gMA2 or sACN) has to be selected from "Ethernet Mode" menu at first fixture.

Option "Ethernet To DMX" has to be selected from the "Ethernet Mode" menu at the first fixture (connected to the Ethernet) in the fixture chain, next fixtures have standard DMX setting.

Connect the Ethernet input of the first fixture in the data chain with the network. Connect the DMX output of this fixture with the input of the next fixture until all fixtures are connected to the DMX chain.

Caution: At the last fixture, the DMX chain has to be terminated with a terminator. Solder a 120 Ω resistor between Signal (-) and Signal (+) into a XLR-plug and connect it in the DMX-output of the last fixture.

Example:

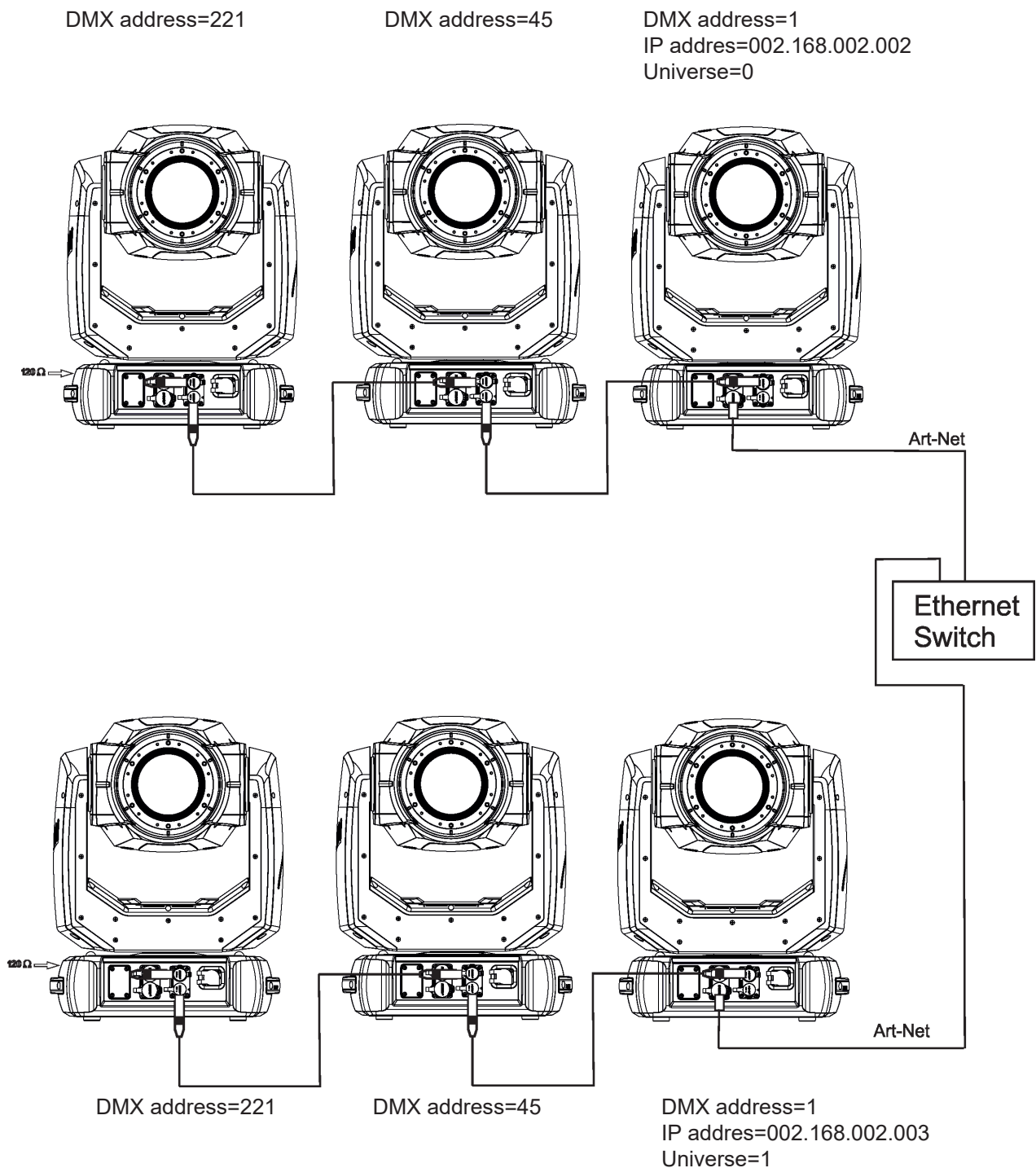

3.7 Wireless DMX operation

The ROBE wireless DMX/RDM module has full support for wireless communication protocols at entertainment market. Module is based on well known LumenRadio RF technology, with implemented wire interface for connection with Robe products. RF output for MCX interface antenna as standard output.

The item " Wireless " from the menu "DMX Input" allows you to activate receiving of wireless DMX (Personality--> DMX Input -->Wireless.). First two options from the "DMX Input" menu are stated in DMX chart as well (channel Power/Special functions , range of 10-19 DMX). If DMX input option is changed by DMX command, the change is permanently written into fixture's memory.

DMX range of 10-19 switching fixture to the wired/wireless operation is active only during first 10 seconds after switching the fixture on.

After switching the fixture on, the fixture checks both modes of receiving DMX in the following order:

1. For the first five seconds, the fixture receives DMX signal from the wired input. If the Power/Special functions channel is set at some DMX input option, the fixture will receive DMX value according to this option. If DMX input option is set to the wired input , this option is saved and checking procedure is finished. If DMX input option is not set, the fixture continues next 5 seconds in scanning wireless DMX signal-see point 2.

2. For the next 5 seconds the fixture receives wireless DMX signal and again detects if the Power/Special functions channel is set at some DMX input option, if not, the fixture will take option which is set in the fixture menu "DMX Input".

To link the fixture with DMX transmitter.

The fixture can be only linked with the transmitter by running the link procedure at DMX transmitter . After linking , the level of DMX signal (0-100 %) is displayed in the menu item "Wireless State" (Information -->Wireless State).

To unlink the fixture from DMX transmitter.

The fixture can be unlinked from transmitter via the menu item " Unlink Wireless Adaptor" (Information--> Wireless State --> Unlink Wireless Adaptor).

Note: If the option "Wireless In/XLR Out" is selected (Personality--> DMX Input -->Wireless In/XLR Out), the fixture receives wireless DMX and sends the signal to its wired DMX output. The fixture behaves as " Wireless/Wired" adaptor.

Example of connection:

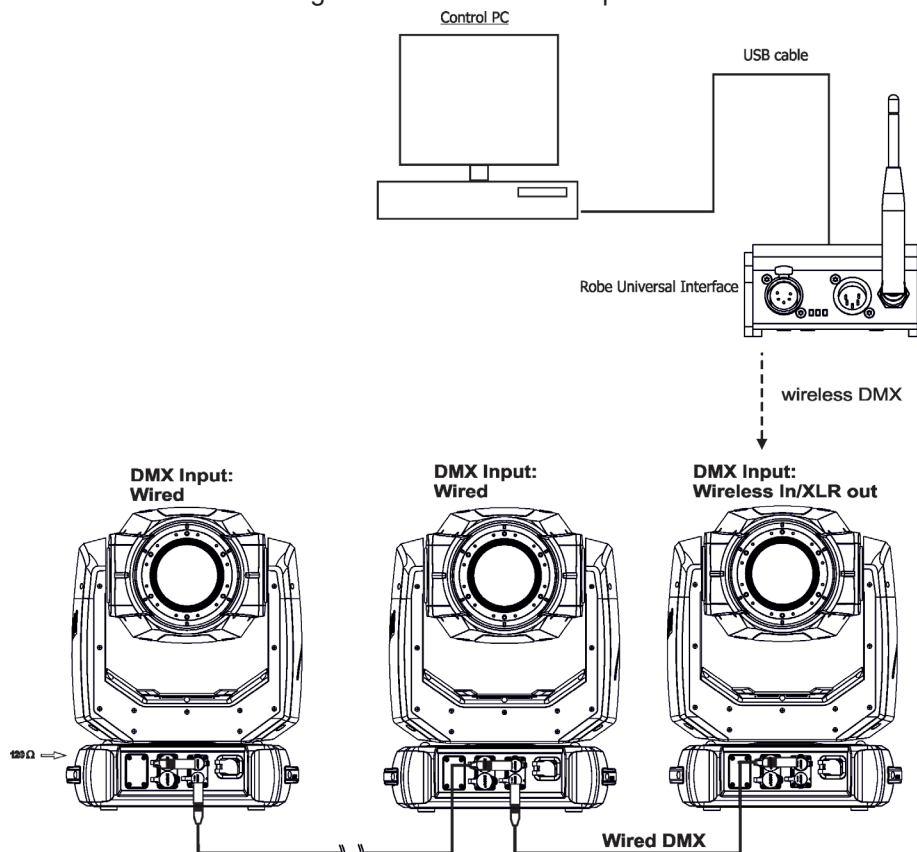

4. Checking the IP65 integrity of the fixture.

The Robin iPainte is IP65 rated lighting fixture which has been designed to be protected against the ingress of dust and pressure water jets from any direction.

1. Smart pressure test - for this test serves the function "Pressure Test" in the tab Service. Unique testing procedure allows you easy testing of the IP65 integrity of the fixture. You do not need any external device connected to the fixture for running the test.

The fixture has to be connected to mains (must not be in Standby mode) and a head temperature (at pressure sensor) cannot be higher than 55°C. The pressure test takes about 8 minutes and can be run at earliest 10 minutes after closing light output of the fixture. The pressure test can be repeated at earliest 2 minutes after last pressure test.

The function "Pressure Test" should be run after the following actions:

- **unscrewing/screwing back any watertight cover** (e.g. due to gobos or frosts change)
- **replacing pan or tilt motor**
- **replacing LED light source**
- **replacing desiccants in the fixture arm (two tubes with silica gel).**

The pressure test can be also run by DMX command (channel Power/Special function) or from web interface REAP (Robe Ethernet Access Portal). During the pressure test fixture does not respond to DMX commands (except DMX values 38-39 on the channel Power/Special functions).

Examples of screens (front panel display) of the smart pressure test:

Fixture waits for 10 minutes period elapsing (inside of the fixture is too hot)

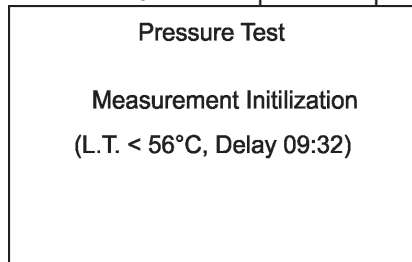

Fixture waits for 2 minutes period elapsing (pressure test was repeated too early)

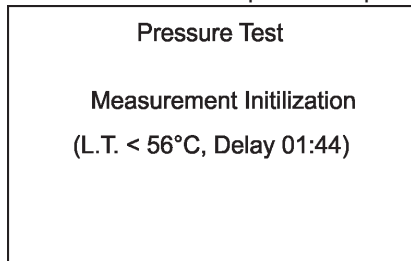

Setting fans

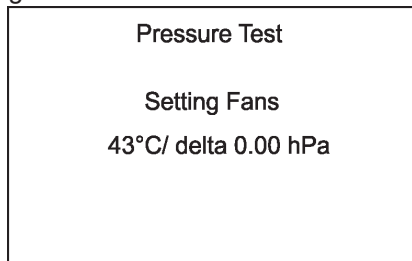

Test in progress

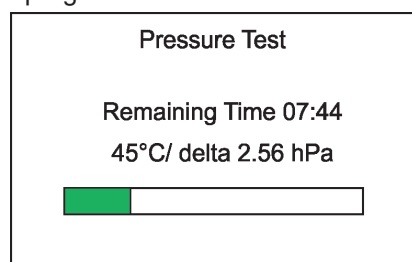

Legend:

07:44Remaining Time (minutes) to finish of pressure test.
45°C.....Temperature at pressure sensor.
delta 2.56 hPa...Pressure difference.
The pressure difference has to be >7 hPa for successful test.

Test passed

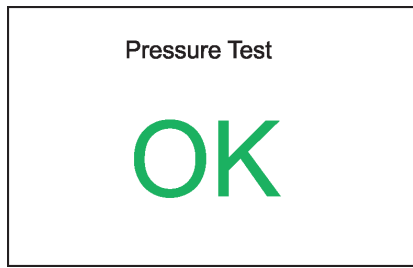

Test failed

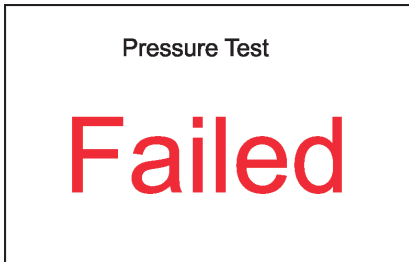

If the first pressure test failed and the second is OK, the fixture complies with IP65 integrity. If the pressure test twice fails despite checking of correct tightening of the cover screws and gaskets under covers, the fixture has to be tested by means of "Enhanced pressure test". For this type of pressure test is needed the Pressure IP Testing Set ROBE (P/N 10980659). Please ask your ROBE distributor for help.

The message "Valve Seal Error" means that valve or coil in the valve is defective or there is a connection problem.

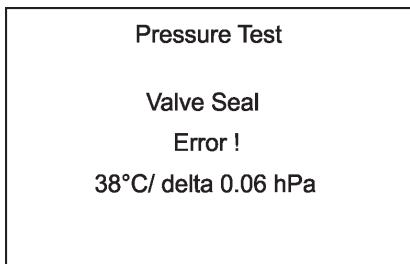

Check the connection between the valve and head, especially cable connector. Other reason can be faulty coil in the valve or faulty valve.



Cable connector
(arm without tilt lock)

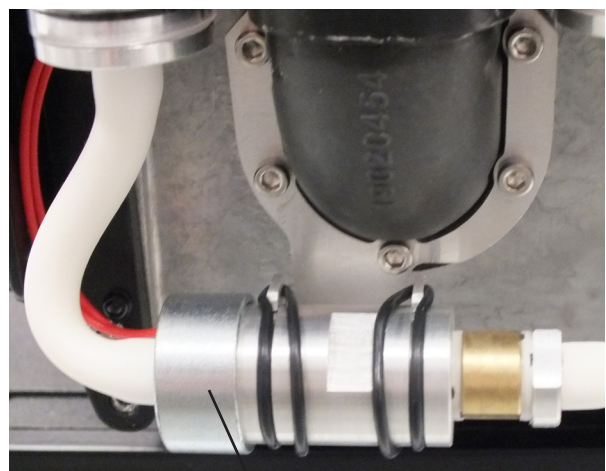

Valve
(arm without tilt lock)

The message "Not Available At The Moment" means that the fixture is not connected to mains.

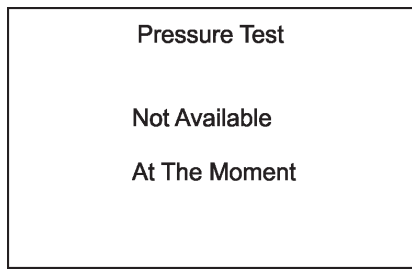

2. Enhanced pressure test - a special equipment Pressure IP Testing Set ROBE (P/N 10980659) is intended for this kind of pressure test. Only trained technician should handle the equipment.

Pressure IP Testing Set ROBE
in case:

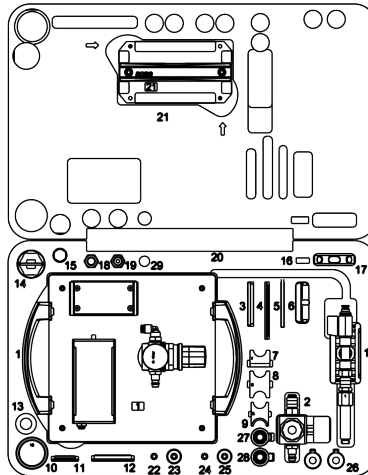

If this equipment is used for pressure test of the fixture, the following values of pressure have to be kept:

Underpressure test.

300 mbar for 1 minute, pressure fall can be to 10 mbar maximally.

Overpressure test

150 mbar maximally!

5. Operating the fixture at ambient temperatures below 0°C

Design of the iPainte allows its operation at ambient temperature up to -30°C, but you have to take some specific into account before operating the fixture.

1. Fixture is not in Standby mode.

iPainte - ambient temperatures from 0°C to -10°C.

The fixture can be switched off but after powered it on, fixture reset can be delayed in range of 0 - 30 minutes depending on ambient temperature (max. delay is at low ambient temperature). This delay is caused by heating fixture effects on operating temperature. The fixture does not respond to DMX during heating the fixture on operating temperature.

We recommend to switch the fixture on at least 30 minutes before show.

iPainte - ambient temperatures from -11°C to -30°C.

The fixture should be permanently powered on in order to keep operating temperature of fixture's effects. If the fixture is switched off, reset of the fixture will last long time (up to 1 hour depending on ambient temperature) until fixture effects reach their operating temperature.

2. Fixture is in Standby mode.

If the fixture is switched to Standby mode (fixture has to be connected to mains), the fixture keeps internal temperature on a level suitable for operation of fixture's effects without delay, heating up of the fixture inside is done automatically.

6. Standby mode

The fixture can be switched to Standby mode by means of web interface REAP or DMX command (channel Power/Special functions, DMX values 6-7).

Standby mode can be cancelled by means of web interface REAP, DMX command (channel Power/Special functions, DMX values 8-9) or by switching the fixture off and on.

Standby mode helps conserve power when a fixture is not in use, without fully powering it off. The max. power consumption of the fixture in Standby mode does not exceed 20 W (if the fixture is heated, power consumption is higher). Standby mode is indicated by a notice on the fixture display.

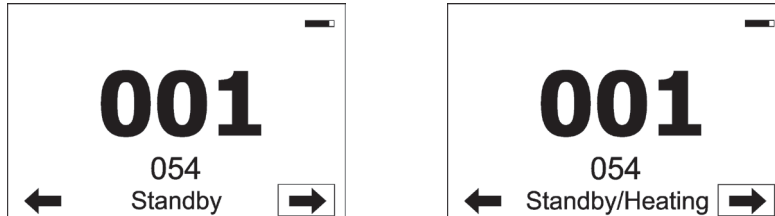

In the Standby mode, the fixture display is functional and can be used for setting of the fixture, but all motors and fans are deactivated, light output is closed.

As the fixture motors are deactivated, the fixture does not respond to DMX values controlling effects but the channel Power /Special functions can be used for fixture settings.

The fixture in Standby mode provides information for RDM and REAP and also can be set its behaviour by means of the RDM and REAP.

Main benefits of Standby mode:

- there is not time delay of fixture reset at ambient temperatures below 0°C.
- By means of REAP user has current information about fixture (settings, temperatures, state of desiccants in the fixture arm).

7. Remotely controllable functions

Colour wheel

The colour wheel with 9 dichroic filters rotates in both directions with variable speed which creates wide spectrum of graphic effects.

CMY colour mixing system

The CMY color mixing system is based on graduated cyan, magenta, and yellow colour filters. A continuous range of colors may be achieved by varying the amount of each filter from 0 to 100%.

Rotating gobo wheel

The rotating gobo wheel includes 8 glass gobos rotating in both directions, indexable, replaceable "SLOT&LOCK" system.

Static gobo wheel

The static gobo wheel includes 9 metal gobos. Gobo positioning and continual gobo positioning is available as well as a gobo-shake function.

Prism

The 8-facet radial prism rotates in both directions at different speeds.

Framing system

Framing system consists of four framing shutters. There is individual control of each shutter blade position and angle, together with rotation of the complete framing module. As well as providing a sharp precise or soft frame for the projected image.

Framing system orientation:

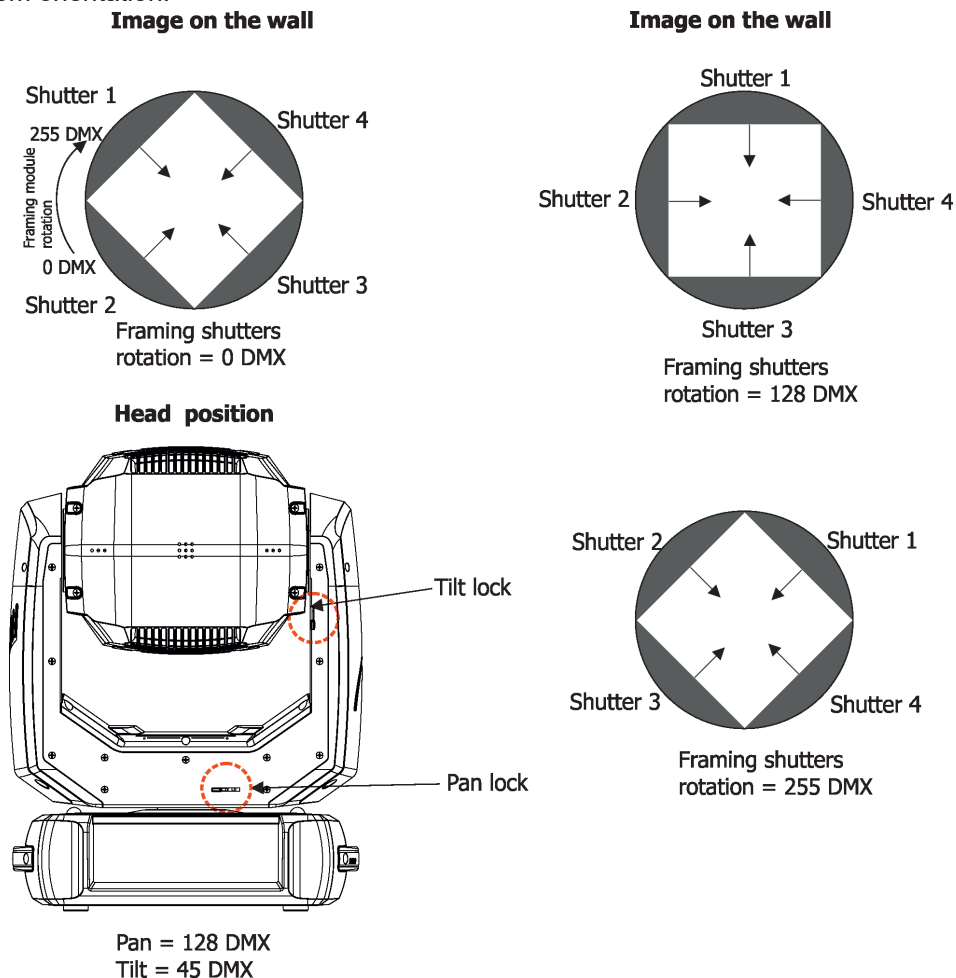

Pan/Tilt

Fast pan/tilt movement due to built-in electronic motion stabilizer (EMS). The electronic motion stabilizer ensures precise position of the fixture's head during its movement and reduces its swinging when the truss shakes. Pan /Tilt movement range: 0-540°/0-270°.

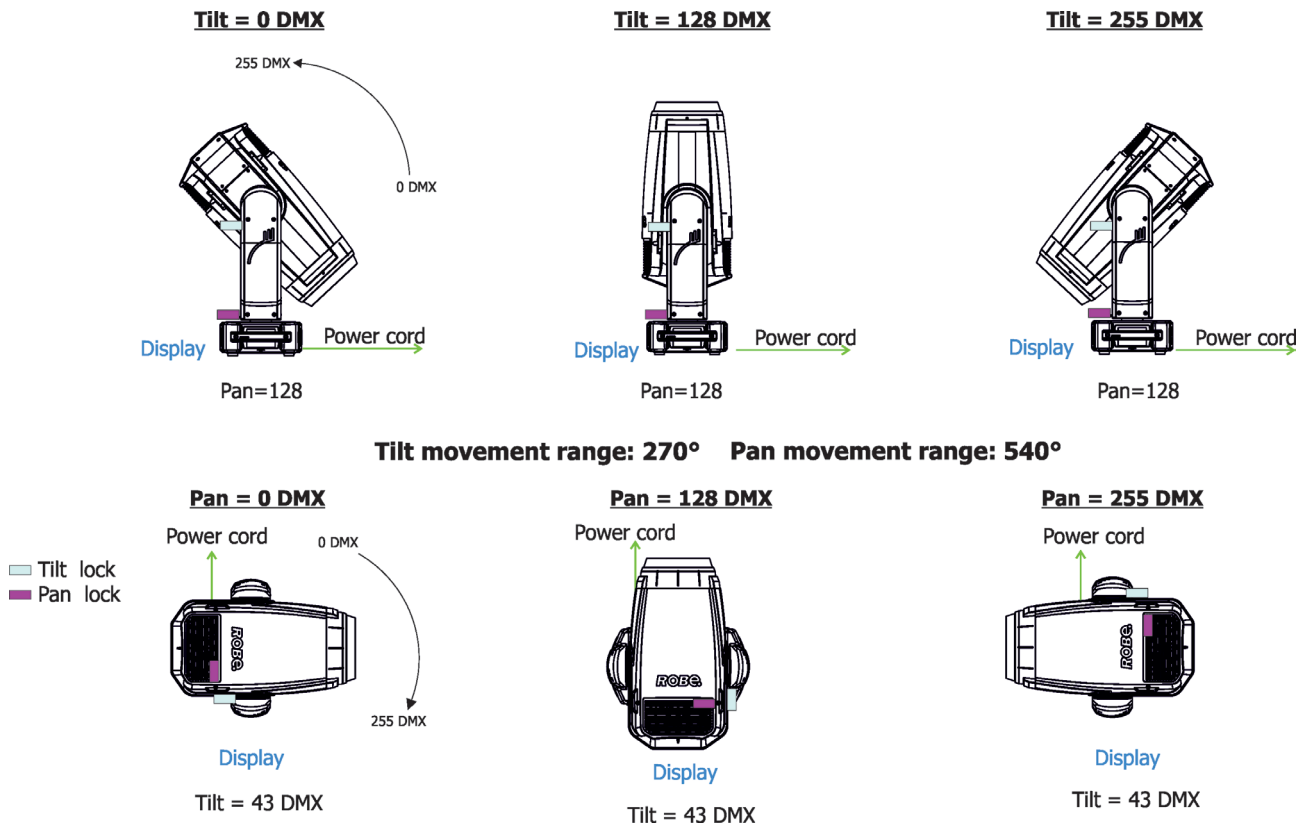

Frost filter



Installed 5° frost filter provides variable frost for fine frosting.

8. Control menu map

Default settings=**Bold print**

Tab	Level 1	Level 2	Level 3	Level 4	Level 5	Level 6
Addressing	DMX Address	001-512				
	DMX Presets	Mode 1				
		Mode 2				
	Ethernet Settings	Ethernet Mode	Disable			
			ArtNet			
			gMAI			
			gMA2			
			sACN			
		Ethernet To DMX	Off , On			
		IP Address/Net Mask	Default IP Address			
			Custom IP Address			
			Net Mask			
		ArtNet Universe	0-255			
		MANet settings	MANet/II Universe	01-256		
			MANet Session ID	01-32		
		sACN Settings	sACN Universe	00001-32000		
		Ethernet as Backup	Disable			
			Enable			
Information	Fixture Times	Power On Time	Total Hours			
			Resetable Hours			
	Fixture Temperatures	LEDs Temperature	Current			
			Maximum NonRes..			
			Maximum Res..			
		Driver Temperature	Current			
			Maximum NonRes..			
			Maximum Res..			
		Base Temperature	Current			
			Maximum NonRes.			
			Maximum Res.			
	RAINS Status					
	Sensors Info					
	DMX Values	Pan				
		:				
		Dimmer Fine				
	Wireless State	Signal Quality				
		Unlink Wireless Adapter				
	Power Channel state					
	Software Versions	Display System				
		Module M				
		Module L				
		Module O				
		Module F-A				
		Module F-B				
		Module G				
		Module C				
		Module P				
		Module DL				
		Wireless				

Tab	Level 1	Level 2	Level 3	Level 4	Level 5	Level 6
	Product IDs	Mac Address				
		RDM UID				
		RDM Label				
	LED Module info	First Module Assembly				
		Actual Module Info				
		Assembly History				
		Intensity History				
	LED Modules History					
	View Logs	Fixture Errors				
		Fixture States	Power On			
			Power Off			
		Fixture Position				
		Fixture Temperatures	LEDs Temperature			
			Driver Temperatures			
			Base Temperatures			
		Sensors Logs				
		Pressure Test Logs				
Personality	User Mode	User A Settings				
		User B Settings				
	DMX Presets	Mode 1				
		Mode 2				
	DMX Input	Wired				
		Wireless				
		Wireless In/XLR Out				
	Pan/Tilt Settings	Pan Reverse	Off, On			
		Tilt Reverse	Off, On			
		Pan/Tilt Feedback	Off, On			
		Pan/Tilt mode	Time			
			Speed			
	Pan/Tilt EMS	Off, On				
	Pan/Tilt Limitation	Pan Min. Value	0-255			
		Pan Max. Value	0-255			
		Tilt Min. Value	0-255			
		Tilt Max. Value	0-255			
	Blackout Settings	Blackout During M.C.	Off, On			
		Blackout while:	Pan/Tilt moving	Off, On		
			Colour Wheel Moving	Off, On		
	Frequency Setup	300 Hz				
		600Hz				
		1200Hz				
		2400Hz				
		Frequency Adjust				
	Init Effect Positions	Pan	0-255			
		:				
		Dimmer Fine	0-255			
	Reset Effect Positions					
	Screen Settings	Display Intensity	1-10			
		Screen Saver Delay	Off-10min.			
		Touchscreen Lock	Off-10min.			
		Recalibrate Touchscreen				
		Display Orientation	Normal			
			Inverted			
			Auto			
	Temperature Unit	°C, °F				

Tab	Level 1	Level 2	Level 3	Level 4	Level 5	Level 6
	Fan Settings	Fan mode	Auto			
			High			
			Quiet			
		Quiet - Blackout Fan Off	On, Off			
	Dimmer Curve	Linear				
		Square Law				
		Super Square Law				
	Gobo Indexing	Max. Speed & ShortCut				
		Follow Speed & Direction				
		Max. Speed & ShortCut				
	Date & Time Settings					
	Focus Tracking	Off, On				
	Default Settings					
	Password Protection	Off, On				
	Reset Web Password					
Manual Control	Reset Functions	Total System Reset				
		Pan/Tilt reset				
		Color System Reset				
		Gobo/Eff. Wh. Reset				
		Optics/Prism/Frost Res.				
		Iris/framing Sh. Reset				
	Manual Effect Control	Pan	0-255			
		:				
		Dimmer Fine	0-255			
Stand -Alone	Test Sequences	Dynamic Mode				
		Static Mode	Pan	0-255		
			Tilt	0-255		
			Zoom	0-255		
			Focus	0-255		
	Preset Playback	None				
		Test				
		Prog. 1				
		Prog. 2				
	Play Program	Play Program 1				
		Play Program 2				
	Edit Program	Edit Program 1	Start Step	1-80		
		Edit Program 2	End Step	1-80		
			Edit Program Steps	Step 1	Pan	0-255
				:	:	
				:	Dimmer Fine	0-255
				:	Step Time	0-25,5 sec.
				Step 80	Pan	0-255
					:	
					Dimmer Fine	0-255
					Step Time	0-25,5 sec.
Service	Pressure Test					
	Adjust DMX Values	Pan	0-255			
		:				
		Dimmer Fine	0-255			
	Calibrations	Calibrate Effects	Pan	0-255		
			Tilt	0-255		
			Rot. Gobo Wheel	0-255		
			R. Gobo Index 1	0-255		

Tab	Level 1	Level 2	Level 3	Level 4	Level 5	Level 6
			:	:		
			R. Gobo Index 8	0-255		
			Static Gobo	0-255		
			Colour Wheel	0-255		
			Cyan	0-255		
			Magenta	0-255		
			Yellow	0-255		
			Prism 1	0-255		
			Prism 2	0-255		
			Prism Rotation	0-255		
			Zoom	0-255		
			Focus	0-255		
			Iris	0-255		
			Frost 1	0-255		
			Frost 2	0-255		
			Fr. Shutters rot.	0-255		
			Fr. Shutter 1 Move	0-255		
			Fr. Shutter 1 Swiv	0-255		
			Fr. Shutter 2 Move	0-255		
			Fr. Shutter 2 Swiv	0-255		
			Fr. Shutter 3 Move	0-255		
			Fr. Shutter 3 Swiv	0-255		
			Fr. Shutter 4 Move	0-255		
			Fr. Shutter 4 Swiv	0-255		
		Calibrate Fr. Shutters	Fr. Shutters rot.	0-255		
			Fr. Shutter 1 Move	0-255		
			Fr. Shutter 1 Swiv	0-255		
			Fr. Shutter 2 Move	0-255		
			Fr. Shutter 2 Swiv	0-255		
			Fr. Shutter 3 Move	0-255		
			Fr. Shutter 3 Swiv	0-255		
			Fr. Shutter 4 Move	0-255		
			Fr. Shutter 4 Swiv	0-255		
		Calibrate Fr. Hysteresis	Framing Lamella 1	0-8		
			Framing Lamella 2	0-8		
			Framing Lamella 3	0-8		
			Framing Lamella 4	0-8		
		Calibrate CMY Offsets	Cyan			
			Magenta			
			Yellow			
		Calibrate Pan/Tilt EMS				
		Calibrate Pan/Tilt Reset				
		Load Default Calibrations				
	Rotating Gobos Change	Gobo Carousel 1	G1-Mg, G2...G8			
			Gobo Offset			
	LEDs Measure					
	Update Software					



9. Control menu

The Robin iPointe65 is equipped with the QVGA screen with battery backup and four control buttons which allow you to set the fixture's behaviour according to your needs, obtain information on its operation, test its various parts and program it, if it has to be used in a stand-alone mode. The fixture supports NFC (Near-Field Communication).

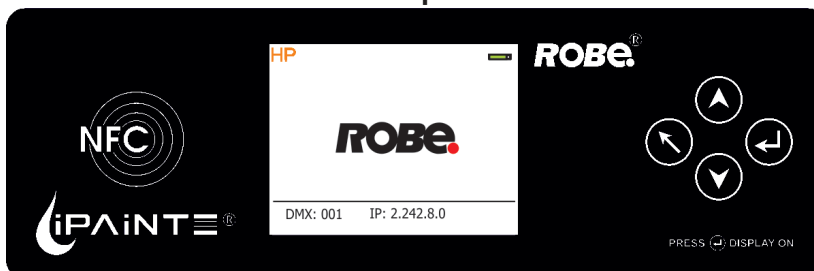











NFC interface and control buttons on the front panel



Control buttons on the front panel:

-  - [ESCAPE] button used to leave the menu without saving changes.
-  - [NEXT] , [PREV] buttons for moving between menu items and symbols, adjusting values.
-  - [ENTER/Display On] button used to enter the selected menu item and to confirm adjusted value. If the fixture is disconnected from mains, the button switches the screen on (for a while).

Icons used in the screen menu:

-  - [back arrow] used to move back to the previous screen (menu).
-  - [up arrow] used to move up on the previous page.
-  - [down arrow] used to move down on the next page.
-  - [confirm] used to save adjusted values, to leave menu or to perform desired action.
-  - [cancel] used to leave menu item without saving changes.
-  - [confirm+copy] used to save adjusted values and copy them to the next prog. step.
-  - [warning icon] used to indicate some error which has occurred in the fixture.
-  - [Ethernet] used to indicate Ethernet connected.
-  - [menu rotation] used to rotate menu 180 degrees from current orientation.
-  - [slider control] used to recall slider system for setting desired value.
-  - [keyboard control] used to recall keyboard system for setting desired value.
-  - [QR code] used to show QR code for RDM UID of the fixture and LED engine serial number.

The menu page displays icons for each function that you can perform from the screen. After switching the fixture on, the screen shows the screen with the ROBE logo. Type of used LED engine in the fixture is displayed on the top line of the screen.

HP-type of LED engine used in the fixture.

-20% is a drop of max. light intensity set by the channel "Max. light intensity indication and setting".

Note: drop 0-5% is not signalized.

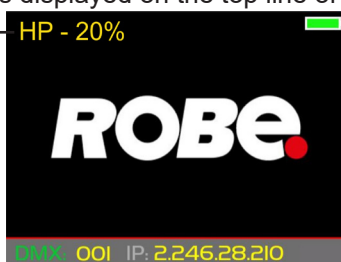

Battery indication

HP - High Performance Engine for maximum light output and optimal colour characteristics.

HCF - High Colour Fidelity Engine for the best light quality and colour reproduction.

The type of used LED engine is displayed if the fixture is disconnected from power as well.

The green icon at the top right corner of the screen indicates the level of the display battery charging. If the whole icon is green, the battery is fully charged while the red icon indicates exhausted battery. The battery charges during fixture operation, its charging lasts cca 6 hours.

We recommend that the fixture should be in operation at least 7 hours per week to keep the battery fully charged. If you switch the fixture on and this screen will not appear till 1 minute, switch the fixture off and on again. If the screen lights, the battery is exhausted. In case the screen still does not light, the battery is faulty.

This is also indicated by an error message "Faulty battery" and if such an error message appears the battery should be replaced immediately. The lifetime of the battery is highly dependent on ambient temperature (and consequently on base temperature). If the maximum ambient temperatures (as recorded and displayed in menu: Information -> Fixture Temperatures -> Ambient Temperature -> Maximum NonRes.) are kept within the specified limits, the battery should last for at least two years. Should the ambient temperatures exceed the specified maximum temperature, the lifetime of the batteries could be considerably shortened even up to just one year or less and also result in physical damage (battery leakage) or unreliable fixture functions.

Damage caused by batteries failed due to exceeded maximum ambient temperature cannot be claimed under warranty terms.

Press the [ENTER/Display On] button to display the initial screen with current DMX address:

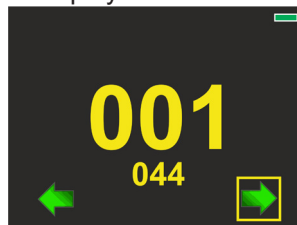

Press the [ENTER/Display On] button to enter the "Address" menu.

An item may be selected from a screen by pressing the [NEXT] or [PREV] buttons to scroll through list items.

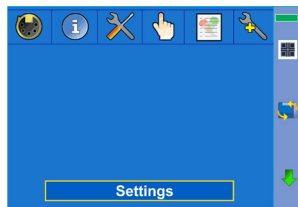

Icon for QR codes
Use [NEXT], [PREV]
buttons for moving
between QR codes

QR code for RDM UID of
the fixture.



QR code for serial number
of LED engine in the fixture.



(pictures for illustration only)

Before first fixture operation, set current date and time in the menu "Date & Time Settings" (menu path: Personality--> Date & Time Settings).

As the fixture can be operated at wide range of ambient temperatures, suitable environment has to be maintained inside of the fixture. The following messages under DMX address inform you about fixture status.



The fixture is waiting for finishing all reset procedures.
Fixture does not respond to DMX.



The fixture is waiting for reaching operating temperature of the fixture
inside (inside temperature is below 0°C).
Fixture does not respond to DMX.



The fixture is in standby mode. Fixture effects does not respond to DMX, but display is active. Fixture sends its statuses and recorded physical values (temperature, humidity, pressure) to the REAP.

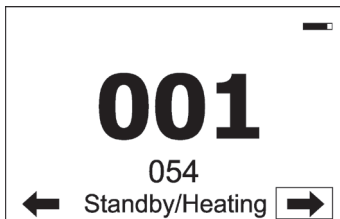

The fixture is in standby mode and inside of the fixture is heated (ambient temperature is below 0°C). Fixture does not respond to DMX, but display is active. Fixture sends its statuses and recorded physical values (temperature, humidity, pressure) to the REAP.

Locking/unlocking the screen.

To lock the screen, display the screen with ROBE logo, touch the [ESCAPE] button and slide your finger clockwise in a circular track of 360° across buttons [ESCAPE] --> [NEXT] --> [ENTER/Display On] --> [PREV]--> [ESCAPE]. The sign "Buttons are locked" will appear on the screen. If this sign will not appear, repeat finger sliding again with a different speed.



To unlock the screen, touch the [ESCAPE] button and slide your finger clockwise in a circular track of 360° across buttons [ESCAPE] --> [NEXT] --> [ENTER/Display On] --> [PREV]--> [ESCAPE]. The sign "Buttons are locked" will disappear from the screen. If this sign still remains on the screen, repeat finger sliding again with a different speed.

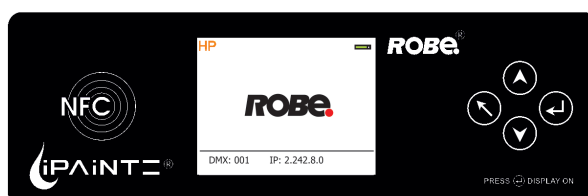

9.1 Tab " Address"



DMX Address - Select the menu to set the DMX start address.

Blinking DMX address means that the fixture is either not receiving DMX data or that the set DMX address is higher than allowed, exceeding the DMX footprint of the set DMX mode.

DMX Presets - The menu item allows you to choose desired DMX mode.

Ethernet Settings - The menu allows all needed settings for the Ethernet operation

Ethernet Mode

Disable - The option disables Ethernet operation.

Artnet - Fixture receives Artnet protocol

gMAI - Fixture receives MANet 1 protocol

gMA2 - Fixture receives MANet 2 protocol

sACN - Fixture receives sACN protocol

Ethernet To DMX - Fixture receives protocol from the Ethernet input and sends DMX data to its DMX output (fixture works as an "Ethernet/DMX converter", next fixture can be connected to its DMX output and you can build a standard DMX chain by connecting another fixtures. Only one fixture has to be connected to the Ethernet.

IP Address/Net Mask - Select this menu to set IP address. IP address is the Internet protocol address. The IP uniquely identifies any node (fixture) on a network.

There cannot be 2 fixtures with the same IP address on the network!

Default IP Address -Preset IP address, you can set up only first byte of IP address (2 or 10) e.g. **002.019.052.086**.

Custom IP Address - The option enables to set up all bytes of IP address.

Net Mask - The option enables to set up all bytes of Net Mask.

ArtNet Universe - Use this item to set a Universe (0-255). The Universe is a single DMX 512 frame of 512 channels.

MANet Settings - Use this menu to set parameters for MANet operation.

MANet Universe I/II - The value of this item can be set in range 1-256.

MANet Session ID - The value of this item can be set in range 1-32.

sACN Settings - Use this menu to set parameters for sACN operation.

sACN Universe - The value of this item can be set in range 1-32000.

Ethernet as Backup - If the function is Enabled, the fixture automatically switches to the Ethernet input for signal receiving in case of DMX signal loss. Correct protocol has to be set in the menu " Ethernet Mode".

9.2 Tab "Information"



Fixture Times - The menu provides readouts of fixture and LED module operation hours.

Power On Time - Select this menu to read the number of fixture operation hours.

Total Hours - The item shows the total number of the operation hours since the Robin iPainte has been fabricated.

Resettable Hours - The item shows the number of the operation hours that the Robin iPainte has been powered on since the counter was last reset.

In order to reset this counter to 0, touch the text box next to the item "Resettable Hours:"

Fixture Temperatures - The menu is used to view temperatures of the fixture's inside.

LEDs temperature - The menu shows temperature on the LED PCB in the light source.

Current - A current temperature of the LED PCB.

Maximum NonRes. - A maximum temperature of the LED PCB since the fixture has been fabricated.

Maximum Res. - A maximum temperature of the LED PCBs since the counter was last reset.

In order to reset some counter to 0, touch desired text box under item "Max.Res."

Driver Temperature - The menu shows temperature on the LEDs control PCB in the fixture head.

Current - A current temperature on the LEDs control PCB.

Maximum NonRes. - A maximum temperature on the LEDs control PCB since the fixture has been fabricated.

Maximum Res. - A maximum temperature on the LEDs control PCB since the counter was last reset.

In order to reset this counter to 0, touch the text box next to the item "Maximum Res."

Base Temperature - The menu shows temperature on the display PCB in the fixture base.

Current - A current temperature on the display PCB.

Maximum NonRes. - A maximum temperature on the display PCB since the fixture has been fabricated.

Maximum Res. - A maximum temperature on the display PCB since the counter was last reset.

In order to reset this counter to 0, touch the text box next to the item "Maximum Res."

RAINS Status - The menu item gives you information about environment in the fixture.

RAINS (Robe Automatic Ingress Neutralization System) manages humidity, temperature and pressure control using an active monitoring system to automatically remove any moisture detected within the fixture and provides permanent monitoring to ensure peak performance of the fixture.

Silica gel desiccants
in the fixture arm

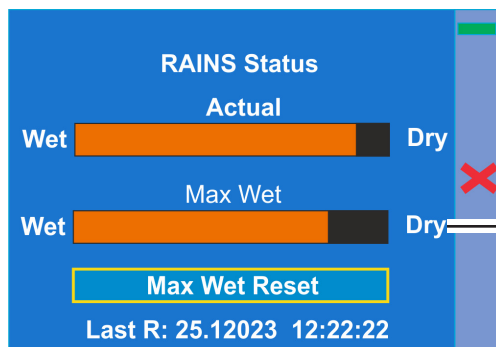

The bar chart **Actual** informs you about current humidity in the fixture. The bar chart changes depending on humidity, temperature and pressure in the fixture. The bar chart depends on current conditions in the fixture and can be different at start of fixture operation, after 10 minutes of its operating, after closing fixture dimmer etc.

The bar chart **MAX WET** informs you about maximum humidity achieved in the fixture since the chart was last reset. The bar chart also informs you about saturation of silica gel desiccants in the fixture arm with water and is deciding indicator for their checking and replacement.

The option **MAX WET reset** resets the bar chart MAX WET. Date and time of last reset is displayed below the option.

Examples of RAINS statuses:

Dry desiccants in the fixture arm

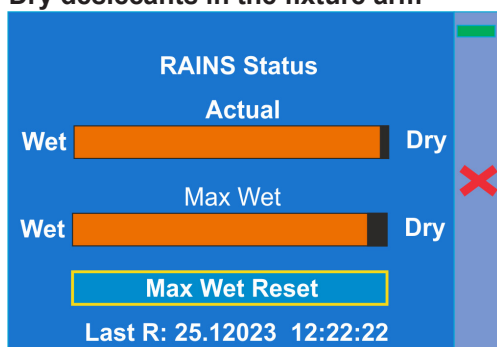

Desiccants in the fixture arm partially saturated with water

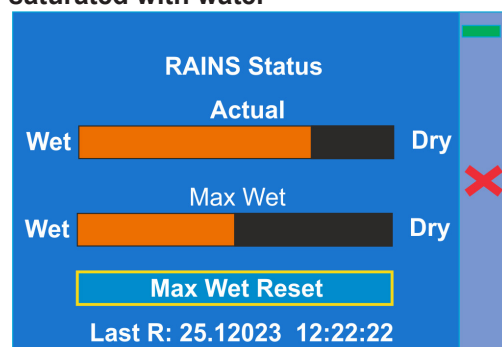

Desiccants in the fixture arm fully saturated with water

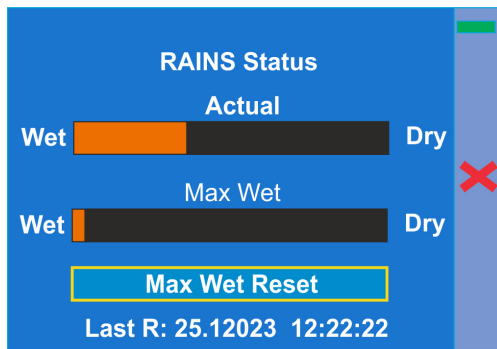

Silica gel desiccants in the fixture arm are saturated with water and should be replaced.

After replacing them, reset the item MAX WET.

It is not necessary to replace silica gels desiccants in plastic boxes in the fixture head and base. These desiccants should be checked (and replaced if it is needed) at removing head or base covers, e.g. at gobo replacement or some service intervention.

Sensors Info - The menu items shows you current conditions in the fixture head (at pressure sensor): temperature, relative humidity and pressure.

DMX Values - The menu items allows you to read DMX values of each channel received by the fixture.

Wireless State - The menu serves for reading of the wireless operation status.

Unlink Wireless Adaptor - The item serves for unlinking the fixture from a DMX transmitter.

If the wireless module is not installed in the fixture, message "Wireless Module Not Installed" will appear.

Power Channel State - Select this item to see current setting of the functions, which can be set by menu items in "Personality" as well as by DMX command at channel "Power/Special functions".

Software Version - Select this item to read the software version of the fixture processors:

Display System - A display processor on the display board in the fixture base

Module M - a Pan/Tilt processor

Module L - a LEDs control processor

Module C - a Colour wheel control processor

Module G - a Gobo wheels control processor

Module F-A - a Framing shutters control processor A

Module F-B - a Framing shutters/Iris control processor B

Module O - a Focus/Zoom/Light frost control processor

Module P - a Prisms/frost control processor

Module DL - a Data Logger control module

Wireless - a Wireless DMX module

Product IDs - The menu is used to read the MAC Address ,RDM UID and RDM Label.

LED Module Info - Use this menu to read LEDs module information.

First Module Assembly - Use the item to read initial information about the LEDs module installed in the fixture. The fixture has to be connected to mains to read the values in the menu items.

Serial Number/ Device UID - a serial number of the LEDs module/RDM UID of the fixture.

Installation Date/Time - a date/time of the first installation of the LEDs module to a some iPainte device.

Intensity - an original intensity of the LEDs module in percentages (100%).

LEDs On Time Total/Adaptive - Total: a total time of the LEDs module operation during which the dimmer intensity was > 0%.

Adaptive: a relative time of the LEDs module operation during which the dimmer intensity was > 0% (e.g. if dimmer = 50% for one hour, the adaptive time is 0.5 hour, if dimmer = 100% for one hour, the adaptive time is 1 hour).

Actual Module Info - Use the item to read current information about the LEDs module installed in the fixture.

Serial Number/ Device UID - a serial number of the LEDs module/RDM UID of the fixture.

Measurement Date/Time - a date/time of running the procedure "LEDs Measure" in the tab Service.

Intensity - the item shows a light intensity of the LEDs module measured after running the procedure "LEDs Measure" in the tab Service. The light intensity is displayed in percentages in relation to the initial intensity of the new LEDs module (initial intensity=100%).

LEDs On Time Total/Adaptive - Total: a total time of the LEDs module operation during which the dimmer intensity was > 0%.

Adaptive: a relative time of the LEDs module operation during which the dimmer intensity was > 0% (e.g. if dimmer = 50% for one hour, the adaptive time is 0.5 hour, if dimmer = 100% for one hour, the adaptive time is 1 hour).

Assembly History - Use the item to read a history of the LEDs module installed in the fixture (its serial number, RDM UID of fixture at which was installed and date/time of installation).

Up to 31 records can be saved in the menu item.

Intensity History - Use the item to read a history of light intensity of the LEDs module installed in the fixture.

Serial Number/ Device UID - a serial number of the LEDs module/RDM UID of the fixture.

Measurement Date/Time - a date/time of running the procedure "LEDs Measure" in the tab Service.

Intensity - the item shows a light intensity of the LEDs module measured after running the procedure "LEDs Measure" in the tab Service. The light intensity is displayed in percentages in relation to the initial intensity of the new LEDs module (initial intensity=100%) .

Up to 31 records can be saved in the menu item.

LED Module History - Use the item to read a history of the LEDs modules installed in the fixture (their serial numbers and date/time of installation).

Up to 31 records can be saved in the menu item.

View Logs - Use this menu to read fixture's data which have been recorded during fixture operation. This collected data allows easier troubleshooting.

Fixture Errors - Use this menu to read fixture errors which have occurred during fixture operation.

Fixture States - In the menu are recorded fixture states as power on and power off.

Fixture Positions - In the menu are recorded installation positions of the fixture:

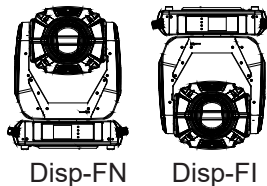

Fixture Temperatures - In the menu are recorded temperatures which have exceeded defined levels.

Sensor Logs - In the menu item are recorded physical values in the fixture: temperature, relative humidity and pressure.

Pressure Test Log - In the menu item are recorded values related to executed pressure tests: date and time, temperature, pressure difference, duration of pressure test and its result.

Note: The log buffer can contain max. 8000 records. If the buffer is full, old data will be overwritten.

9.3 Tab "Personality"



User mode - The Robin iPainte allows you to recall two user settings. After switching the fixture on for the first time, the User A settings is active. Now all changes made in the "Personality" menu , "Addressing" menu and the "Music Trigger" and "Preset Playback" items from the "Stand-alone" menu are saved to the User A settings. If you now select the User B settings, from this moment the changes made in these menus will be saved to the User B settings. After switching the fixture off and on, the User B setting is active. In this way you may use the two fixture operating behaviours.

User A Settings - the function recalls the user A settings.

User B Settings - the function recalls the user B settings.

DMX Preset - Use the menu to select desired channel mode.

Mode 1 - 44 control channels

Mode 2 - 45 control channels

View Selected Preset - Use the menu to display channels included in the selected mode.

DMX Input- Use the menu to select mode of DMX signal receiving.

Wired - DMX signal is received by means of the standard DMX cable.

Wireless - DMX signal is received by means of the inbuilt wireless module.

Wireless In/XLR Out- the fixture receives wireless DMX and sends the signal to its wired DMX output.

The fixture behaves as " Wireless/Wired" adapter.

The options "Wired" and "Wireless" are also stated in DMX chart (channel Power/Special functions).

Note. If the wireless module is not installed in the fixture, the following message will appear:

DMX Input Set to Wired

Wireless Module Missing

If the fixture is not connected to mains, the message "Not Available In Offline Mode" will appear after entering the menu DMX Input. To enter this menu, the fixture has to be connected to mains.

Pan/Tilt Settings - Use the menu set behaviour of both pan and tilt movements.

Pan Reverse - The item allows to invert pan movement.

Tilt Reverse - The item allows to invert tilt movement.

Pan/Tilt Feedback - The item allows to return the moving head to the required pan/tilt position after changing the position by an external force if this option is set on.

Note. Be careful, the Pan/Tilt Feedback should be permanent On, the option Off is not suitable for standard operation and the head of the fixture can be damaged!

Pan/Tilt mode - Use this menu to set the mode of the pan/tilt movement

Time mode – The pan and tilt will move with different speeds and they will come at the same time to the end point of their tracks (pan and tilt use their optimal speeds).

Time of the pan/tilt movement (25.5 sec. max.) is set by the channel "Pan/Tilt speed, Pan/Tilt time".

Speed Mode - Both Pan and tilt will move with the same speed as adjusted at the channel "Pan/Tilt speed, Pan/Tilt time".

Pan/Tilt EMS - Built-in electronic motion stabilizer ensures precise position of the fixture's head during its movement and also reducing its swinging when the truss shakes.

Pan/Tilt Limitations - The function allows you to reduce range of pan and tilt movement by setting limits for both movements.

Pan Min. Value - Minimum pan movement value.

Pan Max. Value - Maximum pan movement value.

Tilt Min. Value - Minimum tilt movement value.

Tilt Max. Value - Maximum pan movement value.

If receiving DMX values are out of set limits, the fixture will not respond to them.

Example: Pan Min. Value=40 DMX, Pan Max. Value=120 DMX, the head will move in pan range of 40-120 DMX. Values under 40 and above 120 will not be used.

At reset of the head without connected DMX (if Pan/Tilt brake=Off), the pan movement of the head will stop in the value 120 DMX. After cancelling the pan movement limitation, the head will move to the value 128 DMX . (Standard pan and tilt positions after reset of the head without DMX are 128 DMX, unless otherwise set in the menu Init Positions).

Blackout Settings - Use the menu if you need to close the light output under certain conditions which are described below

Blackout During MC - Blackout during movement correction. Set this option On if you wish to close light output during the time when the head goes to its correct position from which has been changed by an external force.

Active Blackouts - Use this menu if you wish to close the light output during effect changes.

Pan/Tilt Moving - The menu item enables you to close light output while the pan/tilt DMX values are changing.

Colour Wheel Moving - The menu item enables you to close light output while colour wheel is moving.

Frequency Setup - The function allows you to set the PWM (Pulse Width Modulation) output frequency of LEDs to 300Hz, 600Hz, 1200Hz or 2400Hz.

Frequency Adjust - The menu item allows you fine adjustment of the LED frequency around selected frequency.

Init Effect Positions - Use the menu to set all effects to the desired positions at which they will stay after switching the fixture on without DMX signal received.

Screen Settings - Use this menu to change the touch screen settings.

Display Intensity - The item allows to control the intensity of the screen (1-min., 10-max.).

Screen saver Delay - The item allows you to keep the screen on or to turn it off automatically after 1-10 minutes after last touch (or pressing any button on the control panel).

Touchscreen Lock - The item allows you to lock the screen after last touch (or pressing any button on the control panel). The time delay can be set in range of 1-10 minutes. To unlock the screen, press the [ENTER/Display On] button.

Recalibrate Touchscreen - The item starts calibration of the touch screen. Follow the instructions on the screen.

Display Orientation - The menu allows to change display orientation.

Normal - Standard display orientation if the fixture is placed horizontally (e.g. on the ground).

Inverted - Inverted orientation (needed if the fixture is hanging on the truss).

Auto - The option activates a gravitation sensor for automatic screen orientation.

Note: **Auto** option is set as default. You change the display orientation by touching the icon  on the display, and the option set in the "Display Orientation" menu is temporarily overridden.

Temperature unit - Use the menu item to change temperature unit from °C to °F.

Fan Settings - Use the menu to set fans operation mode.

Fan Mode - Use the menu to set the fixture fans to max. power mode (option "**High**") or to the auto-control mode (option "**Auto**"). The third option "**Quiet**" allows you to set desired fan noise. The light output of the fixture is reduced at low speeds of fans.

Quiet - Blackout Fan Off - The menu item allows you to stop all fans in the fixture (option "**On**") when its light output is closed (shutter in range of 0-31 DMX or dimmer in 0 DMX).

Dimmer Curve - Use the menu to select desired dimmer curve: **Linear**, **Square Law** or **Super Square Law**.

Gobo Indexing - The following three options define transition from gobo rotation to gobo indexing.

Max. Speed & Shortcut - Gobo goes from its rotation to desired indexed position with max. speed and via shortest track.

Follow Speed & Direction - Gobo goes from its rotation to desired indexed position with current speed and keeps a direction of rotation.

Max. Speed & Follow Dir. - Gobo goes from its rotation to desired indexed position with max. speed and keeps a direction of rotation.

Date & Time Settings - Use this menu to set current date and time for the fixture log system (menu "View Logs"). Set this menu items before first fixture operation.

Focus Tracking - This feature provides automatic sharpness re-adjustment during zoom movement, after an initial sharpness has been set by the operator by setting the focus channel and enabling the FocusTracking. The Focus Tracking feature is done via automatic movement of focus element, taking into account several internal parameters, zoom position being one of them. To utilize the Focus Tracking, make sure to enable the Focus Tracking, set the Zoom to value 200 and adjust Focus to desired sharpness. Then, while keeping Focus value untouched, you can move the Zoom. Fixture will automatically keep the projection at the desired sharpness as much as possible. You can also re-adjust the Focus value over time if needed. When switching between Rot.

gobo wheel, Static gobo wheel and an empty aperture, the Tracking Focus will adjust the internal parameters, therefore providing desired sharpness by adjusting the Focus might be required. If you use both Rot. gobo wheel and Static gobo wheel without further adjusting the Focus value, Static gobo wheel will be automatically used for Focus Tracking 's focusing.

Default Settings - The menu item allows to set all fixture parameters in this menu to the default (factory) values except items "DMX Input".

Password Protection - allows to enter password in order to prevent unauthorized person from changing setting of the fixture. Password is set to 7623 and cannot be changed.

Reset Web Password - The menu item allows you to reset a password for access to the REAP (default password: 2479, user: robe).

9.4 Tab "Manual Control"



Reset Functions - The menu allows to reset the fixture either per function modules or all modules together.

Total System Reset - The item resets all function modules.

Pan/Tilt Reset - The item resets a pan and a tilt.

Colour System Reset - The item resets colour wheel and CMY+CTO system.

Gobos Reset - The item resets rotating gobo wheels.

Optics/Prism/Frost Res. - The item resets a zoom, focus, prism and a frost module.

Iris/Framing Sh. Reset - The item resets an iris module and framing shutters.

Manual Effect control - Use the menu to control all fixture channels by means of the control panel.

9.5 Tab "Stand-alone"



Test Sequences - Use the menu to run a test/demo sequences without an external controller, which will show you some possibilities of using Robin iPainte.

Dynamic Mode - This mode uses all Robin iPainte functions including pan/tilt movement and therefore is good for a complete introduction of the fixture.

Static Mode - This mode is suitable for projections on the wall, ceiling or ground without any pan/tilt movement. Adjust the pan, tilt, zoom and focus to desired positions and start test sequences by touching the green ► icon.

Preset Playback - This menu allows you to select the program which will be played in a loop after switching the fixture on (the option is commonly used in a stand-alone operation without an external controller).

None - The option disables "Presetting playback" function.

Test - The option starts the test sequences.

Prog. 1 - The option starts user program No. 1.

Prog. 2 - The option starts user program No. 2.

Play program - Use the menu to run desired program in a loop.

Play Program 1 - The option starts user program No. 1.

Play Program 2 - The option starts user program No. 2.

Edit Program - Use the menu to create or to edit desired program. The Robin iPainte offers 2 free programs, each up to 80 steps.





Edit Program 1 - The option allows you to edit user program No.1.

Edit Program 2 - The option allows you to edit user program No.2.

To edit program:

1. Touch the item which you want to edit ("Edit Program 1" - "Edit Program 2").
 2. Touch the item "Edit Program Steps".
 3. Touch the item "Step 1".
 4. From the list of effects touch desired effect and set its value. Browse through the list by touching the [up arrow] and [down arrow] and set all desired effects.
- An item "Step Time" (value of 0-25.5 sec.) is the time during which effects last in the current step
5. Save adjusted effects to the current step by touching the [confirm] or save and copy them to the following step by touching the [confirm+copy]. By touching the text box "Preview" next to the current program step you can view created scene.
 6. Repeat the steps 4 and 5 for next program steps.
 7. After editing desired program steps, adjust the length of the program by touching the text boxes "Start Step" and "End Step".

Meaning of the icons used in the "Edit Program" menu:

-  - moves down on the next page
-  - moves up on the previous page
-  - saves adjusted values and leaves menu
-  - saves values to the current step and copy them to the following prog. step
-  - leaves menu without saving values

9.6 Tab "Service"



Pressure Test - The menu item runs a procedure which checks the IP65 integrity of the fixture. The fixture has to be connected to mains and the head temperature (at pressure sensor) cannot be higher than 55°C. The pressure test lasts about 10 minutes and can be run at earliest 8 minutes after closing light output (shutter closed) of the fixture. The pressure test can be repeated at earliest 2 minutes after last pressure test.
For more details of pressure test please see the chapter Checking the IP65 integrity of the fixture.

Adjust DMX Values - The menu allows you to set all effects to desired positions before fine calibration of the effects .

Calibrations - This menu enables fine calibration of fixture effects and download default calibration values.

Calibrate Effects - The menu allows the fine adjustment of effects.

Pan- a pan position fine adjustment (value range: 0-255)

Tilt - a tilt position fine adjustment (value range: 0-255)

Rot. Gobo Wheel - a carousel of rotating gobos fine movement (value range: 0-255)

R. Gobo Index 1 - a fine movement of the rotating gobo 1 (value range: 0-255)

R. Gobo Index 2 - a fine movement of the rotating gobo 2 (value range: 0-255)

R. Gobo Index 3 - a fine movement of the rotating gobo 3 (value range: 0-255)

R. Gobo Index 4 - a fine movement of the rotating gobo 4 (value range: 0-255)

R. Gobo Index 5 - a fine movement of the rotating gobo 5 (value range: 0-255)

R. Gobo Index 6 - a fine movement of the rotating gobo 6 (value range: 0-255)

R. Gobo Index 7 - a fine movement of the rotating gobo 7 (value range: 0-255)

R. Gobo Index 8 - a fine movement of the rotating gobo 8 (value range: 0-255)

Static Gobo - a static gobo wheel fine movement (value range: 0-255)

Colour Wheel - a colour wheel fine movement (value range: 0-255)

Cyan - a cyan flag fine movement (value range: 0-255)

Magenta - a magenta flag fine movement (value range: 0-255)

Yellow - an yellow flag fine movement (value range: 0-255)

Prism 1 - a prism fine movement in relation to stop (value range: 0-255)

Prism 2 - a prism fine movement in relation to optic axis (value range: 0-255)

Prism Rotation - a prism fine rotation (value range: 0-255)

Zoom - a zoom module fine movement (value range: 0-255)

Focus - a focus module fine movement (value range: 0-255)

Iris - an iris fine movement (value range: 0-255)

Frost 1 - a frost fine movement in relation to stop (value range: 0-255)

Frost 2 - a frost fine position movement in relation to optic axis (value range: 0-255)

Fr. Shutters. rot- a framing shutters module fine rotation (value range: 0-255)

Fr. Shutter 1 Move - a Fram. lamella 1 fine moving

Fr. Shutter 1 Swiv. - a Fram. lamella 1 fine swivelling

- Fr. Shutter 2 Move** - a Fram. lamella 2 fine moving
- Fr. Shutter 2 Swiv.**- a Fram. lamella 2 fine swivelling
- Fr. Shutter 3 Move** - a Fram. lamella 3 fine moving
- Fr. Shutter 3 Swiv.** - a Fram. lamella 3 fine swivelling
- Fr. Shutter 4 Move** - a Fram. lamella 4 fine moving
- Fr. Shutter 4 Swiv.** - a Fram. lamella 4 fine swivelling lling

Calibration of the effects via the control board

1. Disconnect DMX controller from the fixture and enter the "Calibrate Effects" menu.
2. Use the [up arrow] and [down arrow] to find "Pan" and touch it to enter the fine effect adjustment screen.
3. Set desired value and save it by touching the [confirm].
4. Repeat steps 2 and 3 for next item
5. After calibrating all effects, touch the [confirm] to save all adjusted values and reset the fixture.

Calibration protocol:

Effect	Mode 1	Mode 2
Pan	channel 45	channel 46
Tilt	channel 46	channel 47
Rot. Gobo Wheel	channel 47	channel 48
R. Gobo Index 1	channel 48	channel 49
R. Gobo Index 2	channel 49	channel 50
R. Gobo Index 3	channel 50	channel 51
R. Gobo Index 4	channel 51	channel 52
R. Gobo Index 5	channel 52	channel 53
R. Gobo Index 6	channel 53	channel 54
R. Gobo Index 7	channel 54	channel 55
R. Gobo Index 8	channel 55	channel 56
Static gobo	channel 56	channel 57
Colour wheel	channel 57	channel 58
Cyan	channel 58	channel 59
Magenta	channel 59	channel 60
Yellow	channel 60	channel 61
Prism 1	channel 61	channel 62
Prism 2	channel 62	channel 63
Zoom	channel 63	channel 64
Focus	channel 64	channel 65
Iris	channel 65	channel 66
Frost 1	channel 66	channel 67
Frost 2	channel 67	channel 68
Fr. Shutters rot.	channel 68	channel 69
Fr. Shutter 1 Move	channel 69	channel 70
Fr. Shutter 1 swiveling.	channel 70	channel 71
Fr. Shutter 2 Move	channel 71	channel 72
Fr. Shutter 2 swiveling	channel 72	channel 73
Fr. Shutter 3 Move	channel 73	channel 74
Fr. Shutter 3 swiveling	channel 74	channel 75
Fr. Shutter 4 Move	channel 75	channel 76
Fr. Shutter 4 swiveling	channel 76	channel 77

Calibrate Fr. Hysteresis

Framing Lamella 1 - a framing lamella 1 reverse movement (value range: 0-8)

Framing Lamella 2 - a framing lamella 2 reverse movement (value range: 0-8)

Framing Lamella 3 - a framing lamella 3 reverse movement (value range: 0-8)

Framing Lamella 4 - a framing lamella 4 reverse movement (value range: 0-8)

The value set for every framing lamella gives a value at which the lamella reacts to its reverse movement promptly (without movement hysteresis).

Calibrate CMY Offsets - The menu item allows you to set a course of colour intensity for cyan, magenta and yellow flag

Calibrate Pan/Tilt EMS - The menu item allows you calibration of the pan/tilt electronic motion stabilizer. Important: during this calibration any external force must not influence the fixture and the surface at which the fixture stands (or truss if the fixture hangs) has to be without movement, shake, strokes etc.

Calibrate Pan/Tilt Reset - The menu item is used for calibration of pan/tilt reset in factory and also has to be used in case of changing of pan or tilt motor or pan/tilt control PCB (RB3138 in the fixture yoke).

Load Default Calibrations - The item loads default (factory) calibration values.

Rotating Gobos Change - This menu makes changing of rotating gobos in the fixture easier.

Gobo Carousel - The menu allows movement of rotating gobos on the gobo carousel to position suitable for their changing.

G1-Mg - a movement of the gobo 1 (gobo holder with magnet) to the changing position.

G2 - a movement of the gobo 2 to the changing position.

:

Gobo Offset - a gobo offset setting. The function allows fine swivelling of the gobo holder. The set value is valid for all gobos on the gobo carousel 1.

LEDs Measure - This menu item runs a procedure which measures a light intensity of the LEDs module installed in the fixture. This procedure takes about 1 minute (message "LEDs Module Measurement" is displayed on the screen). During the procedure the fixture does not receive DMX signal, pan/tilt go to 128 DMX, a shutter is open and a dimmer is set at max. light intensity (255 DMX). All effects are taken out from the light beam. The measured light intensity is recorded in the item Intensity in the menu LED Module Info:

Tab Information --> Actual Module Info --> Intensity

Tab Information --> Intensity History --> Intensity

The light intensity in the menu item Intensity is displayed in percentages in relation to the initial intensity of the new LEDs module (initial intensity=100%).

The LEDs Measure procedure should be run after every change of the LED light source.

Note: The fixture has to be connected to mains in order to run LEDs Measure procedure.

Update software - The menu item allows you to update software in the fixture.

The following items are required in order to update software:

- PC running Windows or Linux or macOS
- DSU file
- Flash cable RS232/DMX, P/N13050624 (if you want to use a serial port of PC)
- Robe Universal Interface or Robe Universal interface WTX (if you want to use an USB port of PC)

After the software updating the fixture will be set to default values.

To update software in the fixture:

1. DSU file is available from Robe web site at WWW.robe.cz.
File with extension zip is intended for Windows (used and tested from XP to W11 on 32/64bit systems).
File with extension tbz is intended for Linux (used and tested on Debian and Ubuntu 32/64bit).
File with extension dmg is intended for macOS (used and tested on OSX up to Sierra) XQuartz required, install it from <https://www.xquartz.org/>
Save the download file to a folder on your computer.
In case that you use windows, extract files in the zip file (e.g. DSU_RobiniPainte_18100828.zip)
2. Disconnect the fixture from DMX controller.
3. If you use the flash cable RS232/DMX, connect a serial port of your computer with DMX input of the fixture by means of the cable.
If you use the Robe Universal Interface, connect a USB port of your computer with the Robe Universal Interface by means of the USB cable and DMX input of the fixture with the DMX output of the Robe Universal Interface via a DMX cable.
4. Switch the fixture to the update mode (tab "Service" --> Update Software).
Note: If you do not want to continue in the software update, you have to switch off and on the fixture to escape from the updating mode.
We recommend to cancel all running programs on your computer before starting the software update.
5. Double-click the software uploader file (e.g. DSU_RobiniPainte_18100828.exe) in the extracted files. The Software Uploader program will start to run.

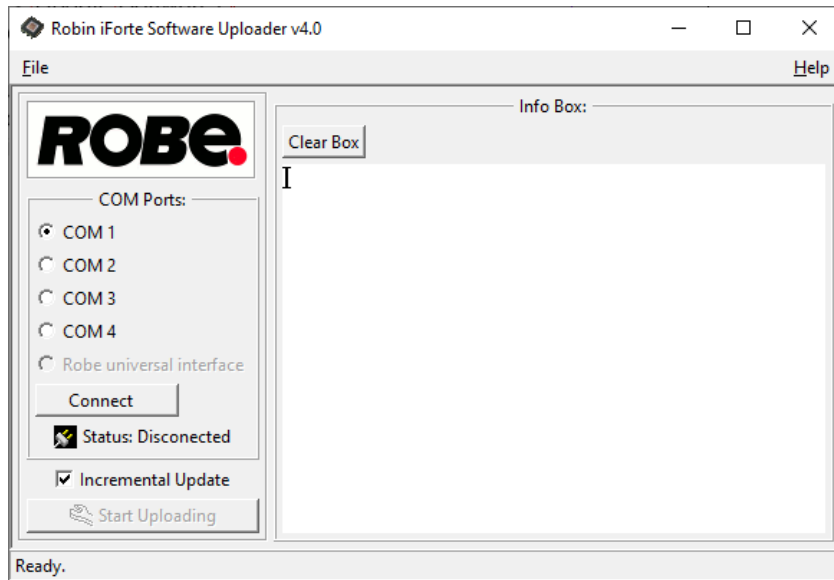

6. Select correct "COM " number if you use a Flash cable RS232/DMX or select "Robe Universal Interface " if you use the Robe Universal Interface/Robe Universal Interface WTX and then click on the "Connect" button.
7. If the connection is OK, click the "Start Uploading" button to start software uploading. It will take several minutes to perform software update.
 If the option "Incremental Update" is not checked, all processors will be updated (including processors with the same software version).
 If you wish to update only processors with new version of software, check the "Incremental Update box".
 Avoid interrupting the process. Update status is being displayed in the "Info Box" window.
 When the update is finished, the line with the text "Fixture is successfully updated" will appear in this window.
 In case upload process is interrupted (e.g. power loss), the fixture stays in "Updating mode" and you will have to repeat the software update again.

Another way, how to update software in the fixtures (especially large installation of fixtures) is to use the ROBE Uploader. It is a software for automatized software update of Robe fixtures. It takes advantage of RDM support).

For more information please see <https://www.robe.cz/robe-uploader/>.

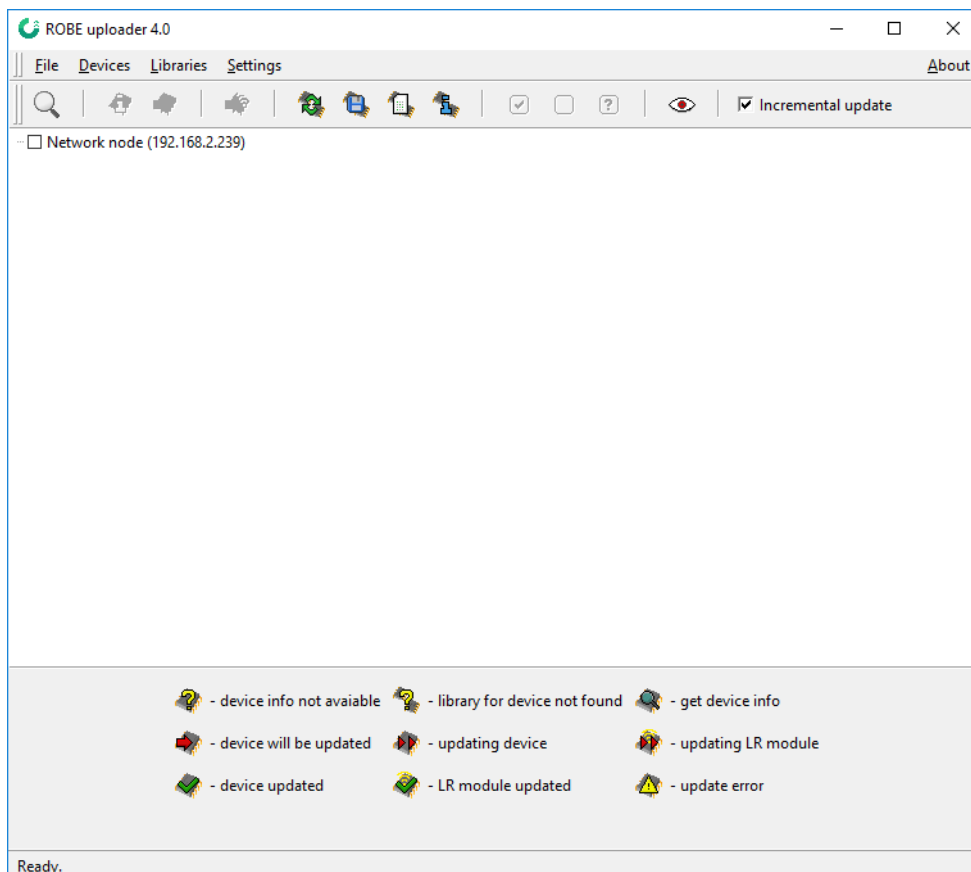

10. RDM

This fixture supports RDM operation. RDM (Remote Device Management) is a bi-directional communications protocol for use in DMX512 control systems, it is the new open standard for DMX512 device configuration and status monitoring.

The RDM protocol allows data packets to be inserted into a DMX512 data stream without adversely affecting existing non-RDM equipment. By using a special „Start Code,“ and by complying with the timing specifications for DMX512, the RDM protocol allows a console or dedicated RDM controller to send commands to and receive messages from specific moving lights.

RDM allows explicit commands to be sent to a device and responses to be received from it.

The list of commands for Robin iPainte is the following:

Parameter ID	Discovery command	SET command	GET command
DISC_UNIQUE_BRANCH	*		
DISC_MUTE	*		
DISC_UN_MUTE	*		
DEVICE_INFO			*
SUPPORTED_PARAMETERS			*
SOFTWARE_VERSION_LABEL			*
DMX_START_ADDRESS		*	*
IDENTIFY_DEVICE		*	*
DEVICE_MODEL_DESCRIPTION			*
MANUFACTURER_LABEL			*
DEVICE_LABEL		*	*
SENSOR_DEFINITION			*
SENSOR_VALUE			*
DISPLAY_INVERT		*	*
DISPLAY_LEVEL		*	*
PAN_INVERT		*	*
TILT_INVERT		*	*
DEVICE_RESET		*	
DMX_PERSONALITY		*	*
DMX_PERSONALITY_DESCRIPTION			*
STATUS_MESSAGES			*
STATUS_ID_DESCRIPTION			*

RDM model ID for the Robin iPainte is 0x0135.

If you need to set RDMnet scope, use the ROBE Ethernet Acces Portal (REAP) and menu Personality-->-->Ethernet Settings.

The screenshot shows the 'Ethernet settings' window for the 'iPainte' fixture. It includes the following fields and options:

- Ethernet mode:** Radio buttons for 'disable' (selected), 'ArtNet', 'gMA1', 'gMA2', and 'sACN'.
- Ethernet to DMX:** Radio buttons for 'off' (selected) and 'on'.
- ArtNet universe:** Text input field with value '0'.
- MANet I/II universe:** Text input field with value '1'.
- MANet session ID:** Text input field with value '1'.
- sACN universe:** Text input field with value '1'.
- RDMnet scope:** Text input field with value 'default', highlighted by a red rectangle.
- Save:** A blue button at the bottom right.

11. Error and information messages

Error in the fixture is signalled by the yellow warning icon at the bottom line of the screen:

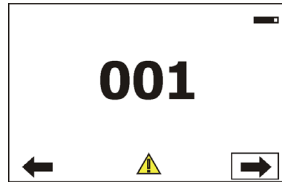

Select the warning icon or press the [ESCAPE] button to display error messages.

List of error and information messages:

Pan Error 1

Mechanical end of the pan track was not detected.

Pan Error 2

Pan sensor error.

Pan Error 3

Pan feedback error.

Tilt Error 1

Mechanical end of the tilt track was not detected.

Tilt Error 2

Tilt sensor error.

Tilt Error 3

Tilt feedback error.

Colour Wheel Error 1

Magnetic/optic sensor was not detected.

Colour Wheel Error 2

Magnetic/optic sensor permanently detects colour wheel.

Prism Rot. Error 1

Magnetic/optic sensor was not detected at prisma wheel.

Prism Rot. Error 2

Magnetic/optic sensor permanently detects prism wheel

Prism Error 1

Impact to the mechanical end of the prism wheel track was not detected.

Prism Error 4

Incorrect detection of a prism wheel track. Impact to a mechanical obstruction was detected within running of the prism .

Iris Error 1

Impact to the mechanical end of the iris track was not detected.

Iris Error 4

Incorrect detection of a iris track. Impact to a mechanical obstruction was detected within running of the iris.

Frost Error 1

Impact to the mechanical end of the frost track was not detected.

Frost Error 4

Incorrect detection of a frost track. Impact to a mechanical obstruction was detected within running of the frost.

Zoom Error 1

Impact to the mechanical end of the zoom track was not detected.

Zoom Error 4

Incorrect detection of a zoom track. Impact to a mechanical obstruction was detected within running of the zoom.

Focus 1 Error 1

Impact to the mechanical end of the focus module track was not detected.

Focus Error 4

Incorrect detection of a focus track. Impact to a mechanical obstruction was detected within running of the focus module.

Gobo Carousel Error 1

Magnetic/optic sensor was not detected.

Gobo Carousel Error 2

Magnetic/optic sensor permanently detects gobo carousel.

Gobo Rotation Error 1

Magnetic/optic sensor was not detected on the rotating gobo on the gobo carousel.

Gobo Rotation Error 2

Magnetic/optic sensor permanently detects rotating gobo on the gobo carousel.

Fr. Shutters Rot. Error 1

Impact to the mechanical end of the framing shutters wheel was not detected.

Fr. Shutters Rot. Error 2

Incorrect detection of the framing shutters wheel. Impact to a mechanical obstruction was detected within running of the framing shutters wheel.

Fr. Shutter 1 Error 1

Impact to the mechanical end of the framing shutter 1 was not detected.

Fr. Shutter 1 Error 4

Incorrect detection of the framing shutter 1. Impact to a mechanical obstruction was detected within running of the framing shutter 1.

Fr. Shutter 2 Error 1

Impact to the mechanical end of the framing shutter 2 was not detected.

Fr. Shutter 2 Error 4

Incorrect detection of the framing shutter 2. Impact to a mechanical obstruction was detected within running of the framing shutter 2.

Fr. Shutter 3 Error 1

Impact to the mechanical end of the framing shutter 3 was not detected.

Fr. Shutter 3 Error 4

Incorrect detection of the framing shutter 3. Impact to a mechanical obstruction was detected within running of the framing shutter 3.

Fr. Shutter 4 Error 1

Impact to the mechanical end of the framing shutter 4 was not detected.

Fr. Shutter 4 Error 4

Incorrect detection of the framing shutter 4. Impact to a mechanical obstruction was detected within running of the framing shutter 4.

EEprom Error

Hardware error of the EEprom.

Recharge The battery

The battery on the display board needs to be charged. Let the fixture on for cca 6 hrs.

Battery Faulty. Replace it.

The battery on the display board is exhausted and should be replaced immediately.

Pan/Tilt EMS Cal. Error

The EMS system is not calibrated.

Pan/Tilt EMS Error

Control electronics cannot communicate with the EMS system.

Internal Error 1

Communication error between PCBs (error or noise was detected on communication wires)

Internal Error 2

Communication error (some PCB has failed or is disconnected (this PCB will show as N/A in menu --> Information --> Software versions) or error/noise was detected on communication wires)

Overheated

The LED engine is overheated and light output is closed.

White 1 Short Error (White 2 Short Error/ White 3 Short Error/ White 4 Short Error)

Some white LEDs in the light source have short circuit or are disconnected.

White 5 Short Error (White 6 Short Error/ White 7 Short Error/ White 8 Short Error)

Some white LEDs in the light source have short circuit or are disconnected.

Suction LED Fan 1 Bad/ Suction LED Fan 2 Bad

The suction fan 1 (fan 2) at the LED engine is disconnected from its control PCB or is faulty and should be replaced.

Base Fan Bad

The fan in the fixture base is disconnected from its control PCB or is faulty and has to be replaced. .

Exhaust LED Fan 1 Bad/ Exhaust LED Fan 2 Bad

The exhaust fan 1 (fan 2) at the LED engine is disconnected from its control PCB or is faulty and should be replaced.

Too Much Humidity in Device

To remove the message, reset the bar chart Max.Wet in the menu RAINS Status (tab Information) and check the silica gel desiccants in the fixture arm.

Valve Seal Error

The valve in fixture arm or coil in the valve is defective or there is a connection problem between the valve and head, check cable connector at valve.

Positions of cooling fans and their control PCBs:

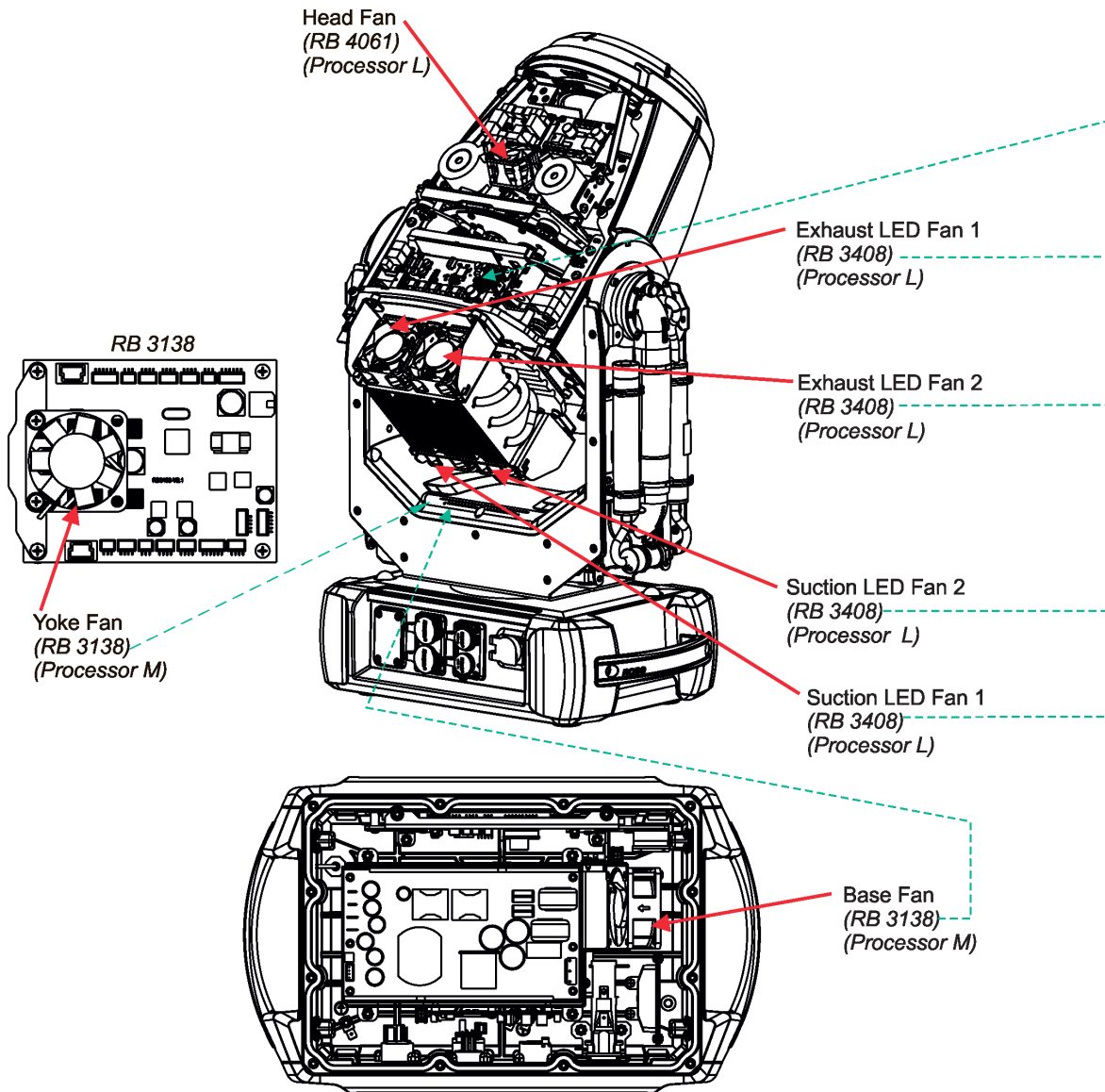

12. NFC

The fixture supports NFC (Near-Field Communication). Using the mobile phone application ROBE COM you can read and set the Robin iPainte parameters (DMX address, IP address...etc.), get information about temperatures, operation hours, RDM identification etc.

The NFC point is situated on the front panel of fixture's base.

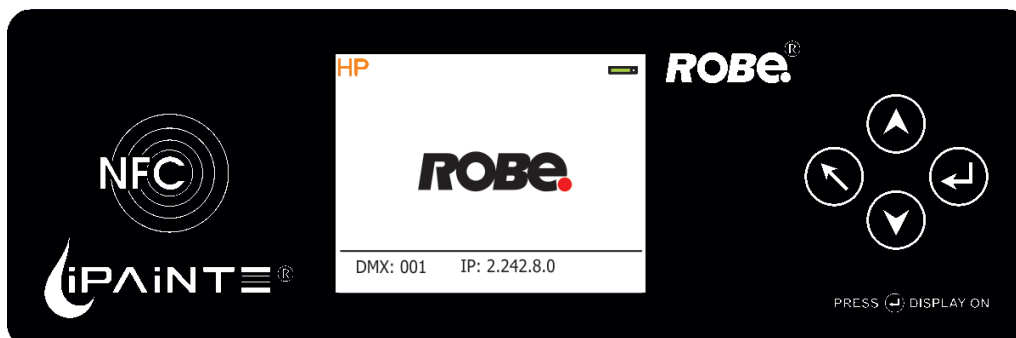

Download and install the ROBE COM from Google Play (for Android 5.0 and higher) or App Store (for iOS 12.0 and higher) to your mobile phone. Your mobile phone has to support NFC.

Hold the mobile phone on the side of the fixture base, if NFC connection is OK, discovered fixture will appear on the screen, after touching the fixture name the following the following menu items will appear:

- DMX/RDM settings
- Ethernet settings
- Blackout settings
- Colour settings
- Display settings
- Standalone settings
- Pan/Tilt settings
- Other settings
- Software versions
- Device hours
- Device temperatures

Touch desired menu item to enter its submenu.

13. Cleaning

DANGER !

Always disconnect the fixture from mains before starting any cleaning work.

Regular cleaning will not only ensure the maximum light output, but will also allow the fixture to function reliably throughout its life.

The frequency of cleaning depends on the environment in which the fixture operates: damp, smoky or particularly dirty environments can cause greater accumulation of dirt on the fixture housing.

The front glass cover of the head will require cleaning on a monthly basis. A soft lint-free cloth dampened with a solution of water and a mild detergent is recommended, under no circumstances should alcohol, solvents or abrasives be used!

Stains caused by hard water (water that has high mineral content) can be effectively removed by means of non - abrasive descaler (e.g. EverStar descaler).

14. Maintenance

Do not do maintenance in a damp environment (e.g. rain, snowfall)!
DANGER !
Always disconnect the fixture from mains before starting any maintenance work.

In order to ensure the fixture remains in good condition and does not fail prematurely, we recommend regular maintenance.

The following points have to be considered during fixture inspection:

- All outside covers and screws should be checked for damages, scratches or corrosion.
- All connectors and its rubber caps should be checked for damages or sediments.
- All screws and fasteners has to be securely tightened. Check for any deformation on the housing and rigging points. Damaged rigging points or unsecured rigging could cause the fixture to fall and seriously injure people.
- Electric power supply cable must not show any damage or material fatigue.
- Fans and heatsink should be checked for sediments or dirt/debris accumulation.

User can do the following operations:

- Gobo replacement
- Frost replacement
- LEDs module replacement
- Silica gel desiccants replacement
- Main fuse replacement
- Battery replacement
- Lubrication of internal parts of the fixture

Another maintenance and service operations should be carried out by trained technician only. If you need any spare parts, please order genuine parts from your local Robe distributor.

In case of problem with smooth running of CMY colour mixing system, lubricate sliding bars of CMY flags. As lubricant we recommend ÅRONIX silicone oil 500 cSt - it is a medium viscosity lubricant, release agent, high temperature oil.

Fixture metal covers are made of material resistant to corrosion, potential damages of covers (like scratches, abrasions) are only appearance defects and will not cause corrosion of covers.

To repair small damages of fixture metal covers (e.g. scratches), you can use a paint intended for non-rusting metal surfaces (like aluminium, copper...). The paint can be applied to surface by means of a small brush or by spraying.

Use the paint with the same colour and sheen as has your cover. The paint can perform as undercoat or top-coat, it doesn't matter.

Do not remove fixture covers in smoky or particularly dirty environment (e.g. with fog machines)

IMPORTANT The fixture head should be uncovered as short time as possible (about 1-2 hours depending on air humidity) otherwise silica gel in small boxes in the fixture head may become damp.

If you have removed head cover and you need to interrupt your work for longer time (hours, days), we recommend to place the head cover on the head and fasten it provisionally by means of two screws, next possibility is unscrewing small boxes with silica gel from the head and put it to a sealed container with limited access of air (e.g. sealed plastic bag).

The same rule should be kept for silica gel desiccants in the fixture base in case of service intervention (at removing bottom base cover).

Replacing the fuse.

Before replacing the fuse, disconnect the fixture from mains.

1. Remove the cover (1) of the battery and fuse compartment by unscrewing four screws (4) with sealing rings (3).
2. Using a flat-blade screwdriver, unscrew (anti-clockwise) the fuse holder from the rear panel of the base.
3. Remove the blown fuse from the fuse holder.

4. Place a good fuse (only the same type and rating) into the fuse holder and screw the fuse holder back.
5. Place the cover (1) with gasket (4) back on the rear panel of the fixture and fasten it by means of the four screws (2) with sealing rings (3). Tighten screws crosswise in two steps:
 Step 1 - use tightening torque 0.5Nm (pre-tightening)
 Step 2 - use tightening torque 2.5Nm (final tightening)

Replacing the battery.

Before replacing the battery, disconnect the fixture from mains.

1. Remove the cover (1) of the battery and fuse compartment by unscrewing four screws (2) with sealing rings (3).
2. Loosen (anti-clockwise) the battery holder cap.
3. Remove the exhausted battery from the battery holder.
4. Place a new battery (only the same type) into the battery holder (Negative (-) inside, Plus (+) outside).
5. Place and tighten the battery holder cap back.
6. Place the cover (1) with gasket (4) back on the rear panel of the fixture and fasten it by means of the four screws (2) with sealing rings (3). Tighten screws crosswise in two steps:
 Step 1 - use tightening torque 0.5Nm (pre-tightening)
 Step 2 - use tightening torque 2.5Nm (final tightening)

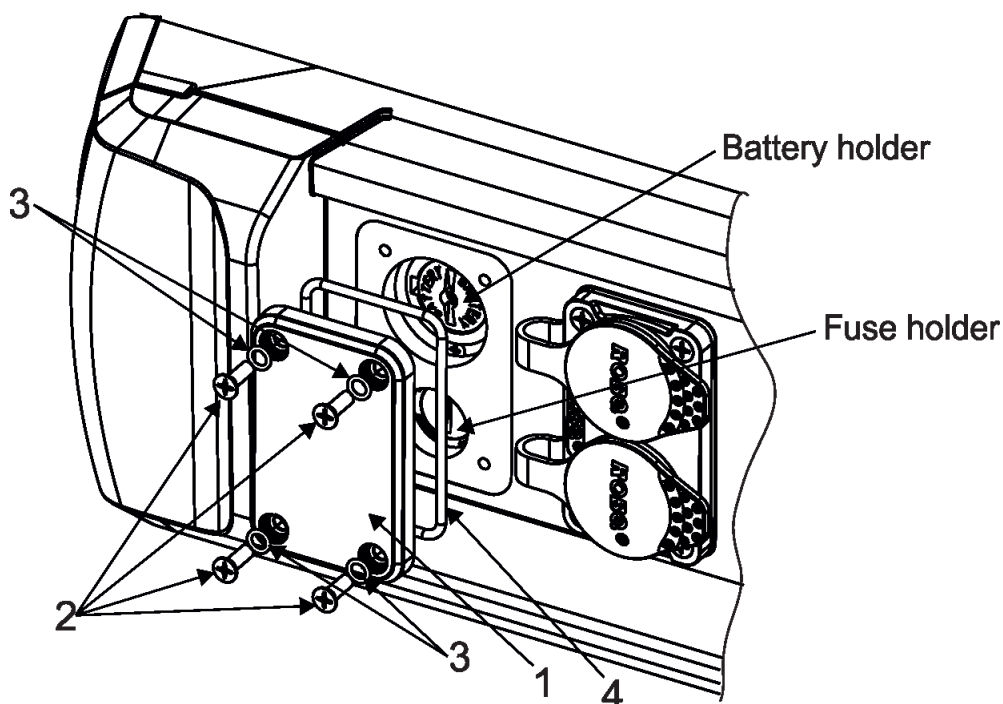

Changing pan/tilt motors or pan/tilt driver.

In case of change of pan motor or tilt motor or pan/tilt control PCB (RB 3138 in the fixture yoke), you have to run the procedure Calibrate Pan/Tilt Reset in the tab "Service" (tab Service--> Calibrations --> Calibrate Pan/Tilt Reset).

14.1 Fixture watertight covers and torques of covers screws

Keep values of torques as stated on pictures below otherwise leakage issues can occur!

Run the procedure Pressure Test (Service --> Pressure Test) after replacing any watertight cover!

Bottom base cover

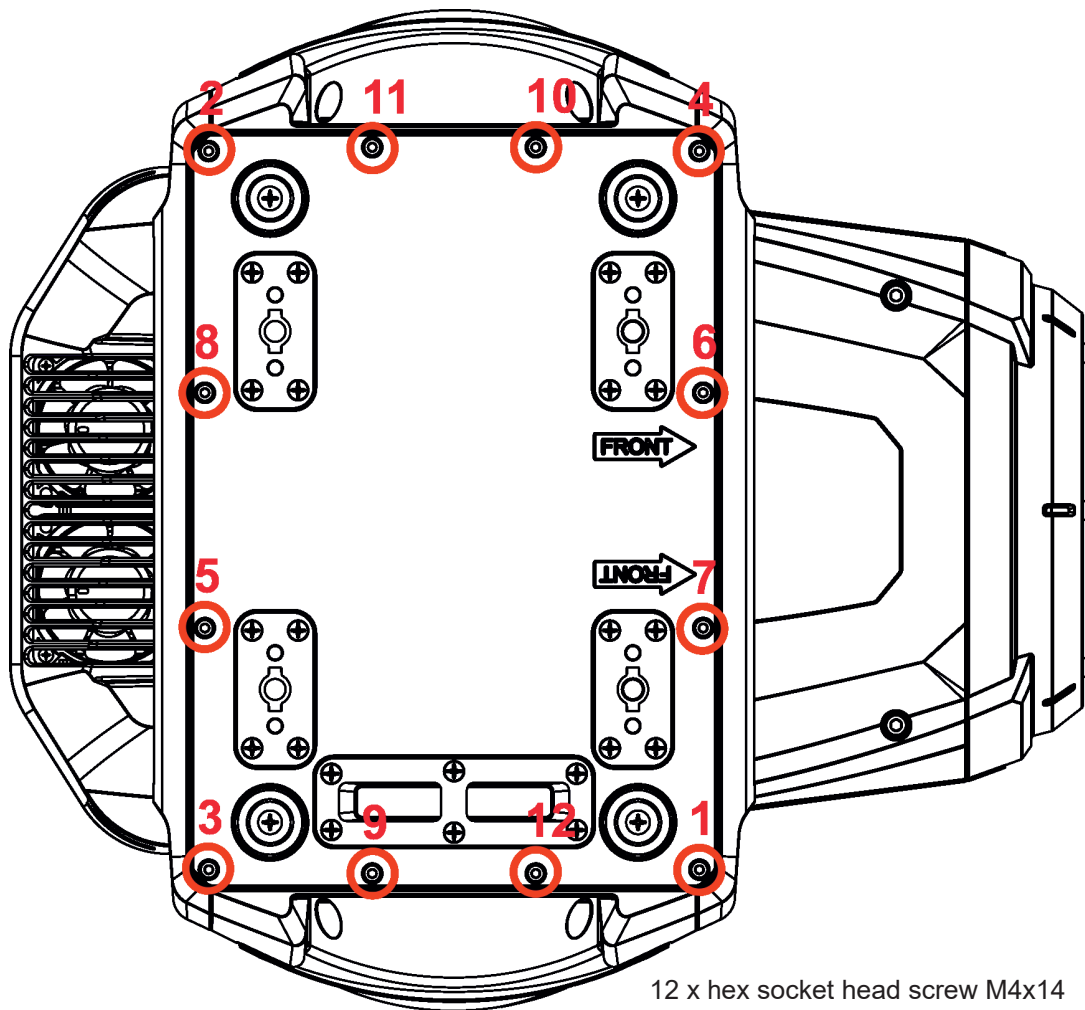

Screws must be tightened in the order 1-->12

12 x hex socket head screw M4x14
12x Spring washer
Tightening torque: 2.2-2.5 Nm*

* Tighten all screws in two steps:
Step 1 - use tightening torque 0.5Nm (pre-tightening)
Step 2- use tightening torque 2.2-2.5Nm (final tightening)

Carefully check the gasket for signs of deformities or damages and if it is correctly placed before screwing the bottom base cover back. The gasket is part of the base.
Do not forget to connect grounding wire between chassis and base cover.

Head covers (on both sides of the head)

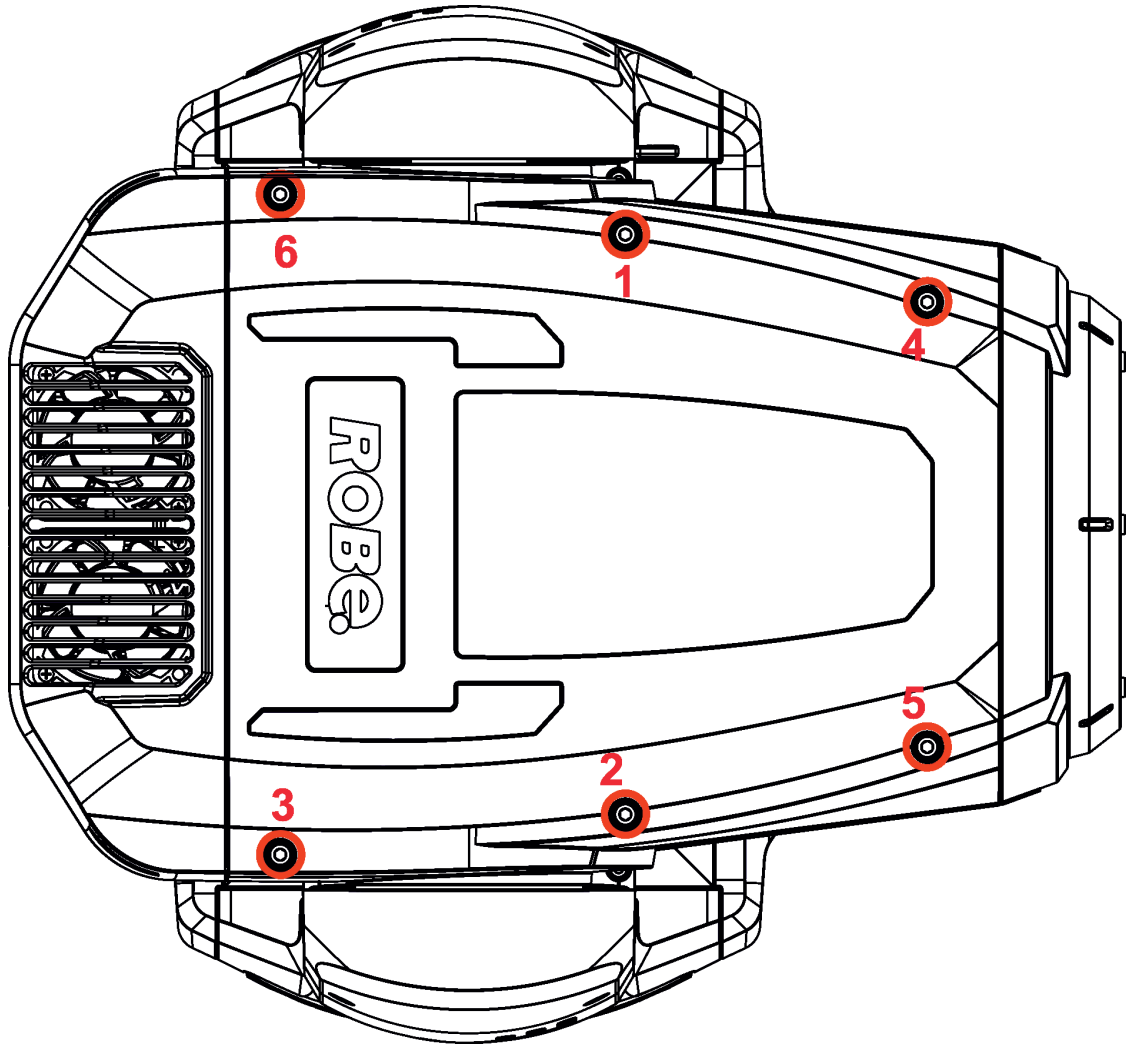

Screws must be tightened
in the order 1-->6

6 x hex socket head screw M5x16
Tightening torque*: 2.5 Nm

* Tighten all screws in two steps:
Step 1 - use tightening torque 0.5Nm (pre-tightening)
Step 2- use tightening torque 2.5Nm (final tightening)

**Carefully check the gasket for signs of deformities or damages and if it is correctly placed before screwing head covers back. The gasket is part of the head cover.
Do not forget to connect grounding wire between chassis and head cover.**

Yoke cover

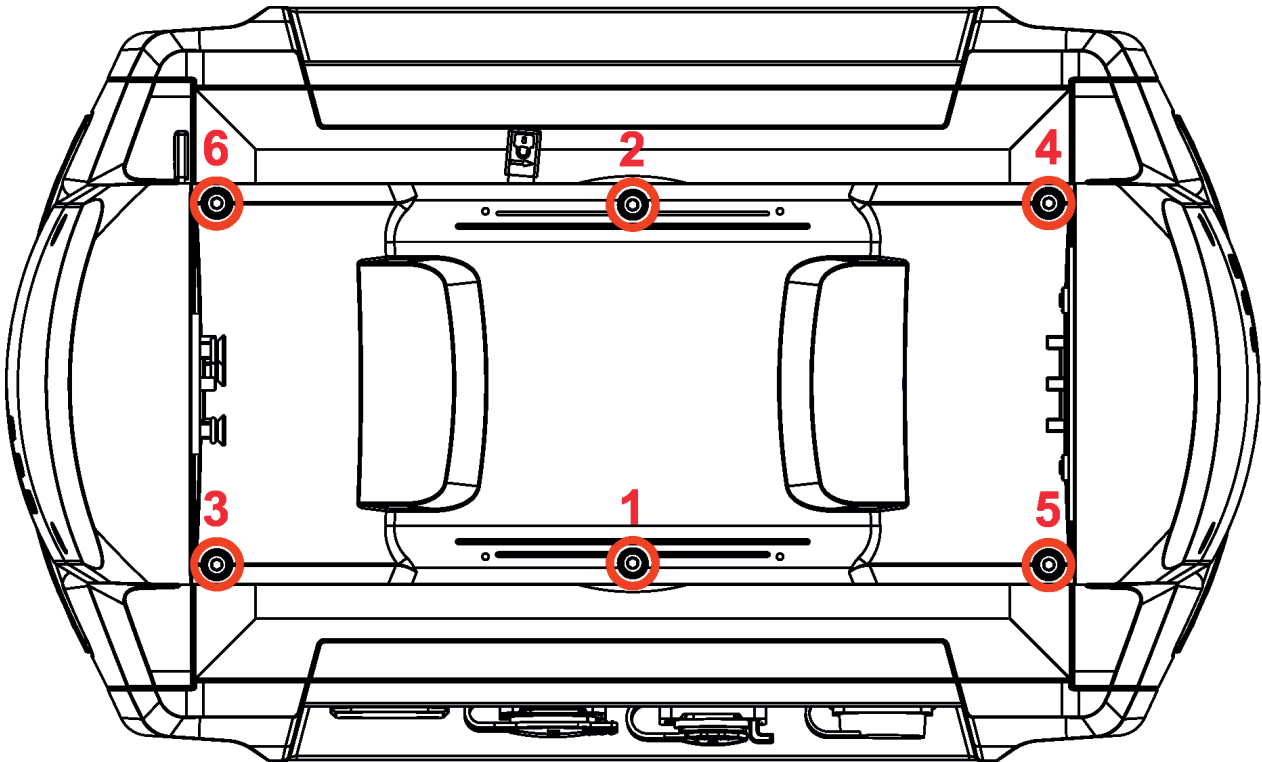

Screws must be tightened
in the order 1-->8,

8 x hex socket head screw M4x8
Tightening torque*: 2.5 Nm

* Tighten all screws in two steps:

Step 1 - use tightening torque 0.5Nm (pre-tightening)

Step 2- use tightening torque 2.5Nm (final tightening)

Carefully check the gasket for signs of deformities or damages and if it is correctly placed before screwing the yoke cover back. The gasket is part of the yoke cover.

Do not forget to connect grounding wire between chassis and base cover.

14.2 Torques of Pan/Tilt motors screws

In case of change of pan motor or tilt motor or pan/tilt control PCB (RB 3138 in the fixture yoke), you have to run the procedure Calibrate Pan/Tilt Reset in the tab "Service" (tab Service--> Calibrations --> Calibrate Pan/Tilt Reset).

Tilt motor

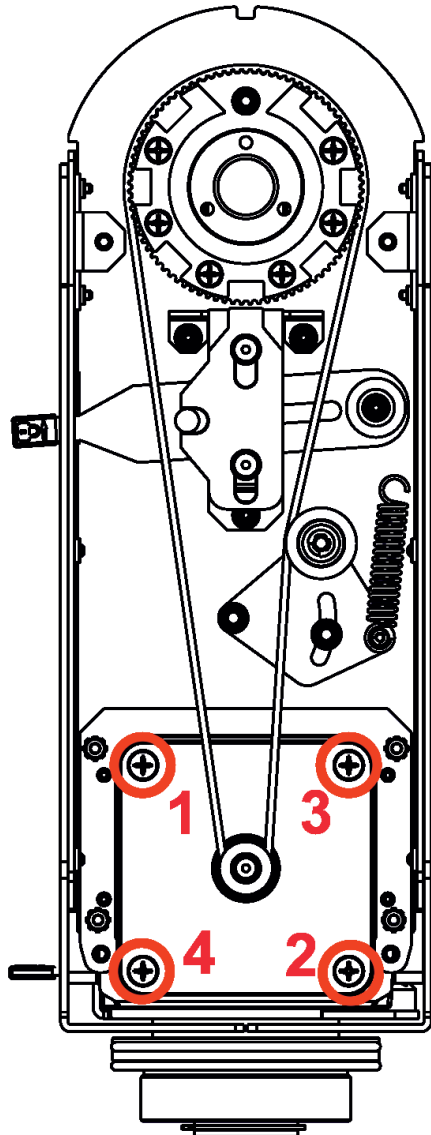

4 x flat head screw M5x16 (stainless)
with sealing ring 5x1.5
Tightening torque*: 2.5 Nm

Screws must be tightened in the order 1-->4,
Use LOXEAL 55.03 (nut locking threadsealing)
on each screw

* Tighten all screws in two steps:
Step 1 - use tightening torque 0.5Nm
(pre-tightening)
Step 2- use tightening torque 2.5Nm
(final tightening)

Pan motor

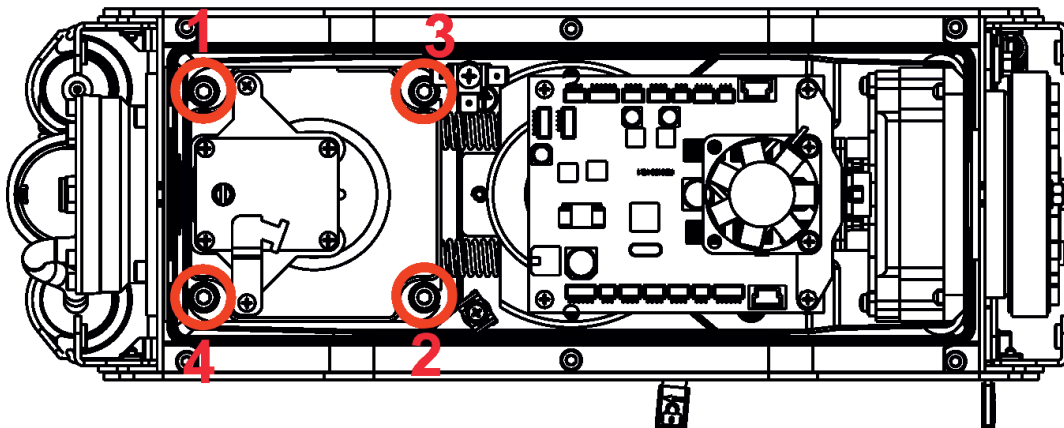

4 x hex socket head screw M5x20 (stainless) with
washer
Tightening torque*: 2.5 Nm

Screws must be tightened in the order 1-->4.
Use LOXEAL 55.03 (nut locking threadsealing)
on each screw

* Tighten all screws in two steps:
Step 1 - use tightening torque 0.5Nm (pre-tightening)
Step 2- use tightening torque 2.5Nm (final tightening)

14.3 Changing the LED light source

The Robin iPainte allows you to change the LED light source and this way keep a high performance of the fixture.

***Unplug the fixture from mains before replacing LED light source!
Do not change LED light source in a damp environment (e.g. rain, snowfall)!***

To change the LED light source.

1. Disconnect the fixture from mains and allow it to cool about 60 minutes.
2. Lock the head in a horizontal position.
3. Remove the rear cover (1) of the fixture head by unscrewing two screws M5x20 (2) on each side of the cover.

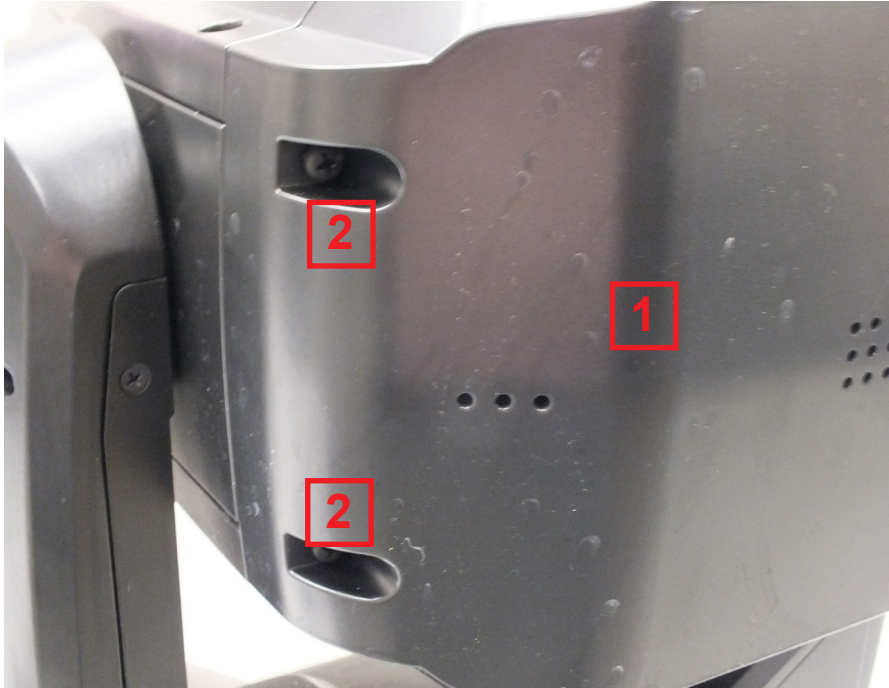

4. Unscrew the four screws M4x14 (4) and the four screws M4x14 (5) and remove the LED light source (6) from the head. Be careful, the LED light source is heavy.

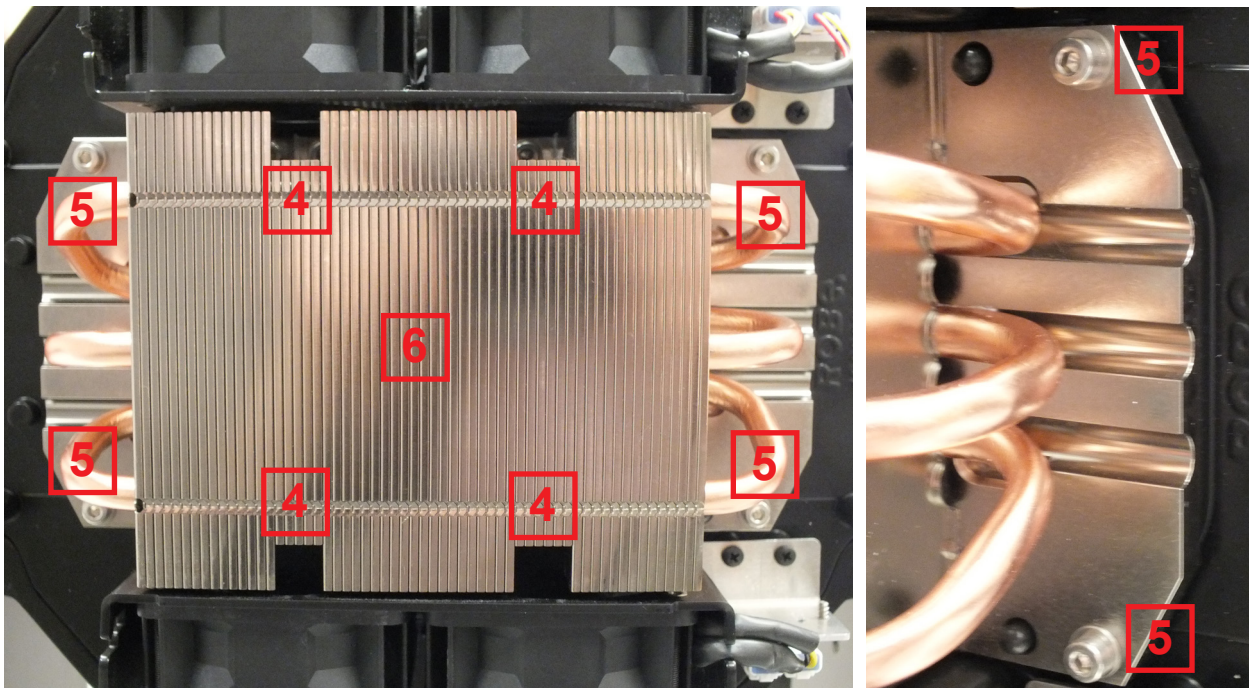

Fixture head without the LED light source.

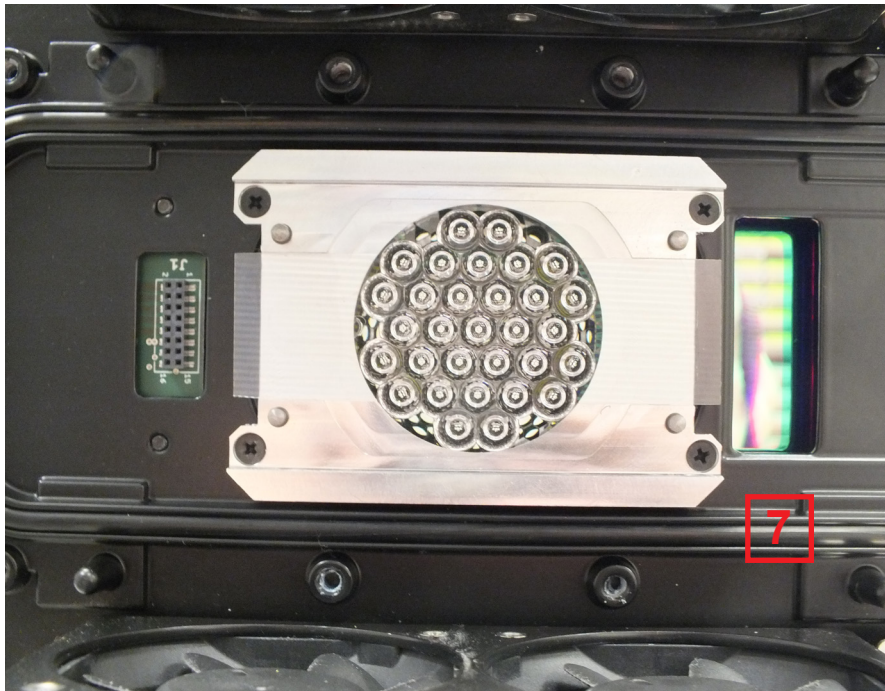

Important: Carefully check the gasket (7) for signs of deformities and if it is correctly placed in the chassis of the head before inserting the new LED light source.

The new LED light source includes PCB with LEDs and heat sink. Handle with care. Do not touch LEDs with bare hands.



5. Carefully insert the new LED light source to the head. **Keep the correct orientation of the LED light source towards the head chassis as shown on the picture below. The connector on LEDs PCB has to be oriented towards the connector on the fixture chassis.**

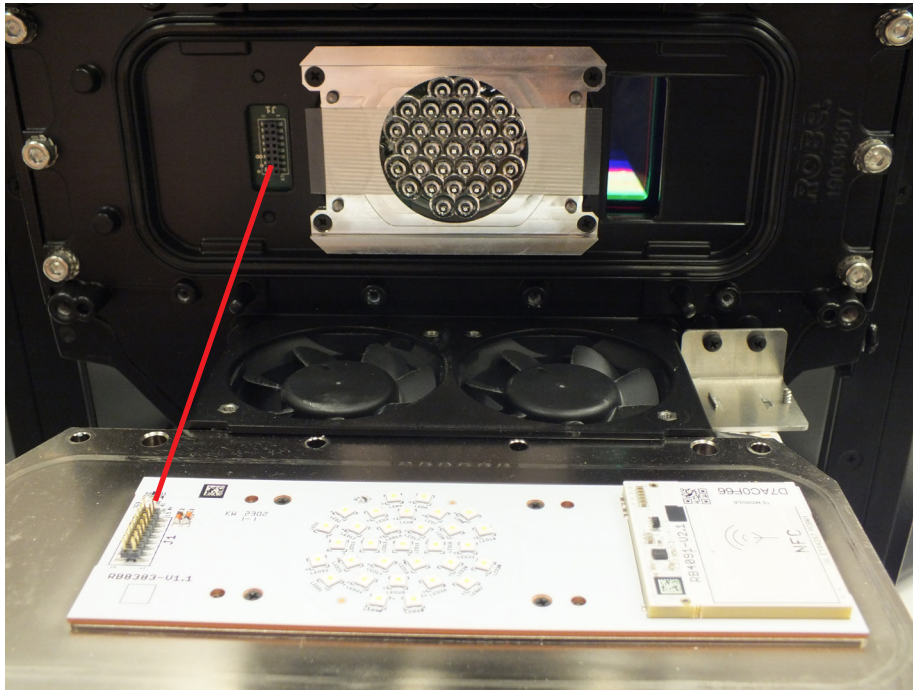

The four guide pins (8) secure correct position of the LED light source.

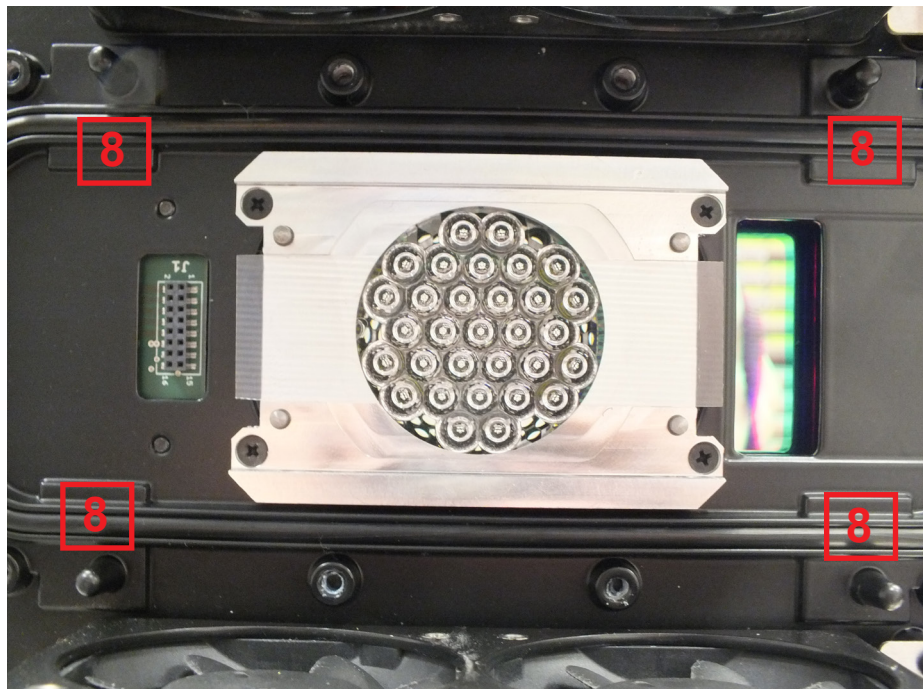

6. Tighten the four outside fastening screws M4x14 (4) in the order 1-->4. Use tightening torque 2.5 Nm. Do the tightening of screws in two steps, in the first step use tightening torque 0.5 Nm and in the second step 2.5 Nm.

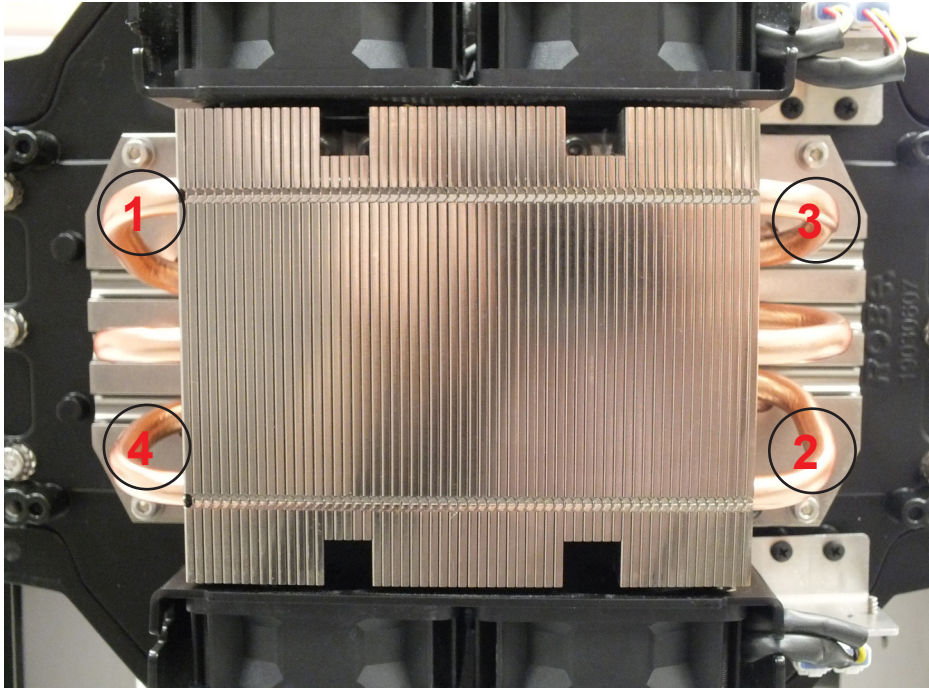

Tighten the four fastening screws M4x14 (5) in the order 1-->4. Use tightening torque 2.5 Nm. Do the tightening of screws in two steps, in the first step use tightening torque 0.5 Nm and in the second step 2.5 Nm.

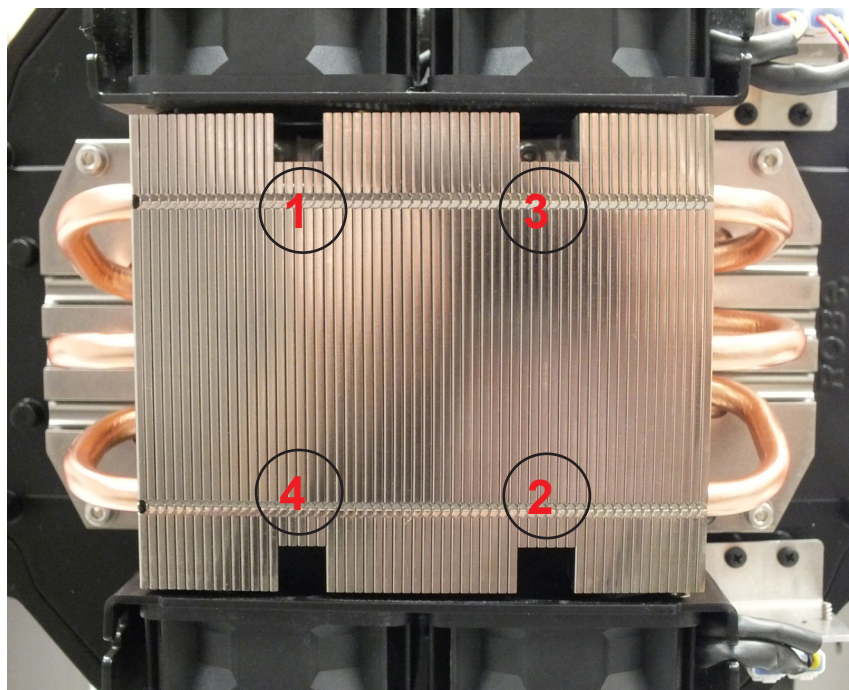

Note: Check that all screws are firmly tightened. Fastening of the LED light source has to be watertight.

7. Screw the rear cover (1) of the fixture head by means of four screws M4x20 (2).

8. **After connecting the fixture to mains, run the procedure Pressure Test (Service -->Pressure Test).**
If the pressure test is not OK, check tightening of the LED light source and run the pressure test again.

14.4 Checking and replacing the silica gel desiccants

The silica gel desiccants are used for humidity indication in the fixture. Dry silica gel has an orange colour, if it is saturated with water, its colour changes to dark grey. If most of silica gel changed colour to dark grey, it has to be replaced.

***Unplug the fixture from mains before checking/replacing silica gel desiccant!
Do not check/replace silica gel desiccant in a damp environment (e.g. rain, snowfall)!***

***Spare desiccants from factory are packaged in a protective foil. Take desiccants out of the protective foil immediately before replacing them in the fixture!
Silica gel may become damp if it is exposed to wet air for longer time.***

Silica gel is not under warranty!

Desiccants are placed in the fixture on the following places:

fixture head - 1 x small box with silica gel

fixture arm (without tilt lock) - 2 x tube with silica gel

fixture base - 2 x small box with silica gel

Total weight of silica gel fillings in the fixture is 96 g.

Fixture head

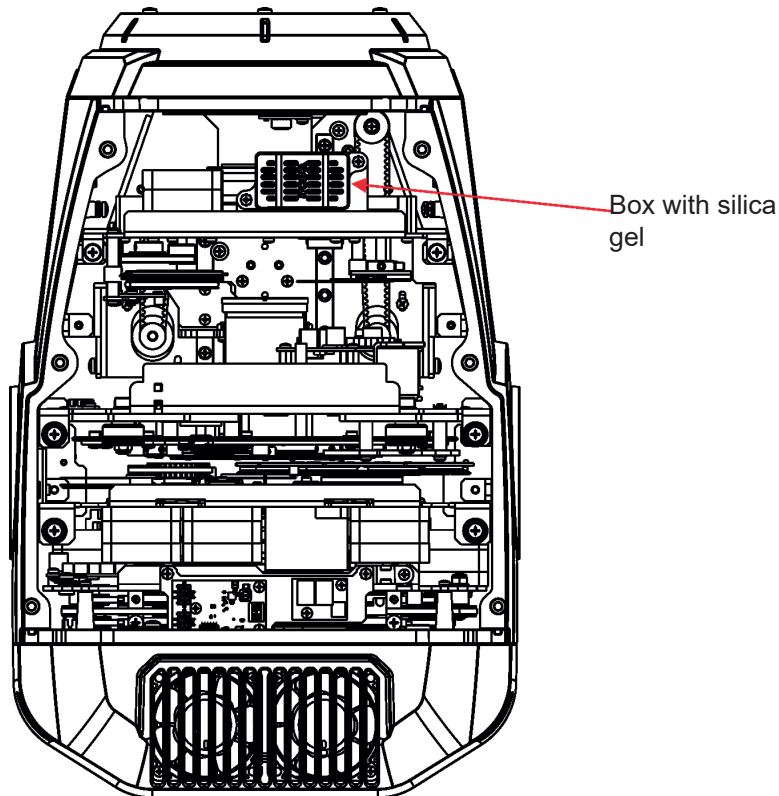

Fixture base

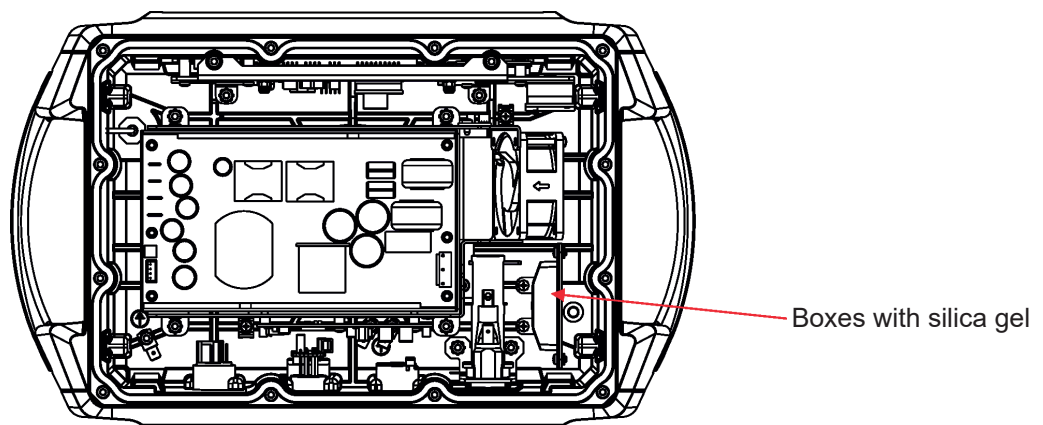

Each silica gel box is fastened in the fixture by means of two screws.

Example:

Dry silica gel

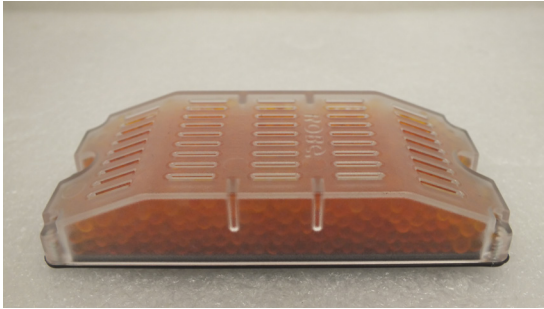

Silica gel saturated with water

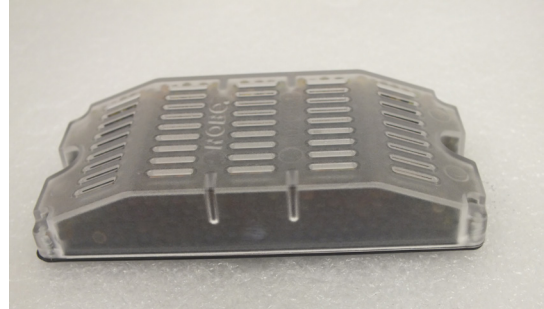

The silica gel desiccants in the fixture head should be checked (and alternatively replaced) at removing head covers, e.g. at gobos change.

The silica gel desiccants in the fixture base should be checked (and alternatively replaced) at removing bottom cover e.g. at service intervention.

After checking/replacing boxes with silica gel do not forget to connect grounding wire between chassis and base cover (head cover) at placing the covers back.

After checking/replacing boxes with silica gel, run the procedure Pressure Test (Service -->Pressure Test).

If the pressure test is not OK, check if all screws of head covers (base cover) are correctly tightened.

Fixture arm

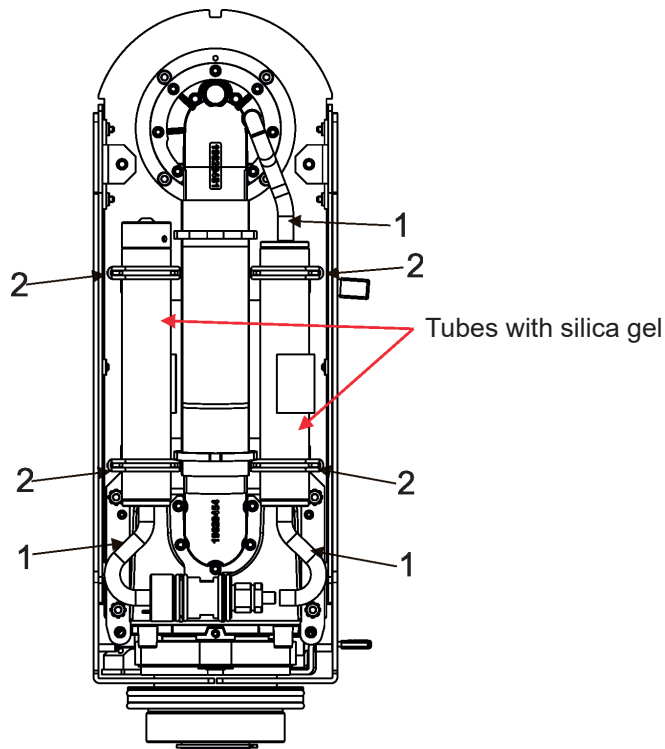

To change the tube with silica gel:

1. Disconnect the fixture from mains.
 2. Remove the arm cover.
 3. Disconnect the hosepipe(s) (1) from the tube with silica gel.
 4. Stick out the rubber rings (2) and remove the tube with silica gel.
 5. Insert the new tube with silica gel and secure it by means of the rubber rings (2).
 6. Connect the hosepipe(s) (1) to the tube with silica gel.
 7. Screw the arm cover back.
 8. **After connecting the fixture to mains, reset the MAX WET chart (tab Information-->RAINS Status) and run the procedure Pressure Test (tab Service -->Pressure Test).**
- If the pressure test failed, check if hose-pipes are correctly put on the tubes with silica gel.

Example of dry silica gel and silica gel saturated with water:

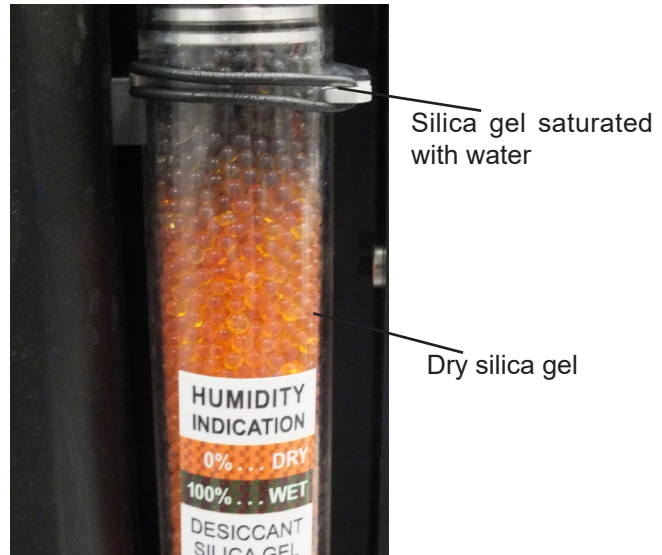

- State of desiccants in the fixture arm can be checked:
 - visually by unscrewing the cover of fixture arm
 - via fixture display (tab Information, option RAINS Status):

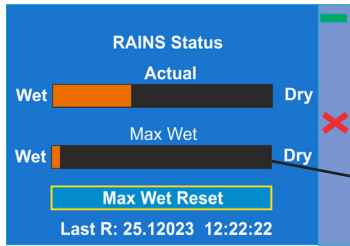

- remotely by means of the Robe Ethernet Access Portal (REAP):

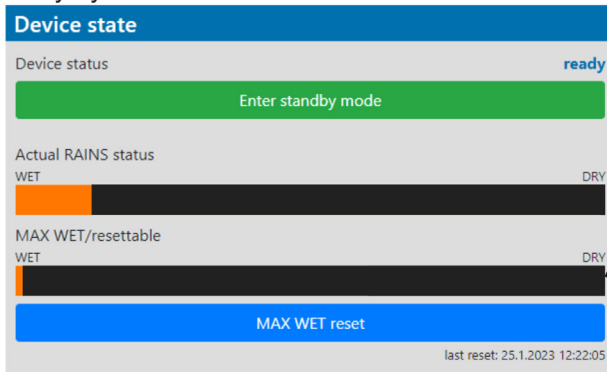

The chart MAX WET is decisive for replacing dessicants in the fixture arm. If the chart has changed to black colour, dessicants have to be replaced.

It is not necessary to replace silica gels dessicants in plastic boxes in the fixture head and base. These dessicants should be checked (and replaced if it is needed) at removing head or base covers, e.g. at gobo replacement or some service intervention.

In case that silica gel in the fixture arm is fully saturated with water, the warning message "**Too Much Humidity in Device**" will appear on the fixture display (yellow warning icon) and also in the Robe Ethernet Access Portal (Logs screen).

Example



14.5 Disposing of the product

To preserve the environment please dispose or recycle this product at the end of its life according to the local regulations and codes.

15. Obtaining information about the LED light source by mobile phone

You can read information about the LED light source by means of the mobile application ROBE COM. The LED light source has to be outside of the fixture.

Download and install the application ROBE COM from Google Play (for Android 5.0 and higher) or App Store (for iOS 12.0 and higher) to your mobile phone. Your mobile phone has to support NFC (Near-Field Communication).

After installing the ROBE COM, run the application by touching the icon  . The following screen will appear:

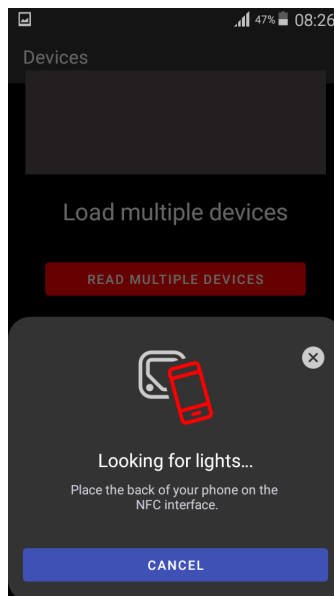

Hold the mobile phone close to the point of the LED light source PCB which is marked with the symbol NFC.

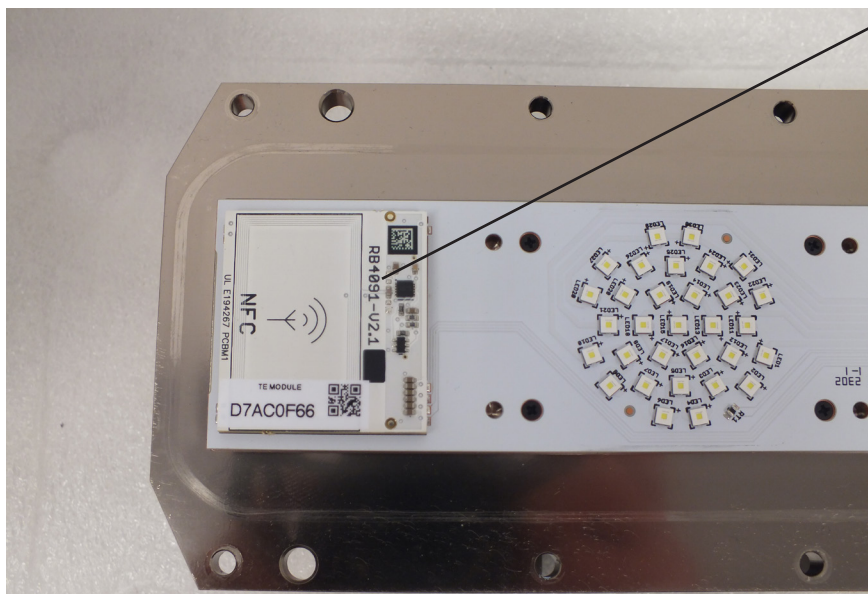

If NFC connection is OK, the screen with RDM UID of the LED light source will appear.

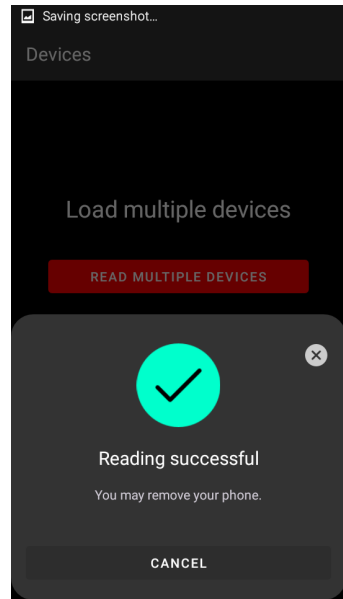
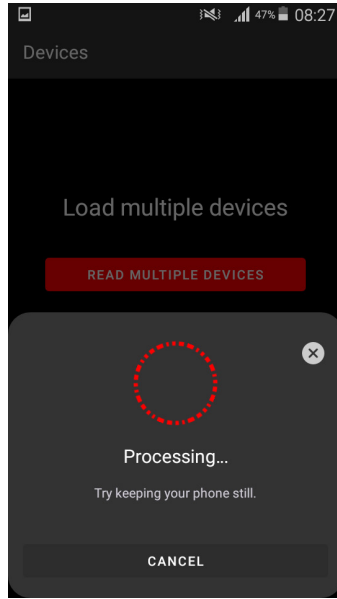
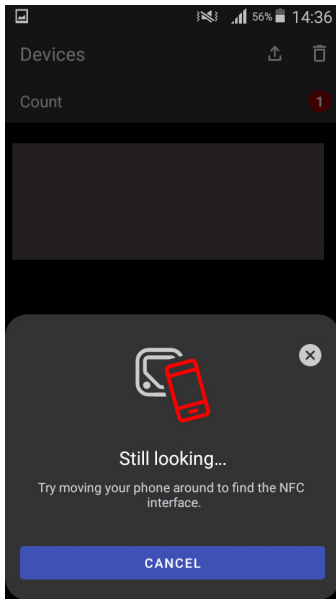

When the following screen will appear, touch the button CANCEL.

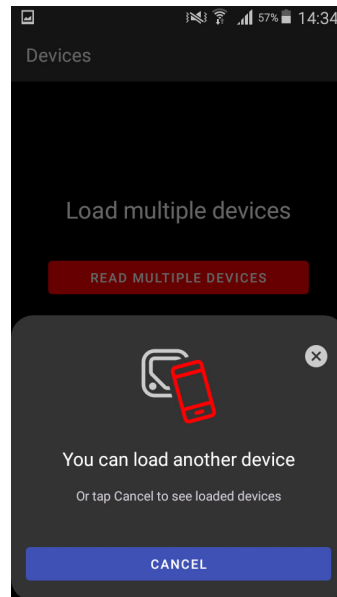

Touch the found LED module ("Robin iPainte LED module") and then touch "LED engine" to read information about found LED module.

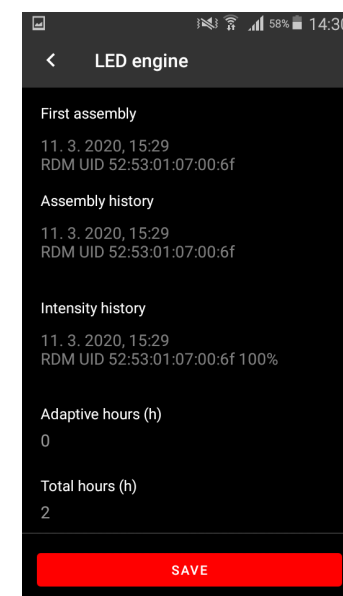
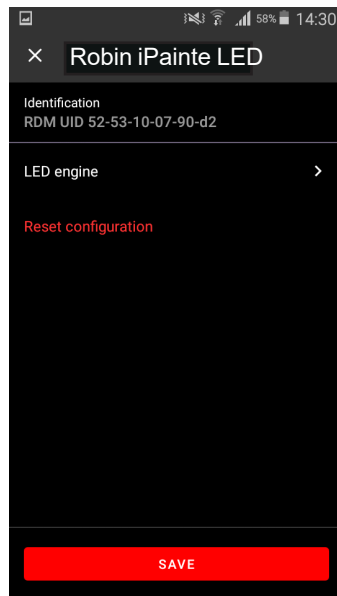
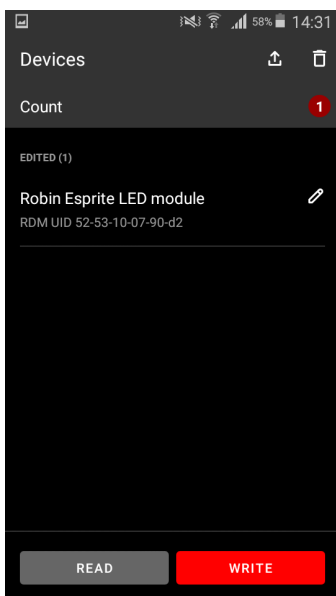

16. Robe Ethernet Access Portal (REAP)

Before running the REAP, your computer needs to be connected to the fixture (s) through the means of Ethernet wired network and a network switch. The computer needs to have configured network settings in order to be able to communicate with the fixture(s) through the network. The Ethernet network connection (Local LAN) typically needs to be set to 2.x.x.x address, the computer IP address has to be set to 2.x.x.x (for example 2.247.136.20) with netmask 255.0.0.0. On the fixture make sure to use the default 2.x.x.x IP address as provided. You do not need change any IP settings on the fixture, there is no need to set the fixture into Art-Net mode.

Type the IP address of the iPainte to your web browser, e.g. `http://2.247.196.37`, enter the user name: **robe** and the password: **2479**, the **Status screen** of the iPainte will appear.

The screenshot displays the Robe iPainte Status screen. It features a top navigation bar with the Robe logo and menu items: Status, Personality, Logs, RAINS logs, Discovery, and Settings. The main content area is divided into several panels:

- DMX/RDM settings:** Lists DMX address (221), DMX preset (Mode 1 (44 channels)), DMX input (wired), IP address (2.247.196.37), MAC address (00:0d:19:06:c4:25), RDM UID (52:53:01:35:00:25), and RDM label (iPainte).
- Device times:** Shows Power on time (131h / 128h total / resettable, adaptive), LED on time total (48h), and LED on time adaptive (40h).
- Device temperatures:** Displays temperatures for LEDs (29°C / 65°C / 65°C), Driver (30°C / 80°C / 80°C), and Base (33°C / 53°C / 53°C), with a note for current / maximum / resettable.
- Wireless state:** Shows State (linked) and Signal strength (0.0%).
- Software versions:** Lists versions for Display System (1.2), Module M (1.2), Module L (1.0), Module O (1.1), Module F-A (1.1), Module F-B (1.1), Module G (1.0), Module C (1.0), Module P (1.1), and Module DL (1.1).
- Device state:** Shows Device status (active), a green 'Enter standby mode' button, Current RAINS status (WET), MAX WET/resettable (WET), and a blue 'MAX WET reset' button. A note indicates 'last reset: 14.4.2023 15:24:48'.
- Status messages:** A section at the bottom for displaying messages.

This screen gives you a fast overview of fixture settings and environment in the fixture. The icon  allows you to change some values in a corresponding table.

Example for DMX/RDM settings:

The screenshot shows the Robe iPainte Status screen with the 'DMX/RDM settings' dialog box open. The dialog box contains the following fields:

- DMX address:** 221
- DMX preset:** Mode 1
- DMX input:** wired
- RDM label:** iPainte

A blue 'Save' button is located at the bottom right of the dialog box. The background shows the same Status screen as in the previous image, but with a semi-transparent overlay.

Note.

The background colour of the top row of the Status screen with the name and RDM label of the fixture denotes state of the fixture:

-  fixture is ready for operation
-  fixture does not communicate with computer
-  fixture with error message(s)

The table "Device state" gives you information about fixture and environment in the fixture.

Device status: **ready** - all fixture resets successfully passed and the fixture is ready for operation.

initialization - fixture is waiting for fixture reset

heating - fixture is waiting for reaching operating temperature of the fixture inside (temperature in the fixture is below 0°C).

standby - the fixture is in standby mode

standby/heating - the fixture is in standby mode and inside of the fixture is heated

The bar chart **Actual RAINS status** informs you about current humidity in the fixture. The bar chart changes depending on humidity, temperature and pressure in the fixture. The bar chart depends on current conditions in the fixture and can be different at start of fixture operation, after 10 minutes of its operating, after closing fixture dimmer etc.

RAINS (Robe Automatic Ingress Neutralization System) manages humidity, temperature and pressure control using an active monitoring system to automatically remove any moisture detected within the fixture and provides permanent monitoring to ensure peak performance of the fixture.

The bar chart **MAX WET/resettable** informs you about maximum humidity achieved in the fixture since the chart was last reset. The bar chart also informs you about saturation of silica gel desiccants in the fixture arm with water and is deciding indicator for their checking and replacement.

The blue button **MAX WET reset** resets the bar chart MAX WET/resettable. Date and time of last reset is displayed below this button.

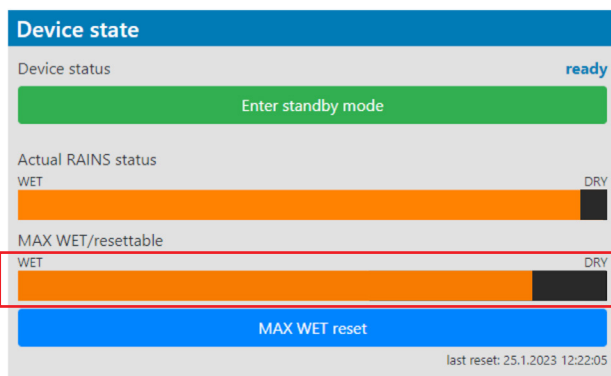

Silica gel desiccants in the fixture arm



Examples of the table "Device state":

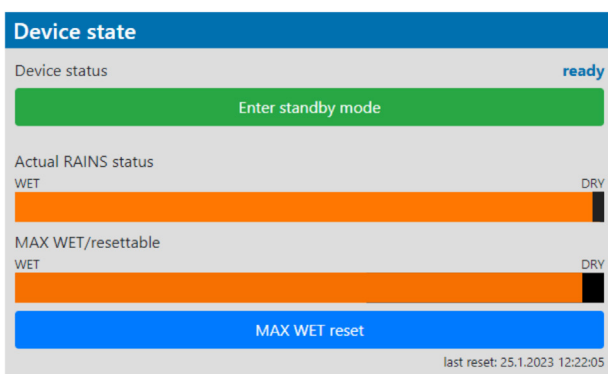

Dry desiccants

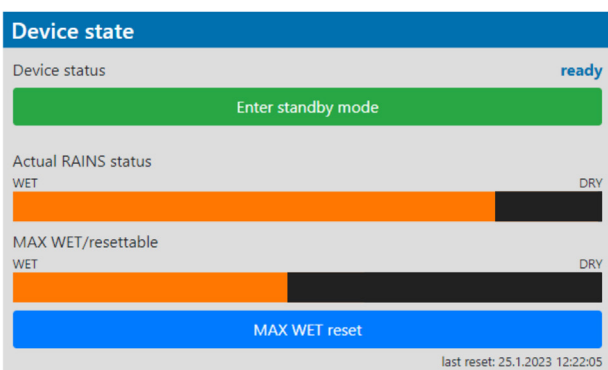

Desiccants partially saturated with water

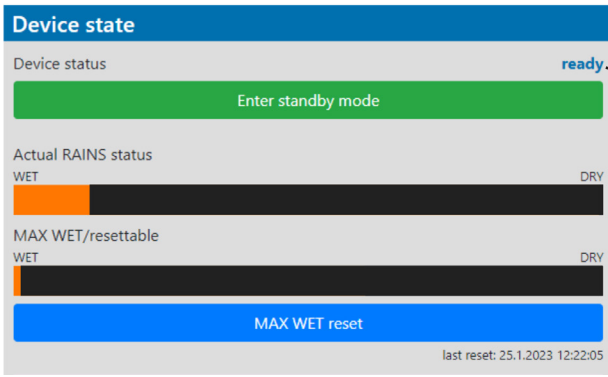

Device status **ready** means, that all fixture resets are OK and the fixture is ready for operation. It does not assess state of desiccants or result of pressure test!

Desiccants fully saturated with water

Silica gel desiccants in the fixture arm should be replaced.

After replacing them, reset MAX WET resettable bar chart.

It is not necessary to replace silica gels desiccants in plastic boxes in the fixture head and base. These desiccants should be checked (and replaced if it is needed) at removing head or base covers, e.g. at gobo replacement or some service intervention.

The option **Enter standby mode** allows you to switch the fixture to Standby mode.

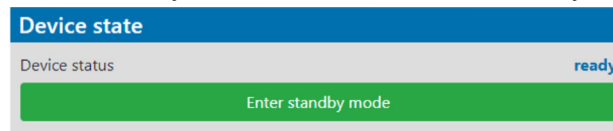

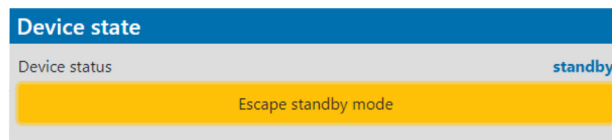

Note: Standby mode helps conserve power when a fixture is not in use, without fully powering it off. In the Standby mode, all fixture motors and fans are deactivated and light output is closed. For more information about Standby mode please see the chapter Standby mode.

The option **Escape standby mode** allows you to switch the fixture to standard operating mode.

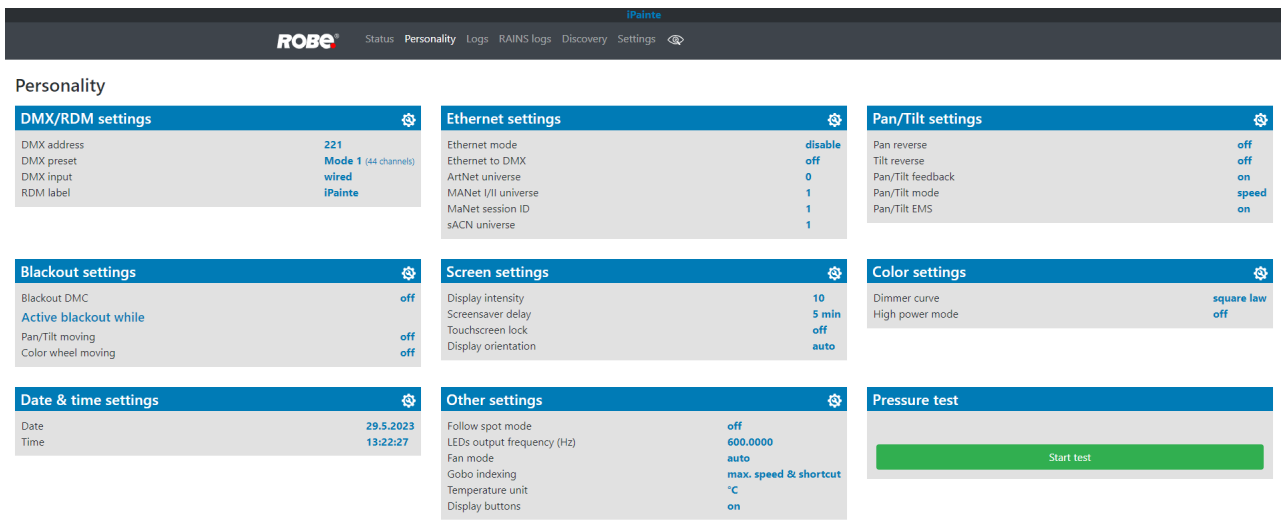

The **Personality** screen allows you to set fixture behaviour and run a pressure test.



The icon  allows you to change values in a corresponding table.

Example for Pan/Tilt settings:

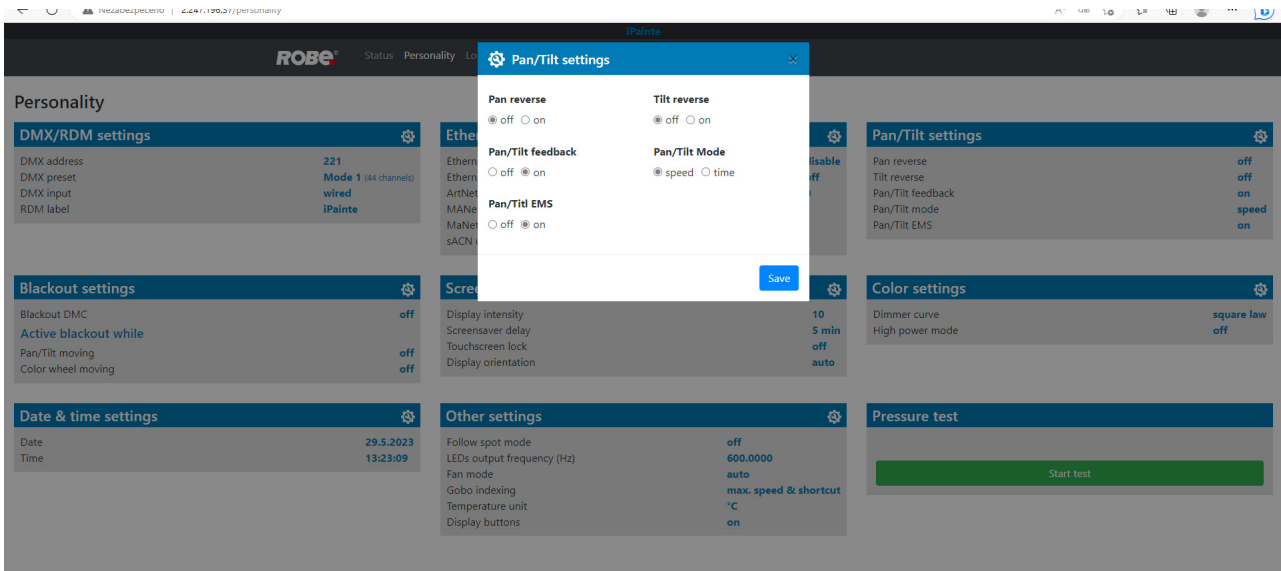

The table "Pressure test " with green button **Start test** allows you to run a procedure which checks IP65 integrity of the fixture. The fixture has to be connected to mains and the head temperature (at pressure sensor) cannot be higher than 55°C. The pressure test lasts about 5 minutes and can be run at earliest 10 minutes after closing light output (shutter closed) of the fixture. The pressure test can be repeated at earliest 2 minutes after last pressure test.

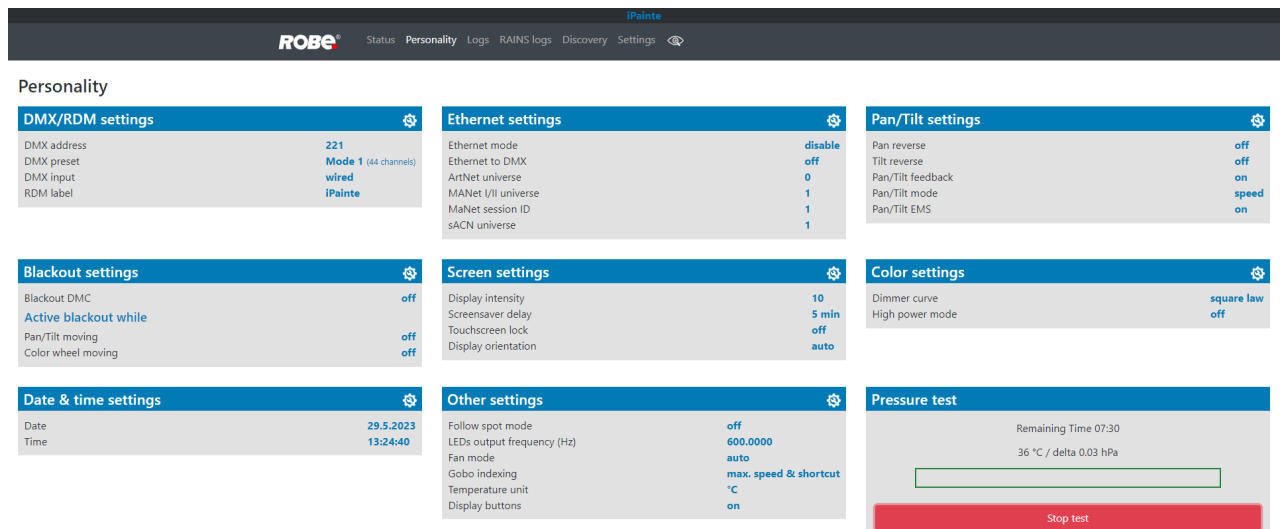

Examples of pressure test messages:

Pressure test is 10 minutes delayed due to fixture cooling

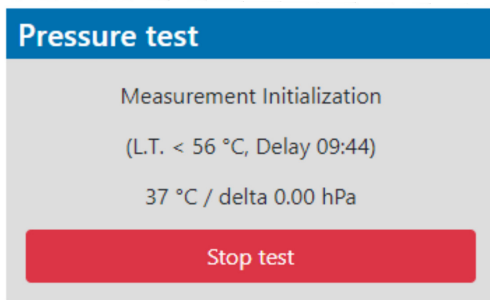

Pressure test is running

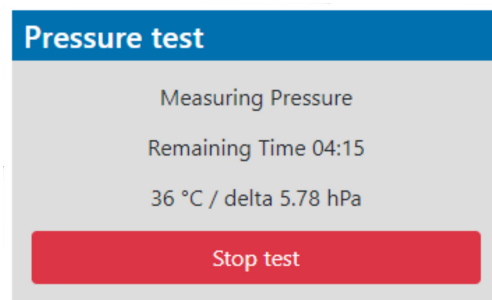

Pressure test passed

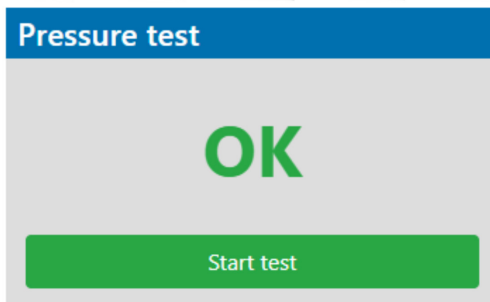

Pressure test failed

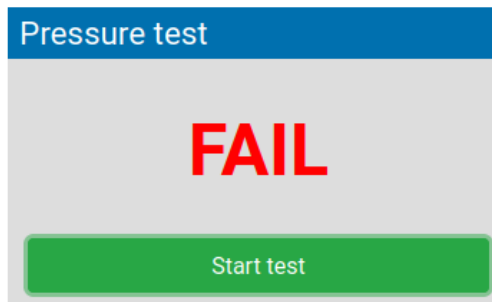

The **screen Logs** displays operating information of the fixture which have been saved.

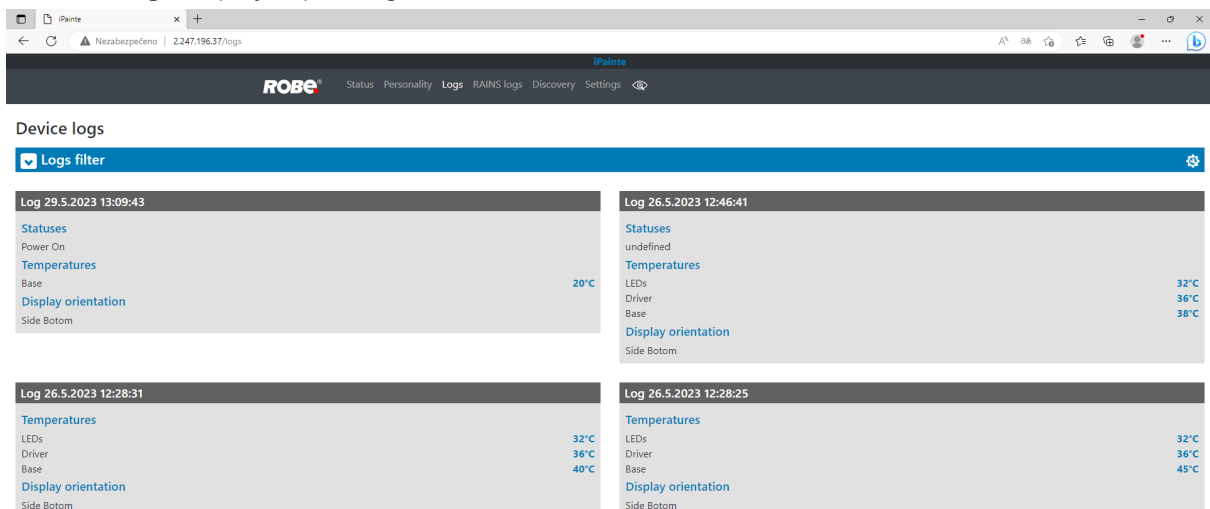

The icon  offers you two options:

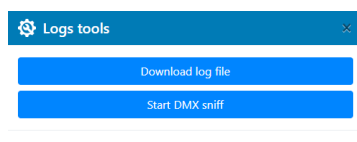

"Download log file" - the option allows you to download the log file to computer, name of the log file is: file-abcd.log, where abcd is a fixture ID (e.g. file-015e.log).

"Start DMX sniff" - the option starts saving coming DMX values to the file, the file name is DMX_sniffer.log).

The option **Logs filter** allows you to select desired group of recorded errors and recorded operating values.

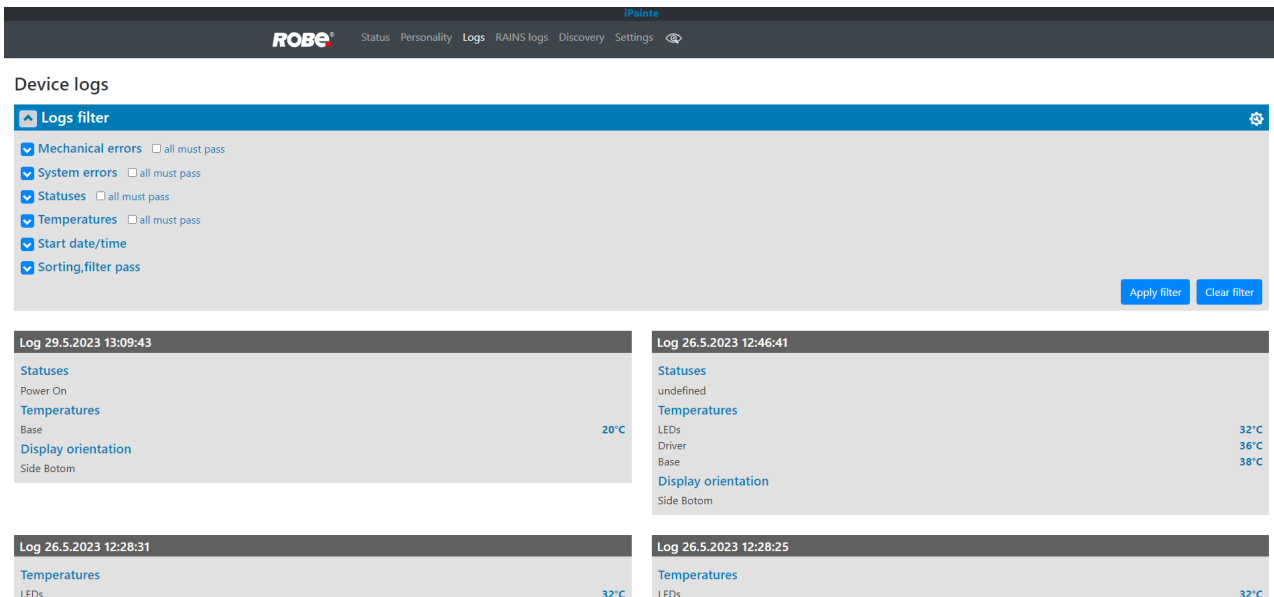

Device logs

Logs filter

- Mechanical errors all must pass
- System errors all must pass
- Statuses all must pass
- Temperatures all must pass
- Start date/time
- Sorting, filter pass

Apply filter Clear filter

Log 29.5.2023 13:09:43

Statuses
Power On

Temperatures
Base 20°C

Display orientation
Side Bottom

Log 26.5.2023 12:46:41

Statuses
undefined

Temperatures
LEDs 32°C
Driver 36°C
Base 38°C

Display orientation
Side Bottom

Log 26.5.2023 12:28:31

Temperatures
LEDs 32°C

Log 26.5.2023 12:28:25

Temperatures
LEDs 32°C

Expanded menu **Logs filter**

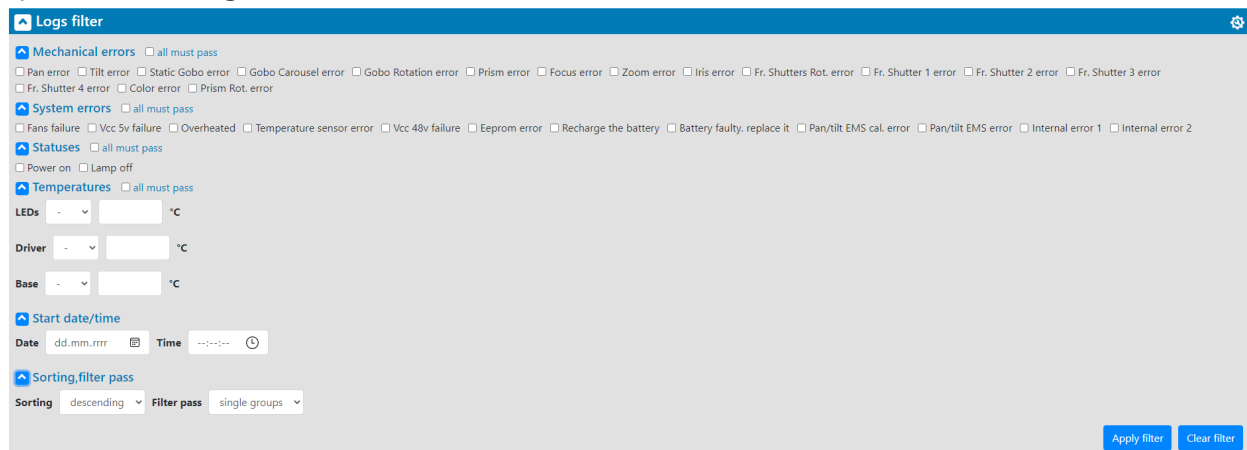

Logs filter

Mechanical errors all must pass

Pan error Tilt error Static Gobo error Gobo Carousel error Gobo Rotation error Prism error Focus error Zoom error Iris error Fr. Shutters Rot. error Fr. Shutter 1 error Fr. Shutter 2 error Fr. Shutter 3 error Fr. Shutter 4 error Color error Prism Rot. error

System errors all must pass

Fans failure Vcc 5v failure Overheated Temperature sensor error Vcc 48v failure Eeprom error Recharge the battery Battery faulty, replace it Pan/tilt EMS cal. error Pan/tilt EMS error Internal error 1 Internal error 2

Statuses all must pass

Power on Lamp off

Temperatures all must pass

LEDs - °C

Driver - °C

Base - °C

Start date/time

Date dd.mm.yyyy Time --:--:--

Sorting, filter pass

Sorting descending Filter pass single groups

Apply filter Clear filter

If the option "all must pass" is checked, only logs which contain all selected errors will be displayed.

Menu "Sorting filter pass" --> option "single groups" means that logs which contain at least one selected error will be displayed.

Menu "Sorting, filter pass" option "all groups" means that logs which contain all selected error will be displayed.

The **screen RAINS Logs** offers you a list of physical values recorded by sensors inside the head.

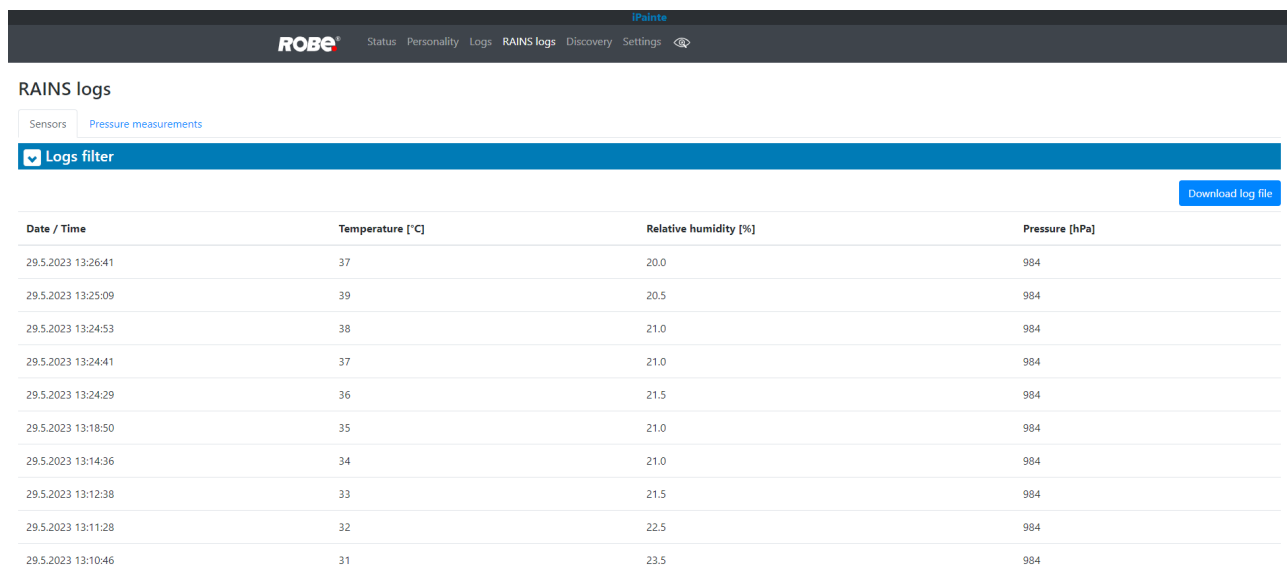

RAINS logs

Sensors Pressure measurements

Logs filter

Download log file

Date / Time	Temperature [°C]	Relative humidity [%]	Pressure [hPa]
29.5.2023 13:26:41	37	20.0	984
29.5.2023 13:25:09	39	20.5	984
29.5.2023 13:24:53	38	21.0	984
29.5.2023 13:24:41	37	21.0	984
29.5.2023 13:24:29	36	21.5	984
29.5.2023 13:18:50	35	21.0	984
29.5.2023 13:14:36	34	21.0	984
29.5.2023 13:12:38	33	21.5	984
29.5.2023 13:11:28	32	22.5	984
29.5.2023 13:10:46	31	23.5	984

You can select range of temperature, humidity and pressure in desired time interval.

The screenshot shows the 'RAINS logs' section of the ROBE iPainte interface. It features a 'Logs filter' panel with input fields for 'Start date', 'End date', 'Temperature' (in °C), 'Relative humidity' (in %), and 'Pressure' (in hPa). There are 'Apply filter', 'Clear filter', and 'Download log file' buttons. Below the filter is a table with the following data:

Date / Time	Temperature [°C]	Relative humidity [%]	Pressure [hPa]
29.5.2023 13:26:41	37	20.0	984
29.5.2023 13:25:09	39	20.5	984
29.5.2023 13:24:53	38	21.0	984

Tab Pressure measurements shows history of pressure tests.

The screenshot shows the 'Sensors' tab in the ROBE iPainte interface. It includes a 'Download measurements file' button and a table of pressure measurements:

Date / Time	Temperature [°C]	Relative humidity [%]	Pressure [hPa]	Pressure difference [hPa]	Duration [m:s]	Result
11.1.2023 14:59:17	47	8.5	991	7.03	03:26	OK
10.1.2023 09:45:47	27	11.0	988	7.28	02:32	OK

If you have two and more iPaintes, the **Discovery** screen allows you to show all connected iPaintes in network. Click on the blue button Discover and fixtures connected in the network will be displayed.

The screenshot shows the 'Discovery' screen in the ROBE iPainte interface. It includes a 'Discover (5)' button and a table of discovered devices:

Device	DMX address	DMX preset	RDM UID	IP address	RAINS (max wet)	Device status
iPainte	221	Mode 1 (44 channels)	52:53:01:35:0025	2.247.196.37		active
iForte - iForte 1	1	Mode 1 (54 channels)	52:53:01:2c:00:13	2.247.136.19		active
iForte - iForte 3	1	Mode 1 (54 channels)	52:53:01:2c:00:1a	2.247.136.26		active
iSpilder	1	Mode 1 (49 channels)	52:53:01:1c:00:0e	2.246.236.14		active
iSpilder	1	Mode 1 (49 channels)	52:53:01:1c:03:d8	2.246.239.216		active

The background colour in the device row denotes state of the fixture:

- indicates "server fixture"(fixture of which IP address you have written to your WEB browser).
- indicates fixture ready for operation.
- indicates fixture which does not communicate with computer or "server fixture".
- indicates fixture with error messages.

Example: Fixture which do not communicate with computer are indicated by yellow background.

Device	DMX address	DMX preset	RDM UID	IP address	RAINS (max wet)	Device status
iPainte	221	Mode 1 (44 channels)	52:53:01:35:00:25	2.247.196.37		disconnected
iSpider	1	Mode 1 (49 channels)	52:53:01:1c:00:0e	2.246.236.14		active
iSpider	1	Mode 1 (49 channels)	52:53:01:1c:03:d8	2.246.239.216		active
iForte - iForte 3	1	Mode 1 (54 channels)	52:53:01:2c:00:1a	2.247.136.26		active
iForte - iForte 1	1	Mode 1 (54 channels)	52:53:01:2c:00:13	2.247.136.19		active

If the option Move devices with warning to top is checked, fixtures with some error will be displayed on the top of fixture list.

The option Columns selection allows you to check desired items which will be displayed in columns. Max. 6 items can be selected. After checking desired items, click on the blue button Apply selection to activate selection. Icons allows you to order values in the column in descending or ascending order.

Note: The values of the fixture in the first blue row ("server fixture") will not be included into ordering.

Example.

Device	DMX address	DMX preset	RDM UID	IP address	RAINS (max wet)	Device status
iPainte	221	Mode 1 (44 channels)	52:53:01:35:00:25	2.247.196.37		active
iSpider	1	Mode 1 (49 channels)	52:53:01:1c:00:0e	2.246.236.14		active
iSpider	1	Mode 1 (49 channels)	52:53:01:1c:03:d8	2.246.239.216		active
iForte - iForte 3	1	Mode 1 (54 channels)	52:53:01:2c:00:1a	2.247.136.26		active
iForte - iForte 1	1	Mode 1 (54 channels)	52:53:01:2c:00:13	2.247.136.19		active

Item **ready** in the column Device status does not assess state of desiccants or result of pressure test!

The **screen Settings** allows you to change password to REAP.

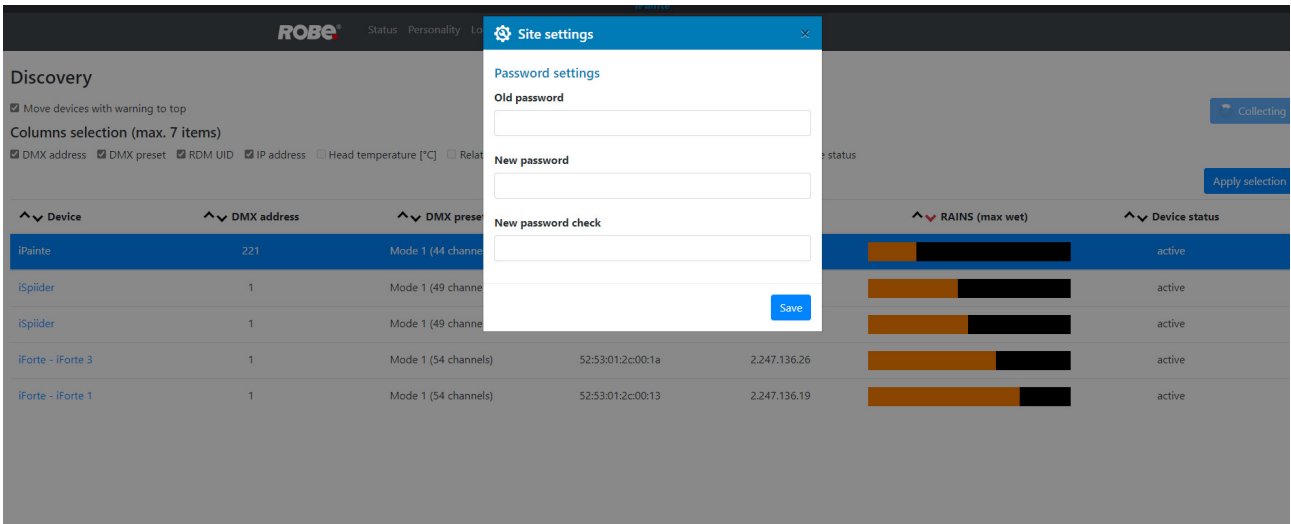

The icon serves for identification of the fixture in a group of fixtures. After clicking on the icon, the fixture's head will start to move.

17. Technical Specifications

Electrical

Power supply: electronic auto-ranging
Input voltage range: 100-240V, 50-60Hz
Fuse: T 6.3A/250V ~
Max. power consumption: 440W (power factor 0.98)

Optic

Light source type: TE-iSE™ 310W HP White LED Engine:
HP - High Performance Engine for maximum light output and optimal colour
Fixture total lumen output: 12.000 lm (goniophotometer)
Colour temperature output: 6.700 K
CRI: 70, remotely selectable filter for CRI 90
Light source type: TE-iSE™ 310W HCF White LED Engine:
HCF - High Colour Fidelity Engine for the best light quality and colour rendition
Fixture total lumen output: 7.800 lm (goniophotometer)
Colour temperature output: 6.000K
CRI: 96, TLCI: 97, TM-30-18 Rf: 92, TM-30-18 Rg: 99
LED life expectancy: min. 50.000 hours
Typical lumen maintenance: L70/B50 @ 50.000 hours
Light source warranty: 4 years or 20.000 hours

Colour wheel

9 dichroic filters (including one multicolour filter) + open

CMY colour mixing

Smooth CMY colour mixing system

Static gobo wheel

9 metal gobos

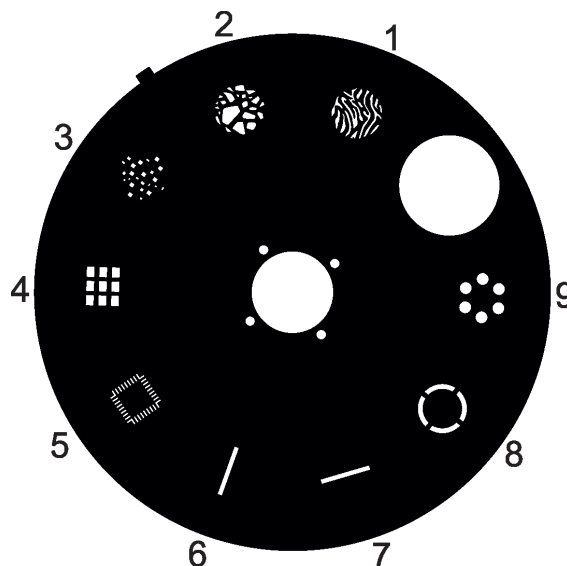

Rotating gobo wheel

8 glass gobos can be indexed and rotated in both directions at different speeds
Gobo wheel continuous rotation
Glass gobos: outside diameter= 15.8^{+0,15} mm, image diameter=12.5 mm, thickness=1.1-1.5 mm,
high temperature borofloat or better glass
"Slot&lock" system for easy replacement of gobos

Gobos order:

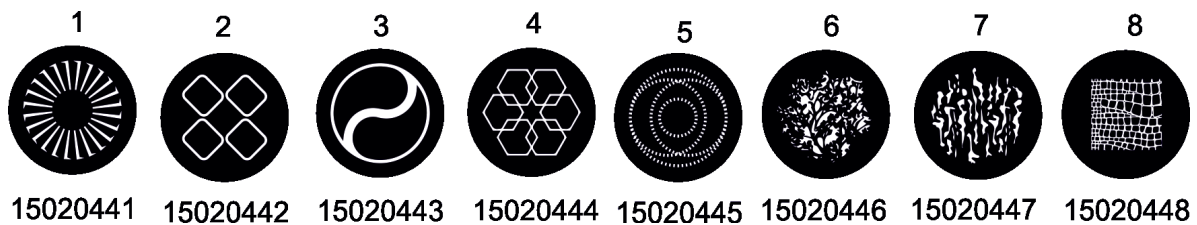

Prism

8-facet rotating prism with continuous rotation in both directions

Frost filter

Frost filter 5° installed

Zoom

Motorized zoom 8° - 48°

Focus

Motorized focus allows to focus beam from approx. 2 meters to infinity.

Framing shutters module

4 individually positionable shutters rotation of the complete frame system +/- 60°
Each framing shutter can be swiveled

Strobe

Strobe effect with variable speed (0.3 - 20Hz)

Dimmer

Smooth dimmer from 0 - 100 %

Pan/Tilt

Pan movement range 540°
Tilt movement range 270°
16 bit movement resolution
Automatic Pan/Tilt position correction
Pan/Tilt electronic motion stabilizer
Remotely controllable speed of pan/tilt

Control

Graphic touch screen for fixture setting and addressing
Gravitation sensor for auto screen positioning
Battery backup of the touch screen
Readout fixture usage, receiving DMX values, temperatures, etc
Built-in analyzer for easy fault finding, error messages
Silent fans cooling,
Stand-alone operation
3 user editable programs, each up to 40 steps
Supported protocols: USITT DMX 512, RDM, RDMnet, ArtNet, MA Net, MA Net2, sACN
2 DMX mode (44/45 control channels)

Wireless DMX/RDM module type RW 001

Supported protocols: full RDM support, CRMX , W-DMX™ G2, G3,G4 and G4S
Operational frequency range: 2402-2480 MHz
Output power: 100 mW
Receiver sensitivity (0.1% BER): -93 dBm
Crystal Clock Frequency : 16.0 MHz

Max. number of fixtures in Ethernet IN/Out line

8

Connection

DMX data in/out: 2 x IP65 Locking 5-pin XLR connector Seetronic

Ethernet: 2 x IP65 RJ45 connector Seetronic

Power: IP65 power connector Seetronic

Rigging

Mounting points: 2 pairs of 1/4-turn locks

Mounting horizontally or vertically via two Omega holders

Temperatures

Minimum/Maximum ambient operating temperature : -30°C/+45°C

Maximum housing temperature : 80° C

Distances

Min. distance from flammable surfaces: 0.5 m

Min. distance to lit object: 3 m

Total heat dissipation

max. 1126 BTU/h (calculated)

Ingress protection rating

IP65

Weight

25.5 kg (56.2 lbs)

Dimensions (mm)

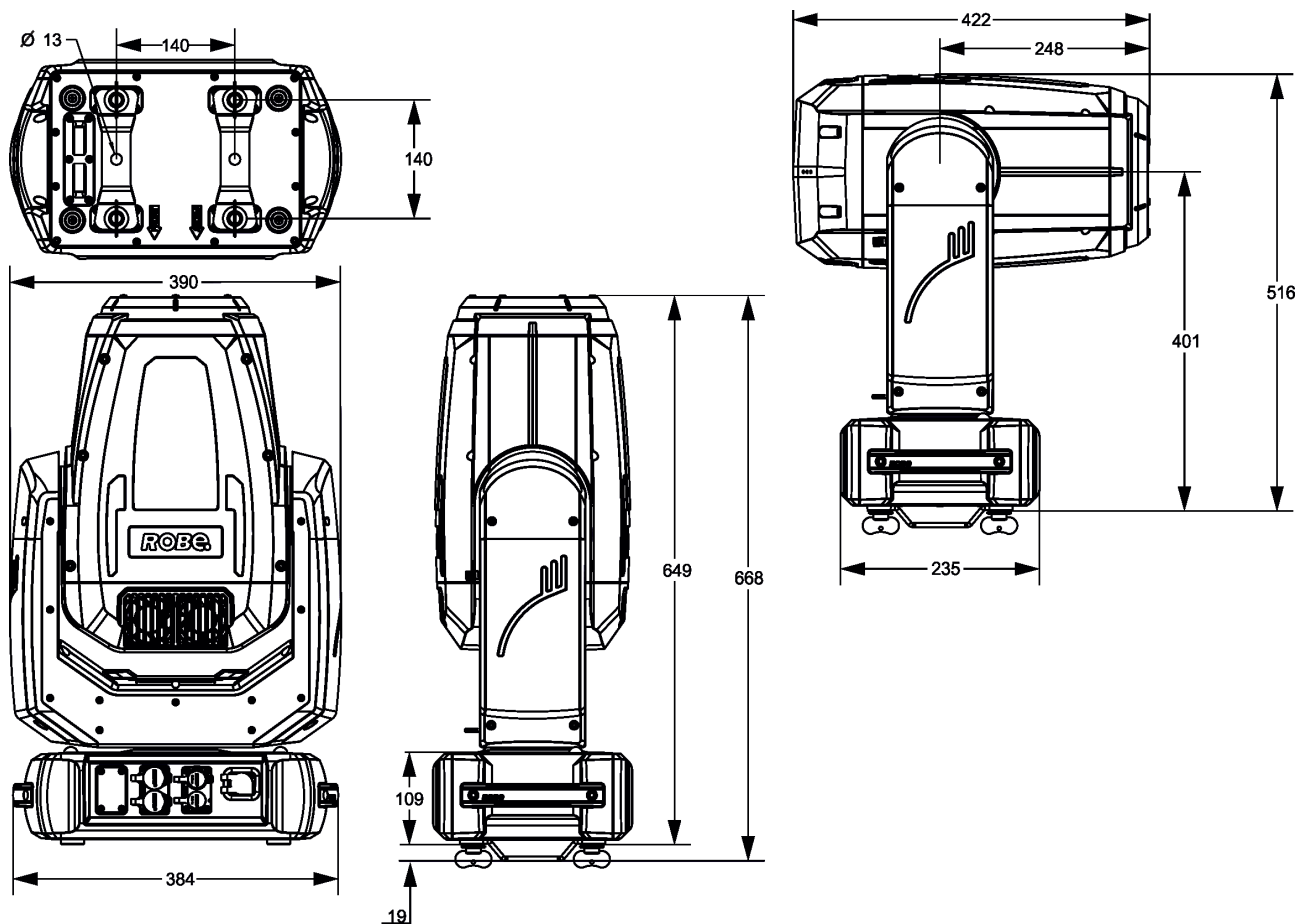

Desiccants

Total weight of all silica gel fillings in the fixture is 96 g

Accessories

1 x Omega adaptor CL-regular 2 pcs in box (P/N 10980033)
1 x Power cable including powerCON TRUE1 In connector

Optional accessories

(P/N 10980690) Frost 0.5° (exchange) assembled
(P/N 10980691) Frost 1° (exchange) assembled
(P/N 10980758) Frost 3,5° (exchange) assembled
(P/N 10980693) Frost 10° (exchange) assembled
(P/N 10980694) Frost 20° (exchange) assembled
(P/N 109806915) Frost 30° (exchange) assembled
(P/N 10980033) Omega Adaptor CL-regular 2 pcs
(P/N 17030386) Doughty Trigger Clamp
(P/N 99011963) Safety wire 36 kg
(P/N 14080084) iPAINTE TE-iSE™ 310W HP White LED Engine
(P/N 14080085) iPAINTE TE-iSE™ 310W HCF White LED Engine
(P/N 10981139) Framing module for iPainte (99017786 Module Framing Shutters iPainte)
(P/N 10981140) Open gate module for iPainte (99018098 Module iri iPainte)

18. ChangeLog

This section summarizes changes in the user manual.

Version of the manual	Date of issue	Description of changes
1.1	09/11/2023	Gobo change procedure modified
1.2	11/12/2023	RDMnet, intensity drop signalization and QR code on display
1.3	19/02/2024	POI version added
1.4	03/07/2024	Silica gel weight added to tech. spec.
1.5	08/11/2024	P/N 10981139 Framing module for iPainte added to specifications P/N 10981140 Open gate module for iPainte added to specifications

November 11, 2024

Copyright © 2022-2024 Robe Lighting - All rights reserved

All Specifications subject to change without notice

Made in CZECH REPUBLIC by ROBE LIGHTING s.r.o. Palackeho 416/20 CZ 75701 Valasske Mezirici



DMX protocol

iPainte® - DMX protocol				
Version 1.1 Standard 16 bit, Mode 2 -enhanced gobo control				
Mode/Total channels		DMX Value	Function	Type of control
1/44	2/45			
1	1	0 - 255	Pan Pan movement by 540° (128=default)	proportional
2	2	0 - 255	Pan Fine Fine control of pan movement (0=default)	proportional
3	3	0 - 255	Tilt Tilt movement by 270° (128=default)	proportional
4	4	0 - 255	Tilt fine Fine control of tilt movement (0=default)	proportional
5	5		Pan/Tilt speed , Pan/Tilt time	
		0	Standard mode (0=default)	step
		1	Max. Speed Mode	step
			Pan/Tilt speed mode	
		2 - 255	Speed from max. to min.	proportional
		Pan/Tilt time mode		
		2 - 255	Time from 0.2 s to 25.5 sec.	proportional
6	6		Power/Special functions	
		0 -5	Reserved (0=default) <i>To activate following functions, stop in DMX value for at least 3 s and shutter must be closed at least 3 sec. („Shutter,Strobe“ channel 42/43 must be at range: 0-31 DMX). Corresponding menu items are temporarily overridden.</i>	
		6-7	Standby mode: On (fixture effects are deactivated, light output is closed)	step
		8-9	Standby mode: Off	step
		10-14	DMX input: Wired DMX *	step
		15-19	DMX input: Wireless DMX *	step
			* function is active only 10 seconds after switching the fixture on	
		20-24	Graphic display: On	step
		25-29	Graphic display: Off	step
		30-31	Quiet mode: Fans On at blackout	step
		32-33	Quiet mode: Fans Off at blackout	step
		34-35	Dimmer curve: Super Square Law	step
		36-37	Pressure test: On (fixture does not respond to DMX during the test except values 36-37 (Pressure test Off))	step
		38-39	Pressure test: Off	step
		40-44	Pan/Tilt mode: Speed	step
		45-49	Pan/Tilt mode: Time	step
		50-54	Blackout while pan/tilt moving: On	step
		55-59	Blackout while pan/tilt moving: Off	step
		60-64	Blackout while gobo wheel moving: On	step
		65-69	Blackout while gobo wheel moving: Off	step
70-74	Blackout while colour wheel moving: On	step		
75-79	Blackout while colour wheel moving: Off	step		
80-84	Fans mode: Auto	step		
85-89	Fans mode: High	step		
		90-99	Reserved	

DMX protocol

Mode/Total channels		DMX Value	Function	Type of control
1/44	2/45			
		100-104	Focus Tracking: On	step
		105-109	Focus Tracking: Off	step
		110-114	Dimmer curve: Square law	step
		115-119	Dimmer curve: Linear	step
		120-124	Parking position: On	step
		125-129	Parking position: Off	step
			<i>To activate following functions, stop in DMX value for at least 3 seconds.</i>	
		130 - 139	Total fixture reset (without pan/tilt)	step
		140 - 149	Pan and Tilt reset	step
		150 - 159	Colour system reset	step
		160 - 169	Gobo wheels reset	step
		170-174	Pan reset	step
		175-179	Tilt reset	step
		180 - 189	Zoom/focus/frost/prism reset	step
		190 - 199	Iris /framing shutters reset	step
		200 - 209	Total fixture reset (including pan/tilt)	step
		210 - 218	Reserved	
			The following three commands define transition from gobo rotation to gobo indexing:	
		219 - 220	Gobo indexing: Maximum speed and shortcut	step
		221 - 222	Gobo indexing: Follow speed and direction	step
		223 - 224	Gobo indexing: Maximum speed and follow direction	step
			The following RoboSpot related commands are only applicable when the RoboSpot is connected:	
		225 - 229	RoboSpot enabled	step
		230 - 234	RoboSpot disabled - except handle faders and pan/tilt	step
		235 - 239	RoboSpot fully disabled	step
		240	Disabled "Quiet mode"	step
		241 - 255	Quiet mode - fan noise control from min. to max.	proportional
7	7		LED frequency selection	
			Factory display menu setting: 600Hz	
			<i>Select PWM output frequency of LEDs. Selected PWM frequency can be fine adjusted in 127 steps up/down around selected PWM frequency on the channel below. Corresponding menu item is temporarily overridden.</i>	
		0-4	PWM frequency from Display menu (fixture utilizes PWM frequency set in the display menu item Frequency Setup).	step
		5-9	300 Hz	step
		10-14	600 Hz (10=default)	step
		15-19	1200 Hz	step
		20-24	2400 Hz	step
		25-29	High	step
		30-255	Reserved (fixture utilizes PWM frequency set in the display menu item Frequency Setup).	
8	8		LED frequency fine adjusting	
			Factory display menu setting: 600Hz	
			<i>Select desired PWM output frequency of LEDs on the channel above.</i>	
		0-1	Selected LED Frequency	step

DMX protocol

Mode/Total channels		DMX Value	Function	Type of control
1/44	2/45			
		2	LED Frequency (step -126)	step
		3	LED Frequency (step -125)	step
		4	LED Frequency (step -124)	step
		:		
		125	LED Frequency (step -3)	step
		126	LED Frequency (step -2)	step
		127	LED Frequency (step -1)	step
		128	Selected LED Frequency (128=default)	step
		129	LED Frequency (step +1)	step
		130	LED Frequency (step +2)	step
		131	LED Frequency (step +3)	step
		:		
		252	LED Frequency (step +124)	step
		253	LED Frequency (step +125)	step
		254	LED Frequency (step +126)	step
		255	Selected LED Frequency	step
9	9		Max. light intensity indication and setting	
		0-10	No function (0=default)	
		11-20	Indication of drop of max. light intensity	step
			<p><i>A drop of max. light intensity of the fixture (compared to its original intensity) is indicated by a corresponding colour output:</i></p> <p><i>0-5%, (WHITE /new LED module/)</i></p> <p><i>6-10% (RED)</i></p> <p><i>11-15% (GREEN)</i></p> <p><i>16-20% (BLUE)</i></p> <p><i>21-25% (CYAN)</i></p> <p><i>26-30% (MAGENTA)</i></p> <p><i>31-35% (YELLOW)</i></p> <p><i>36-40% (ORANGE)</i></p> <p><i>Pan/tilt is set at 128 DMX (50%), Dimmer is open at 255 DMX (100%).</i></p> <p><i>To set a drop of max. light intensity (compared to original light intensity), stay at DMX value for at least 3 sec. and shutter must be closed at least 3 sec. (Channel „Shutter/Strobe“ 42/43 must be at range: 0-31 DMX). Corresponding menu items are permanently overwritten.</i></p>	
		21-30	Set drop by 6-10% (RED)	step
		31-40	Set drop by 11-15% (GREEN)	step
		41-50	Drop by 16-20% (BLUE)	step
		51-60	Set drop by 21-25% (CYAN)	step
		61-70	Set drop by 26-30% (MAGENTA)	step
		71-80	Set drop by 31-35% (YELLOW)	step
		81-90	Set drop by 36-40% (ORANGE)	step
		91-100	Original intensity (WHITE)	step
		101-255	Reserved	
10	10		Colour wheel	
			Continual positioning	
		0	Open/white	proportional

DMX protocol

Mode/Total channels		DMX Value	Function	Type of control
1/44	2/45			
		12	Deep red	proportional
		25	Deep blue	proportional
		39	Light green	proportional
		51	Lavender	proportional
		64	Orange	proportional
		77	Multicolor	proportional
		90	Filter CRI 90	proportional
		103	CTO 3200K	proportional
		115	Congo blue	proportional
		128-129	White	step
			Positioning	
		130-136	Deep red	step
		137-142	Deep blue	step
		143-149	Light green	step
		150-155	Lavender	step
		156-162	Orange	step
		163-168	Multicolor	step
		169-175	Filter CRI 90	step
		176-182	CTO 3200K	step
		183-189	Congo blue	step
		190 - 215	Forwards rainbow effect from fast to slow	proportional
		216 - 217	No rotation	step
		218 - 243	Backwards rainbow effect from slow to fast	proportional
		244 - 249	Reserved	
		250 - 255	Auto random colour selection from fast to slow	proportional
11	11		Colour wheel - fine positioning	
		0 - 255	Fine positioning (0=default)	proportional
12	12		Cyan	
		0 - 255	Cyan from min. saturation --> full cyan (0=default)	proportional
13	13		Magenta	
		0 - 255	Magenta from min. saturation --> full magenta (0=default)	proportional
14	14		Yellow	
		0 - 255	Yellow from min. saturation --> full yellow (0=default)	proportional
15	15		Virtual CTO	
		0-255	Colour temperature change from 6700K --> 2700K (0=default)	proportional
16	16		Green correction	
		0	Uncorrected white	step
		1-127	Minus green --> uncorrected white	proportional
		128	Uncorrected white (128=default)	step
		129-255	Uncorrected white --> Plus green	proportional
17	17		Virtual colour wheel	
			<i>See table "Colours on Virtual Colour Wheel" to find components of each colour</i>	
			<i>The following channels are disabled: 9-16</i>	
		0	No function (0=default)	step
		1-2	Filter 4 (Medium Bastard Amber)	step
		3-4	Filter 10 (Medium Yellow)	step
		5-6	Filter 19 (Fire)	step

DMX protocol

Mode/Total channels		DMX Value	Function	Type of control
1/44	2/45			
		7-8	Filter 26 (Bright Red)	step
		9-10	Filter 58 (Lavender)	step
		11-12	Filter 68 (Sky Blue)	step
		13-14	Filter 71 (Tokyo Blue)	step
		15-16	Filter 79 (Just Blue)	step
		17-18	Filter 88 (Lime Green)	step
		19-20	Filter 90 (Dark Yellow Green)	step
		21-22	Filter 100 (Spring Yellow)	step
		23-24	Filter 101 (Yellow)	step
		25-26	Filter 102 (Light Amber)	step
		27-28	Filter 103 (Straw)	step
		29-30	Filter 104 (Deep Amber)	step
		31-32	Filter 105 (Orange)	step
		33-34	Filter 106 (Primary Red)	step
		35-36	Filter 111 (Dark Pink)	step
		37-38	Filter 115 (Peacock Blue)	step
		39-40	Filter 116 (Medium Blue-Green)	step
		41-42	Filter 117 (Steel Blue)	step
		43-44	Filter 118 (Light Blue)	step
		45-46	Filter 119 (Dark Blue)	step
		47-48	Filter 120 (Deep Blue)	step
		49-50	Filter 121 (Filter Green)	step
		51-52	Filter 128 (Bright Pink)	step
		53-54	Filter 131 (Marine Blue)	step
		55-56	Filter 132 (Medium Blue)	step
		57-58	Filter 134 (Golden Amber)	step
		59-60	Filter 135 (Deep Golden Amber)	step
		61-62	Filter 136 (Pale Lavender)	step
		63-64	Filter 137 (Special Lavender)	step
		65-66	Filter 138 (Pale Green)	step
		67-68	Filter 139 (Primary Green)	step
		69-70	Filter 141 (Bright Blue)	step
		71-72	Filter 147 (Apricot)	step
		73-74	Filter 148 (Bright Rose)	step
		75-76	Filter 152 (Pale Gold)	step
		77-78	Filter 154 (Pale Rose)	step
		79-80	Filter 157 (Pink)	step
		81-82	Filter 158 (Deep Orange)	step
		83-84	Filter 162 (Bastard Amber)	step
		85-86	Filter 164 (Flame Red)	step
		87-88	Filter 165 (Daylight Blue)	step
		89-90	Filter 169 (Lilac Tint)	step
		91-92	Filter 170 (Deep Lavender)	step
		93-94	Filter 172 (Lagoon Blue)	step
		95-96	Filter 179 (Chrome Orange)	step
		97-98	Filter 180 (Dark Lavender)	step
		99-100	Filter 181 (Congo Blue)	step
		101-102	Filter 197 (Alice Blue)	step

DMX protocol

Mode/Total channels		DMX Value	Function	Type of control
1/44	2/45			
		103-104	Filter 201 (Full C.T. Blue)	step
		105-106	Filter 202 (Half C.T. Blue)	step
		107-108	Filter 203 (Quarter C.T. Blue)	step
		109-110	Filter 204 (Full C.T. Orange)	step
		111-112	Filter 205 (Half C.T. Orange)	step
		113-114	Filter 206 (Quarter C.T. Orange)	step
		115-116	Filter 247 (Filter Minus Green)	step
		117-118	Filter 248 (Half Minus Green)	step
		119-120	Filter 281 (Three Quarter C.T. Blue)	step
		121-122	Filter 285 (Three Quarter C.T. Orange)	step
		123-124	Filter 352 (Glacier Blue)	step
		125-126	Filter 353 (Lighter Blue)	step
		127-128	Filter 715 (Cabana Blue)	step
		129-130	Filter 778 (Millennium Gold)	step
		131-132	Filter 793 (Vanity Fair)	step
		133-255	Reserved	
18	18		CMY and Colour wheel time	
		0	Function is off (0=default)	step
		1 - 255	Time of CMY and Colour wheel movement (0.1sec-->25.5sec.)	proportional
19	19		Framing shutters/Zoom/Focus/Frost/Iris/Prism time	
		0	Function is off (0=default)	step
		1 - 255	Time of framing shutters, zoom, focus, iris and frost movement (0.1 sec-->25.5 sec.)	proportional
		1-50	Time of prism movement (0.1 sec-->5 sec.)	proportional
20	20		Static gobo wheel	
		0-8	Open/hole	step
			<u>Positioning</u>	
		9-17	Gobo 1	step
		18-26	Gobo 2	step
		27-35	Gobo 3	step
		36-44	Gobo 4	step
		45-53	Gobo 5	step
		54-62	Gobo 6	step
		63-71	Gobo 7	step
		72-80	Gobo 8	step
		81-91	Gobo 9	step
			<u>Shaking gobos from slow to fast</u>	
		92-103	Gobo 1	proportional
		104-115	Gobo 2	proportional
		116-127	Gobo 3	proportional
		128-139	Gobo 4	proportional
		140-151	Gobo 5	proportional
		152-163	Gobo 6	proportional
		164-175	Gobo 7	proportional
		176-187	Gobo 8	proportional
		188-199	Gobo 9	proportional
		200-201	Open/hole	step
		202 - 222	Forwards gobo wheel rotation from fast to slow	proportional

DMX protocol

Mode/Total channels		DMX Value	Function	Type of control
1/44	2/45			
		223 - 243	Backwards gobo wheel rotation from slow to fast	proportional
		244 - 249	Reserved	
		250 - 255	<i>Auto random gobo selection from fast to slow</i>	proportional
21	*		Rotating gobo wheel	
			<i>Index - set indexing on channel 22</i>	
		0-9	Open/Hole (default)	step
		10-13	Gobo 1	step
		14-17	Gobo 2	step
		18-21	Gobo 3	step
		22-25	Gobo 4	step
		26-29	Gobo 5	step
		30-33	Gobo 6	step
		34-37	Gobo 7	step
		38-41	Gobo 8	step
			<i>Rotation - set rotation on channel 22</i>	
		42-45	Gobo 1	step
		46-49	Gobo 2	step
		50-53	Gobo 3	step
		54-57	Gobo 4	step
		58-61	Gobo 5	step
		62-65	Gobo 6	step
		66-69	Gobo 7	step
		70-73	Gobo 8	step
			<i>Shaking gobos from slow to fast</i>	
			<i>Index - set indexing on channel 22</i>	
		74-81	Gobo 1	proportional
		82-89	Gobo 2	proportional
		90-97	Gobo 3	proportional
		98-105	Gobo 4	proportional
		106-113	Gobo 5	proportional
		114-121	Gobo 6	proportional
		122-129	Gobo 7	proportional
		130-137	Gobo 8	proportional
			<i>Shaking gobos from slow to fast</i>	
			<i>Rotation - set rotation on channel 22</i>	
		138-145	Gobo 1	proportional
		146-153	Gobo 2	proportional
		154-161	Gobo 3	proportional
		162-169	Gobo 4	proportional
		170-177	Gobo 5	proportional
		178-185	Gobo 6	proportional
		186-192	Gobo 7	proportional
		193-199	Gobo 8	proportional
		200 - 201	Open/hole	step
		202 - 222	Forwards gobo wheel rotation from fast to slow	proportional
		223 - 243	Backwards gobo wheel rotation from slow to fast	proportional
		244 - 249	Reserved	
		250 - 255	Auto random gobo selection from fast to slow	proportional

DMX protocol

Mode/Total channels		DMX Value	Function	Type of control
1/44	2/45			
*	21		Rotating gobo wheel	
			<i>Index - set indexing on channel 23</i>	
		0-9	Open/Hole (default)	step
		10-13	Gobo 1	step
		14-17	Gobo 2	step
		18-21	Gobo 3	step
		22-25	Gobo 4	step
		26-29	Gobo 5	step
		30-33	Gobo 6	step
		34-37	Gobo 7	step
		38-41	Gobo 8	step
			<i>Rotation - set rotation on channel 23</i>	
		42-45	Gobo 1	step
		46-49	Gobo 2	step
		50-53	Gobo 3	step
		54-57	Gobo 4	step
		58-61	Gobo 5	step
		62-65	Gobo 6	step
		66-69	Gobo 7	step
		70-73	Gobo 8	step
			Continual positioning	
			<i>Index - set indexing on channel 23</i>	
		74	Open/hole	proportional
		81	Gobo 1	proportional
		88	Gobo 2	proportional
		95	Gobo 3	proportional
		102	Gobo 4	proportional
		109	Gobo 5	proportional
		116	Gobo 6	proportional
		123	Gobo 7	proportional
		130	Gobo 8	proportional
		137	Open/hole	proportional
			Continual positioning	
			<i>Rotation - set rotation on channel 23</i>	
		138	Open/hole	proportional
		145	Gobo 1	proportional
		152	Gobo 2	proportional
		159	Gobo 3	proportional
		166	Gobo 4	proportional
		173	Gobo 5	proportional
		180	Gobo 6	proportional
		187	Gobo 7	proportional
		194	Gobo 8	proportional
		201	Open/hole	proportional
		202 - 222	Forwards gobo wheel rotation from fast to slow	proportional
		223 - 243	Backwards gobo wheel rotation from slow to fast	proportional
		244 - 249	Reserved	
		250 - 255	Auto random gobo selection from fast to slow	proportional

DMX protocol

Mode/Total channels		DMX Value	Function	Type of control
1/44	2/45			
*	22		Rotating gobo wheel - fine positioning	
		0 - 255	Fine positioning (0=default)	proportional
22	23		Rot. Gobo indexing/rotation	
			Gobo indexing - set position on channel 21	
		0 - 255	Gobo indexing (128=default)	proportional
			Gobo rotation - set position on channel 21	
		0	No rotation	step
		1 - 127	Forwards gobo rotation from fast to slow	proportional
		128	No rotation (128=default)	step
		129 - 255	Backwards gobo rotation from slow to fast	proportional
23	24		Rot. Gobo indexing/rotation - fine	
		0-255	Fine indexing/rotation (0=default)	proportional
24	25		Prism	
		0 - 19	Open position/hole (0=default)	step
		20 - 73	Prism indexing	step
		74-127	Prism rotation	step
			Prism/gobo macros	
			<i>The following channels are blocked: Rotating gobo wheel, Rot. Gobo indexing and rotation, Rot. Gobo wheel fine rotation</i>	
		128 - 135	Macro 1	step
		136 - 143	Macro 2	step
		144 - 151	Macro 3	step
		152 - 159	Macro 4	step
		160 - 167	Macro 5	step
		168 - 175	Macro 6	step
		176 - 183	Macro 7	step
		184 - 191	Macro 8	step
		192 - 199	Macro 9	step
		200 - 207	Macro 10	step
		208 - 215	Macro 11	step
		216 - 223	Macro 12	step
		224 - 231	Macro 13	step
		232 - 239	Macro 14	step
		240 - 247	Macro 15	step
		248 - 255	Macro 16	step
25	26		Prism indexing/rotation	
			Prism indexing - set position on channel 24/25	
		0 - 255	Prism 1 indexing	proportional
			Prism rotation - set position on channel 24/25	
		0	No rotation	step
		1 - 127	Forwards prism rotation from fast to slow	proportional
		128	No rotation (128=default)	step
		129-255	Backwards prism rotation from slow to fast	proportional
26	27		Frost	
			Frost cannot stay in intermediate position, it will auto-move to full/open position.	
		0	Open (0=default)	step
		1 - 179	Frost from 0% to 100%	proportional

DMX protocol

Mode/Total channels		DMX Value	Function	Type of control
1/44	2/45			
		180 - 189	100% frost	step
		190 - 211	Pulse closing from slow to fast	proportional
		212 - 233	Pulse opening from fast to slow	proportional
		234 - 255	Ramping from fast to slow	proportional
27	28		Iris	
		0	Open (0=default)	step
		1 - 179	From max. diameter to min. diameter	proportional
		180 - 191	Closed	step
			Pulse effects with Iris blackout	
		192 - 219	Pulse opening from slow to fast	proportional
		220 - 247	Pulse closing from fast to slow	proportional
		248 - 249	Random pulse opening (fast)	step
		250 - 251	Random pulse opening (slow)	step
		252 - 253	Random pulse closing (fast)	step
		254 - 255	Random pulse closing (slow)	step
28	29		Iris - fine	
		0 - 255	Fine iris movement (0=default)	proportional
29	30		Zoom	
		0 - 255	Zoom from max. to min. beam angle (128=default)	proportional
30	31		Zoom - fine	
		0-255	Fine zooming (0=default)	proportional
31	32		Focus	
		0 - 255	Continuous adjustment from far to near (128=default)	proportional
32	33		Focus - fine	
		0- 255	Fine focusing (0=default)	proportional
33	34		Framing shutters module rotation	
		0-127	Rotation from right (0°) to 60°	proportional
		128	Centre (128=default)	step
		129-255	Rotation from 60° to left (120°)	proportional
34	35		Framing shutter 1- movement	
		0-255	Movement from Outward to Inward (0=default)	proportional
35	36		Framing shutter 1- swivelling	
		0-127	Swivelling from -30 degrees towards 0 degrees	proportional
		128	0 degrees (128=default)	step
		129-255	Swivelling from 0 degrees to +30 degrees	proportional
36	37		Framing shutter 2- movement	
		0-255	Movement from Outward to Inward (0=default)	proportional
37	38		Framing shutter 2- swivelling	
		0-127	Swivelling from -30 degrees towards 0 degrees	proportional
		128	0 degrees (128=default)	step
		129-255	Swivelling from 0 degrees to +30 degrees	proportional
38	39		Framing shutter 3 movement	
		0-255	Movement from Outward to Inward (0=default)	proportional
39	40		Framing shutter 3- swivelling	
		0-127	Swivelling from -30 degrees towards 0 degrees	proportional
		128	0 degrees (128=default)	step
		129-255	Swivelling from 0 degrees to +30 degrees	proportional
40	41		Framing shutter 4 movement	

DMX protocol

Mode/ <i>Total channels</i>		DMX Value	Function	Type of control
1/44	2/45			
		0-255	Movement from Outward to Inward (0=default)	proportional
41	42		Framing shutter 4- swivelling	
		0-127	Swivelling from -30 degrees towards 0 degrees	proportional
		128	0 degrees (128=default)	step
		129-255	Swivelling from 0 degrees to +30 degrees	proportional
42	43		Shutter/ strobe	
		0 - 31	Shutter closed	step
		32 - 63	Shutter open (32=default)	step
		64 - 95	Strobe-effect from slow to fast	proportional
		96 - 127	Shutter open	step
		128 - 143	Opening pulse in sequences from slow to fast	proportional
		144 - 159	Closing pulse in sequences from fast to slow	proportional
		160 - 191	Shutter open	proportional
		192 - 223	Random strobe-effect from slow to fast	proportional
		224 - 255	Shutter open	step
43	44		Dimmer intensity	
		0 - 255	Dimmer intensity from 0% to 100% (0=default)	proportional
44	45		Dimmer intensity - fine	
		0 - 255	Fine dimming (0=default)	proportional
Copyright © 2023 Robe Lighting s.r.o. - All rights reserved				
All Specifications subject to change without notice				

Robin iPainte® - colours on Virtual Colour Wheel				
Colour name	Cyan (DMX)	Magenta (DMX)	Yellow (DMX)	Colour Wheel (DMX)
Filter 4 (Medium Bastard Amber)	0	165	180	0
Filter 10 (Medium Yellow)	0	149	228	0
Filter 19 (Fire)	0	247	255	0
Filter 24 (Scarlet)	0	0	0	134
Filter 58 (Lavender)	0	197	97	0
Filter 68 (Sky Blue)	169	0	0	154
Filter 71 (Tokyo Blue)	0	0	0	142
Filter 79 (Just Blue)	201	172	0	0
Filter 88 (Lime Green)	127	0	214	0
Filter 90 (Dark Yellow Green)	230	0	224	0
Filter 100 (Spring Yellow)	0	117	223	0
Filter 101 (Yellow)	0	153	223	0
Filter 102 (Light Amber)	0	151	192	0
Filter 103 (Straw)	0	135	185	0
Filter 104 (Deep Amber)	0	172	233	0
Filter 105 (Orange)	0	195	242	0
Filter 781 (Terry Red)	0	248	0	161
Filter 111 (Dark Pink)	0	197	189	0
Filter 115 (Peacock Blue)	252	0	181	0
Filter 505 (Sally Green)	251	0	189	0
Filter 117 (Steel Blue)	177	0	146	0
Filter 118 (Light Blue)	235	0	157	0
Filter 724 (Ocean Blue)	255	58	0	0
Filter 725 (Old Steel Blue)	255	115	0	0
Filter 121 (Filter Green)	192	0	255	0
Filter 128 (Bright Pink)	0	231	177	0
Filter 131 (Marine Blue)	219	0	127	0
Filter 132 (Medium Blue)	255	0	57	0
Filter 134 (Golden Amber)	0	191	255	0
Filter 135 (Deep Golden Amber)	0	222	255	0
Filter 136 (Pale Lavender)	0	184	121	0
Filter 137 (Special Lavender)	0	141	110	0
Filter 138 (Pale Green)	115	0	182	0
Filter 139 (Primary Green)	243	0	236	0
Filter 141 (Bright Blue)	255	0	114	0
Filter 147 (Apricot)	0	177	222	0
Filter 148 (Bright Rose)	0	220	203	0
Filter 152 (Pale Gold)	0	173	189	0
Filter 154 (Pale Rose)	0	170	173	0
Filter 157 (Pink)	0	214	212	0
Filter 158 (Deep Orange)	0	216	254	0
Filter 162 (Bastard Amber)	0	150	183	0
Filter 164 (Flame Red)	0	255	255	0
Filter 165 (Daylight Blue)	217	0	12	0
Filter 169 (Lilac Tint)	0	183	143	0
Filter 170 (Deep Lavender)	38	183	104	0

Colour name	Cyan (DMX)	Magenta (DMX)	Yellow (DMX)	Colour Wheel (DMX)
Filter 172 (Lagoon Blue)	234	0	121	0
Filter 179 (Chrome Orange)	0	177	248	0
Filter 180 (Dark Lavender)	179	174	0	0
Filter 181 (Congo Blue)	189	207	0	0
Filter 197 (Alice Blue)	255	140	0	0
Filter 201 (Full C.T. Blue)	179	0	99	0
Filter 202 (Half C.T. Blue)	168	0	81	0
Filter 203 (Quarter C.T. Blue)	151	0	136	0
Filter 204 (Full C.T. Orange)	0	186	243	0
Filter 205 (Half C.T. Orange)	0	160	193	0
Filter 206 (Quarter C.T. Orange)	0	155	157	0
Filter 247 (Filter Minus Green)	0	176	123	0
Filter 248 (Half Minus Green)	0	114	111	0
Filter 281 (Three Quarter C.T. Blue)	179	0	117	0
Filter 285 (Three Quarter C.T. Orange)	0	166	232	0
Filter 352 (Glacier Blue)	221	0	98	0
Filter 353 (Lighter Blue)	237	0	140	0
Filter 715 (Cabana Blue)	255	120	0	0
Filter 778 (Millennium Gold)	0	210	255	0
Filter 328 (Follies Pink)	0	231	159	0
Robin Painte®/Painte® Spot - CTO DMX values				
Colour temperature (K)	DMX value			
	HP module			
2700	255			
2800	249			
3000	236			
3200	228			
3600	206			
4000	183			
4500	159			
4800	135			
5000	113			
5600	72			
6000	47			
6500	0			
Note: zoom 128DMX				