

ROBE

TetraX™

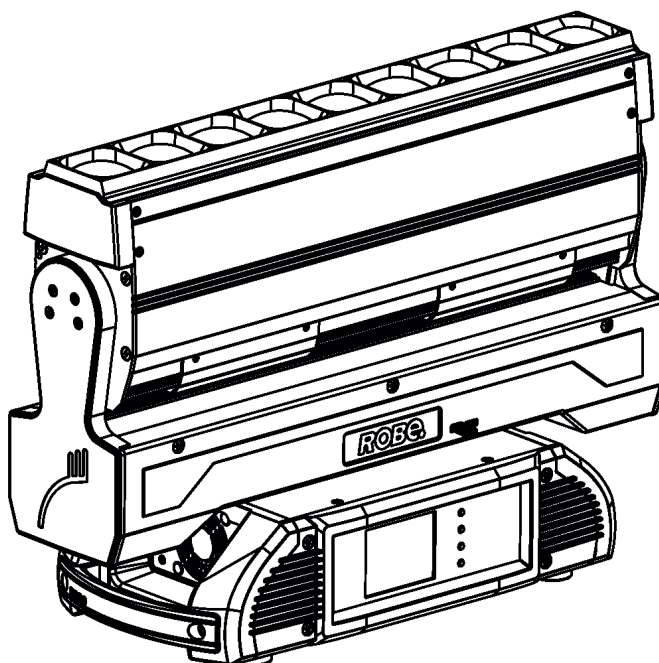

QR code for user manual



USER MANUAL

ROBE® lighting s.r.o. • Czech Republic • www.robe.cz

Version 1.4

TetraX

Table of contents

1. Safety instructions	3
2. Operating determination	5
3. Fixture exterior view	6
4. Installation	7
4.1 Connection to the mains	7
4.2 Rigging the fixture	8
4.3 DMX-512 connection.....	10
4.4 Ethernet connection	11
4.5 Wireless DMX operation	13
5. Remotely controllable functions	14
6. Control menu map	15
7. Control menu	18
7.1 Tab "Address"	19
7.2 Tab "Information"	20
7.3 Tab "Personality"	21
7.4 Tab "Manual Control".....	23
7.5 Tab "Stand-alone"	23
7.6 Tab "Service"	24
8. RDM	28
9. Robe Ethernet Access Portal (REAP)	28
10. Error and information messages	29
11. Technical Specifications	30
12. Maintenance and cleaning	31
12.1 Removing the optical module	34
12.2 Disposing of the product	36
13. ChangeLog	36
14. Appendix - DMX modes overview	37

CAUTION!

***Keep this device away from rain and moisture!
Unplug mains lead before opening the housing!***

**FOR YOUR OWN SAFETY, PLEASE READ THIS USER MANUAL CAREFULLY
BEFORE YOU INITIAL START - UP!**

1. Safety instructions

Every person involved with installation and maintenance of this device have to:

- be qualified
- follow the instructions of this manual

CAUTION!

***Disconnect the fixture from mains before you remove any cover of the fixture.
With a high voltage you can suffer a dangerous electric shock when touching
alive wires and electrical parts under covers!***

This device has left our premises in absolutely perfect condition. In order to maintain this condition and to ensure a safe operation, it is absolutely necessary for the user to follow the safety instructions and warning notes written in this manual.

The manufacturer will not accept liability for any resulting damages caused by the non-observance of this manual or any unauthorized modification to the device.

Please consider that damages caused by manual modifications to the device are not subject to warranty.

Make sure that the available voltage is not higher than stated on the bottom side of the fixture.

WARNING! This unit does not contain an ON/OFF switch. Always disconnect power input cable to completely remove power from unit when not in use or before cleaning or servicing the unit.

Make sure that the power cord is never crimped or damaged by sharp edges. Check the device and the power-cord from time to time.

Always disconnect from the mains, when the device is not in use or before cleaning it.

This device falls under protection class I. Therefore it is essential to connect the yellow/green conductor to earth.

The electric connection, repairs and servicing must be carried out by a qualified employee.

Do not connect this device to a dimmer pack.
For replacement use fuses of same type and rating only.

The fixture becomes hot during operation. Do not touch the device's housing bare hands during its operation. Allow the fixture to cool approximately 30 minutes prior to manipulate with it.

LED light emission. Risk of eye injury. Do not look into the beam at short distance of the of the product. Do not view the light output with optical instruments or any device that may concentrate the beam. The light source contains blue LEDs.

CAUTION! Risk group 2, RG-2



Prior to manipulate the fixture, lock its moving head in a horizontal position by means of the pan lock.

Be careful when the fixture performs fast pan rotation.
There is a danger of injury of your hands (especially fingers).

Danger of injury!

Danger area when: - pan continually rotates

- you touching the graphic screen (and the fixture is under voltage)
- you connect cables (and the fixture is under voltage)

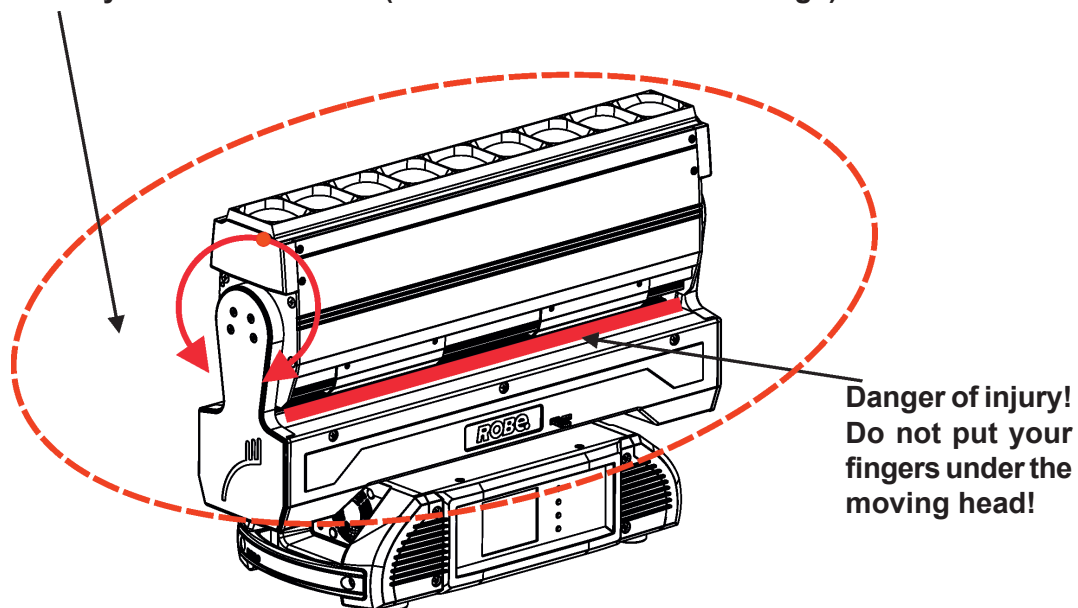

2. Operating determination

This device is a moving line for creating decorative effects and was designed for indoor use only.

This device is for professional use only. It is not for household use.

If the device has been exposed to drastic temperature fluctuation (e.g. after transportation), do not switch it on immediately. The arising condensation water might damage your device. Leave the device switched off until it has reached room temperature.

Avoid brute force when installing or operating the device.

When choosing the installation spot, please make sure that the device is not exposed to extreme heat, moisture or dust!

Make sure that the area below the installation place is blocked when rigging, de-rigging or servicing the fixture.

Always secure the fixture with an appropriate safety wire.

To avoid damage of an internal optical system of the fixture, never let the sunlight (or other light source) lights directly to the lens array, even when the fixture is not working

Please use the original packaging if the device is to be transported.

Please consider that unauthorized modifications on the device are forbidden due to safety reasons.

If this device will be operated in any way different to the one described in this manual, the product may suffer damages and the guarantee becomes void. Furthermore, any other operation may lead to dangers like short-circuit, burns, electric shock etc.

The product (covers and cables) must not be exposed to a high frequency electromagnetic field higher than 3V/m.

Immunity of the equipment is designed according to the standard EN 55035 Electromagnetic compatibility of multimedia equipment - Immunity requirements

Emission of the equipment complies with the standard EN55032 Electromagnetic compatibility of multimedia equipment – Emission Requirements according to class B.

Contains FCC ID: 2A6PL-DMXRDMRW001*

Contains IC: 29573-DMXRDMRW001*

* Wireless DMX version of the fixture only.

This device complies with part 15 of the FCC Rules. Operation is subject to the following two conditions: (1) This device may not cause harmful interference, and (2) this device must accept any interference received, including interference that may cause undesired operation.

Changes or modifications not expressly approved by the party responsible for compliance could void the user's authority to operate the equipment.

The [Device] wireless operation is safe and complies to RF Exposure requirements

This equipment has been tested and found to comply with the limits for a Class B digital device, pursuant to part 15 of the FCC Rules. These limits are designed to provide reasonable protection against harmful interference in a residential installation. This equipment generates, uses and can radiate radio frequency energy and, if not installed and used in accordance with the instructions, may cause harmful interference to radio communications. However, there is no guarantee that interference will not occur in a particular installation. If this equipment does cause harmful interference to radio or television reception, which can be determined by turning the equipment off and on, the user is encouraged to try to correct the interference by one or more of the following measures:

- Reorient or relocate the receiving antenna.
- Increase the separation between the equipment and receiver.
- Connect the equipment into an outlet on a circuit different from that to which the receiver is connected.
- Consult the dealer or an experienced radio/TV technician for help.

3. Fixture exterior view

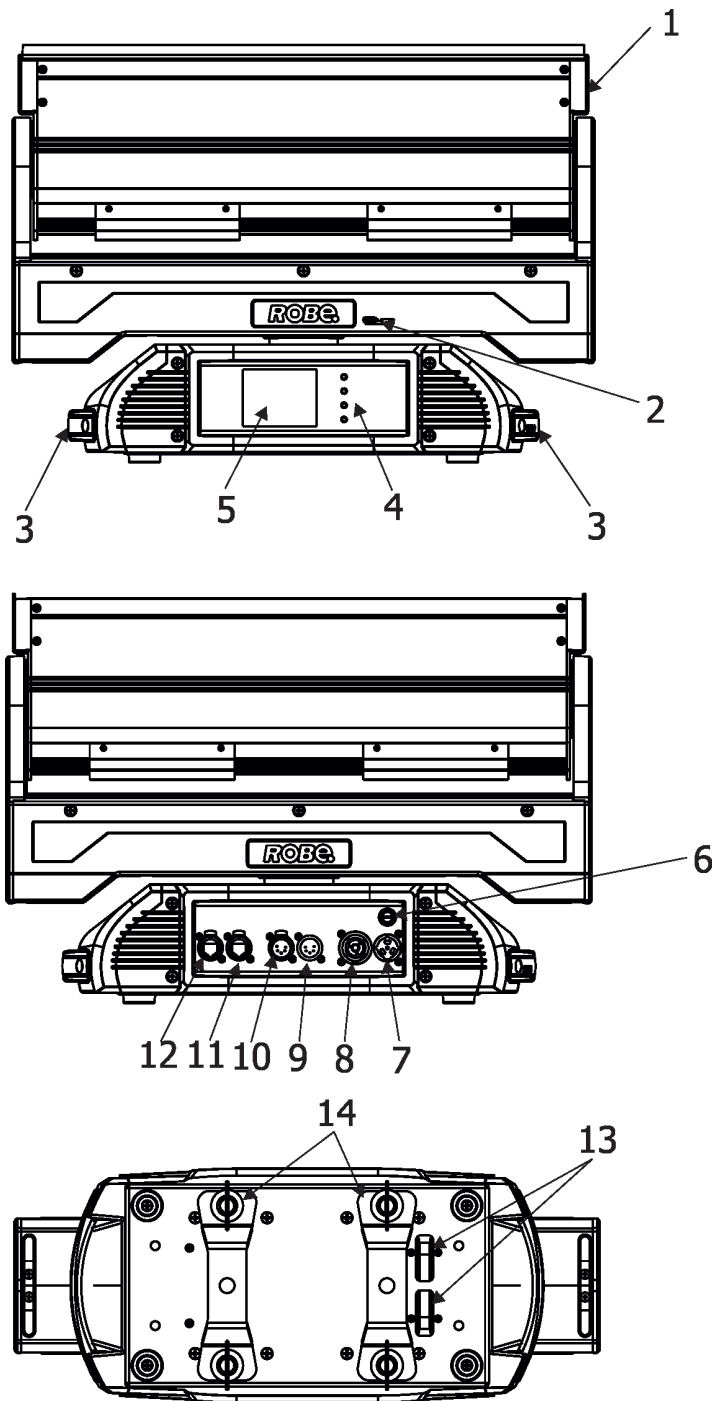

- | | |
|--------------------------------|---------------------------------------|
| 1 - Moving head | 8 - Power OUT (PowerCon True 1) |
| 2 - Pan lock | 9 - DMX IN (5-pin XLR) |
| 3 - Holders | 10 - DMX OUT (5-pin XLR) |
| 4 - Control buttons | 11 - Ethernet IN |
| 5 - QVGA touch screen | 12 - Ethernet OUT |
| 6 - Fuse holder | 13 - Attachment point for safety wire |
| 7 - Power IN (PowerCon True 1) | 14 - Omega holders |

The head has to be locked for transportation - the pan lock latch (2) has to be in the locked position. To unlock the head, move the latch to unlock position before operating the fixture.

4. Installation



Fixtures must be installed by a qualified electrician in accordance with all national and local electrical and construction codes and regulations.

4.1 Connection to the mains

For protection from electric shock, the fixture must be earthed!

The Robin TetraX is equipped with auto-switching power supply that automatically adjusts to any 50-60Hz AC power source from 100-240 Volts.

If you install a cord cap on the power cable to allow connection to power outlets, install a grounding-type (earthed) plug, following the plug manufacturer's instructions.

The cores in the power cable are coloured according to the following table.

Core (EU)	Core (US)	Connection	Plug Terminal Marking
Brown	Black	Live	L
Light blue	White	Neutral	N
Yellow/Green	Green	Earth	

This device falls under class one and must be earthed (grounded)!

To apply power, first check that the tilt locks is released.

Design of the ROBIN TetraX allows to connect several fixtures to AC mains power in one interconnected daisy chain using power input and throughput connectors. Needed daisy chain cords are stated in the chapter "Technical specifications "

Maximum number of linked fixtures depends on input voltage:

CE:

11 fixtures at power supply= 230V

10 fixtures at power supply= 208V

5 fixtures at power supply= 120V

US:

9 fixtures at power supply= 230V

8 fixtures at power supply= 208V

4 fixtures at power supply= 120V

Real numbers of fixtures may differ from values stated above as you have to take into account the length of supply cables, circuit breaker etc. at projecting of the fixtures installation Do not overload the supply line and connecting leads.

4.2 Rigging the fixture

A structure intended for installation of the fixture (s) must safely hold weight of the fixture(s) placed on it. The structure has to be certificated to the purpose.

The fixture (fixtures) must be installed in accordance with national and local electrical and construction codes and regulations.

For overhead installation, the fixture must be always secured with a safety wire that can bear at least 10 times the weight of the fixture.

When rigging, derigging or servicing the fixture staying in the area below the installation place, on bridges, under high working places and other endangered areas is forbidden.

The operator has to make sure that safety-relating and machine-technical installations are approved by an expert before taking into operation for the first time and after changes before taking into operation another time.

The operator has to make sure that safety-relating and machine-technical installations are approved by a skilled person once a year.

Allow the fixture to cool for 30 minutes before handling.

IMPORTANT! OVERHEAD RIGGING REQUIRES EXTENSIVE EXPERIENCE, including calculating working load limits, installation material being used, and periodic safety inspection of all installation material and the projector. If you lack these qualifications, do not attempt the installation yourself, but use a help of professional companies.

CAUTION: Fixtures may cause severe injuries when crashing down! If you have doubts concerning the safety of a possible installation, do not install the fixture!

The fixture has to be installed out of the reach of public.

The fixture must never be fixed swinging freely in the room.

Danger of fire !
When installing the device, make sure there is no highly inflammable material (decoration articles, etc.) in a distance of min. 0.5 m.

CAUTION!
Use 2 appropriate clamps to rig the fixture on the truss.
Make sure that the device is fixed properly!
Ensure that the structure (truss) to which you are attaching the fixtures is secure.

The fixture can be placed directly on the stage floor or rigged in any orientation on a truss without altering its operation characteristics .

For securing the fixture to the truss, install a safety wire which can hold at least 10 times the weight of the fixture. Use only the safety wire with a snap hook with screw lock gate.

Truss installation

1. Bolt rigging clamps (1) to the omega holders (2) with M12 bolts and lock nuts through the holes in the holders.
2. Fasten the omega holders to the bottom of the base by inserting both quick-lock fasteners (3) into the holes of the base and tighten fully them clockwise.
3. Clamp the fixture on the truss (4) and tighten the rigging clamps.
4. Pull one safety wire (5) around the truss (4) and through the handle (7) and lock the snap hook with screw lock gate in the attachment point (6).

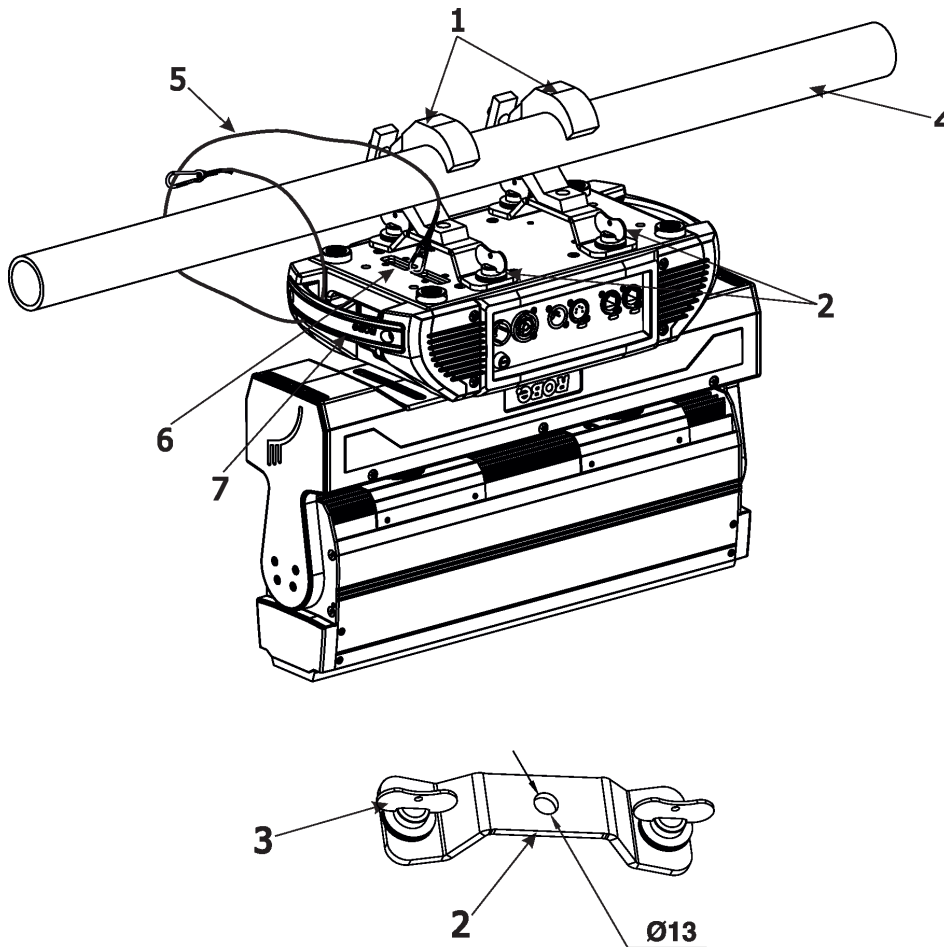

Avoid illuminating one fixture with another!

In order to protect the internal parts of the head from the sun, the function PARKING POSITION must be switched ON before switching the fixture off.

The PARKING POSITION function is located on the Power/Special functions channel (120-129 DMX). If the function is on, the fixture will automatically detect via G-sensor whether the fixture is on the floor or hangs on the truss and tilts the moving head to the position in which the moving head will always face down. Owing this position of the moving head, there is not chance to burn internal parts of the LEDs array by the sun light.

4.3 DMX-512 connection

The fixture is equipped with 5-pin XLR sockets for DMX input and output.

Only use a shielded twisted-pair cable designed for RS-485 and 5-pin XLR-plugs and connectors in order to connect the controller with the fixture or one fixture with another.

DMX output

XLR socket:



DMX input

XLRplug:



Building a serial DMX-chain.

Connect the DMX output of the first fixture in the DMX chain with the DMX input of the next fixture. Always connect one output with the input of the next fixture until all fixtures are connected. Up to 32 fixtures can be connected.

Caution: At the last fixture, the DMX cable has to be terminated with a terminator. Solder a 120 Ω resistor between Signal (-) and Signal (+) into a 5-pin XLR plug and plug it in the DMX output of the last fixture.

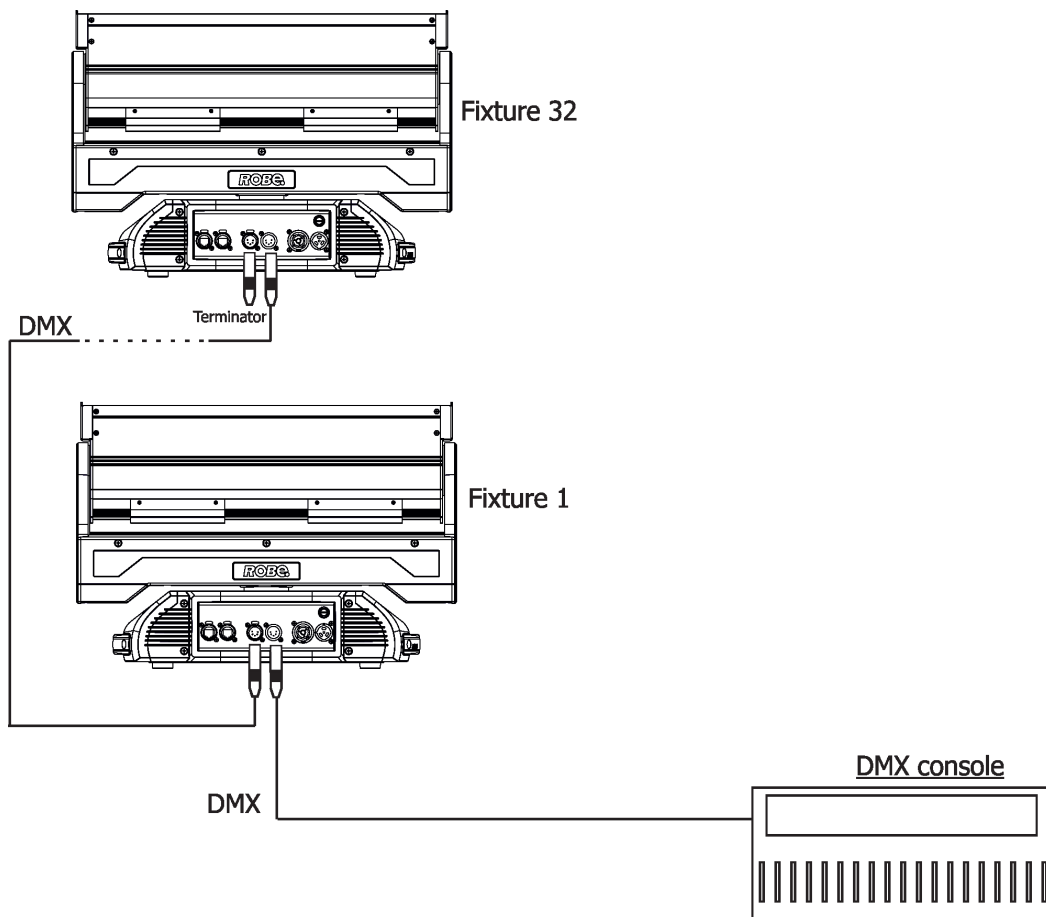

4.4 Ethernet connection

The fixtures on a data link are connected to the Ethernet with appropriate communication protocol (e.g. Art-Net). The control software running on your PC (or light console) has to support Art-Net protocol.

Art-Net communication protocol is a 10 Base T Ethernet protocol based on the TCP/IP. Its purpose is to allow transfer of large amounts of DMX 512 data over a wide area using standard network technology.

IP address is the Internet protocol address. The IP uniquely identifies any node (fixture) on a network.

The Universe is a single DMX 512 frame of 512 channels.

The Robin TetraX EP is equipped with 8-pin RJ-45 sockets for Ethernet connection. Use a network cable category 5 (with four “twisted” wire pairs) and standard RJ-45 plugs in order to connect the fixture to the network.

RJ-45 socket (front view):

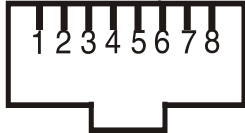

- | | |
|------------------|------------------|
| 1- TD+ | 5- Not connected |
| 2- TD- | 6- RX- |
| 3- RX+ | 7- Not connected |
| 4- Not connected | 8- Not connected |

RJ-45 plug (front view):

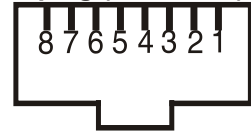

Patch cables that connect fixtures to the hubs or LAN sockets are wired 1:1, that is, pins with the same numbers are connected together:



If only the fixture and the computer are to be interconnected, no hubs or other active components are needed. A cross-cable has to be used:



If the fixture is connected with active Ethernet socket (e.g. switch) the network icon  will appear at the bottom right corner of the screen:

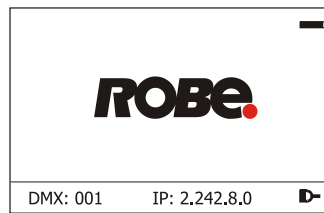

Ethernet operation

Connect the Ethernet inputs of all fixtures with the Ethernet network.

Option “Artnet (gMal or gMA2 or sACN)” has to be selected from “Ethernet Mode” menu on the fixture.

Set IP address (002.xxx.xxx.xxx / 010.xxx.xxx.xxx) and the Universe.

Example of connection:

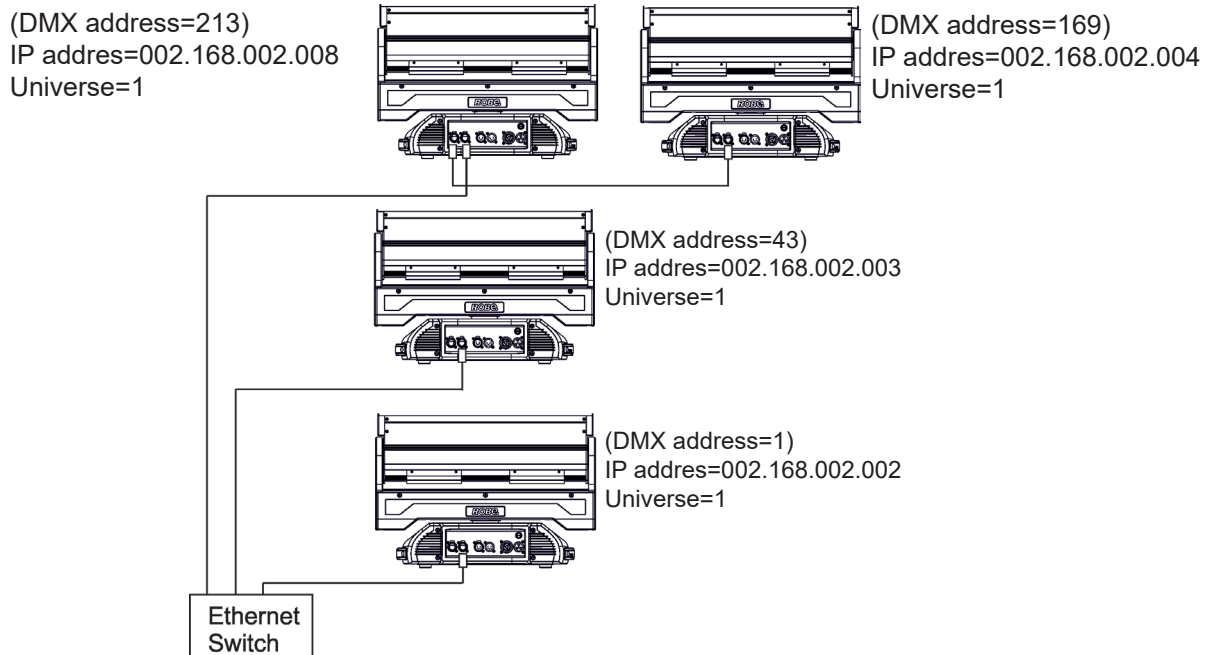

An advised PC setting: IP address: 002.xxx.xxx.xxx / 010.xxx.xxx.xxx (Different from fixture IP addresses)
NET mask: 255.0.0.0

The fixture is equipped with Ethernet Pass Through Switch which sustains Ethernet integrity, when the fixture has no power, it automatically maintains network connectivity.

If you use the Ethernet IN-OUT way for the Ethernet connection, max. 8 fixtures can be connected in the IN-OUT line.

Ethernet / DMX operation

Option "Ethernet to DMX" has to be selected from the "Ethernet Settings" menu on the first fixture (connected to the Ethernet) in the fixture chain, next fixtures have standard DMX setting.

Connect the Ethernet input of the first fixture in the data chain with the network. Connect the DMX output of this fixture with the input of the next fixture until all fixtures are connected to the DMX chain.

Caution: At the last fixture, the DMX chain has to be terminated with a terminator. Solder a 120 Ω resistor between Signal (-) and Signal (+) into a XLR plug and connect it in the DMX output of the last fixture.

Example:

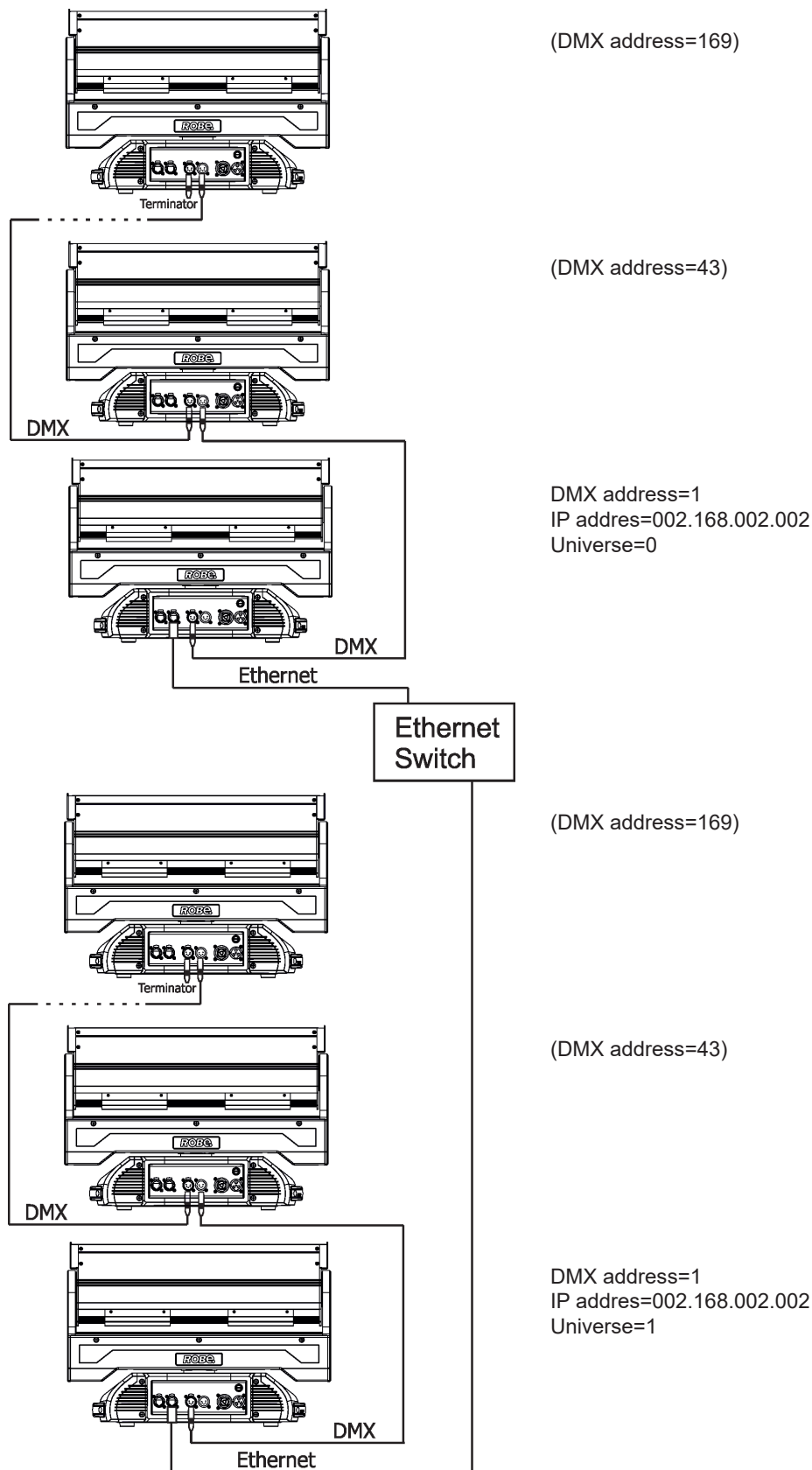

4.5 Wireless DMX operation

The wireless DMX version of the fixture is equipped with ROBE wireless DMX/RDM module, The module has full support for wireless communication protocols at entertainment market. Modul is based on well known LumenRadio RF technology, with implemented wire interface for connection with Robe products. RF output for MCX interface antenna as standard output.

The item " Wireless " from the menu "DMX Input" allows you to activate receiving of wireless DMX (Personality--> DMX Input -->Wireless.). First two options from the "DMX Input" menu are stated in DMX chart as well (channel Power/Special functions , range of 10-19 DMX). If DMX input option is changed by DMX command, the change is permanently written into fixture's memory.

DMX range of 10-19 switching fixture to the wired/wireless operation is active only during first 10 seconds after switching the fixture on.

After switching the fixture on, the fixture checks both modes of receiving DMX in the following order:

1. For the first five seconds, the fixture receives DMX signal from the wired input. If the Power/Special functions channel is set at some DMX input option, the fixture will receive DMX value according to this option. If DMX input option is set to the wired input , this option is saved and checking procedure is finished. If DMX input option is not set, the fixture continues next 5 seconds in scanning wireless DMX signal-see point 2.

2. For the next 5 seconds the fixture receives wireless DMX signal and again detects if the Power/Special functions channel is set at some DMX input option, if not, the fixture will take option which is set in the fixture menu "DMX Input".

To link the fixture with DMX transmitter.

The fixture can be only linked with the transmitter by running the link procedure at DMX transmitter .

After linking , the level of DMX signal (0-100 %) is displayed in the menu item "Wireless State" (Information -->Wireless State).

To unlink the fixture from DMX transmitter.

The fixture can be unlinked from receiver via the menu item " Unlink Wireless Adapter" (Information--> Wireless State --> Unlink Wireless Adaptor).

Note: If the option "Wireless In/XLR Out" is selected (Personality--> DMX Input -->Wireless In/XLR Out), the fixture receives wireless DMX and sends the signal to its wired DMX output. The fixture behaves as " Wireless/Wired" adaptor.

Example of connection:

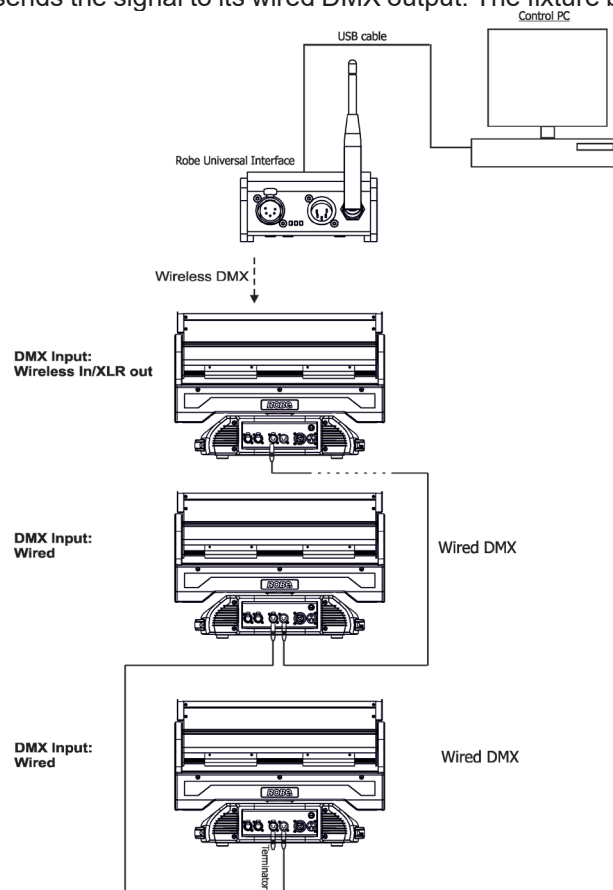

5. Remotely controllable functions

Virtual colour wheel

This wheel contains 66 preset colours, rainbow effect with/without fade time.

Colour temperature correction (CTC)

This channel allows to set calibrated white colour from range of 8000K-2700K.

RGBW or CMY colour mixing system

The RGBW colour mixing system is based on red, green, blue and white high power LEDs. Option for switching the fixture to the CMY colour mixing system is also available.

Colour Mix control

The Colour Mix control channel defines relation between global colours (RGBW, CTC, Virtual colour wheel) and individual RGB pixels or Kling-Net.

Global = Global Colours (RGBW, CTC, Virtual Colour Wheel)

Pixel = Pixel Colors (RGB individual pixels or Kling-Net)

DMX value	Function
0-9	Global colours (Global has priority)
10-19	Maximum mode (highest values have priority)
20-29	Minimum mode (lowest values have priority)
30-39	Multiply mode (multiply Global and Pixel)
40-49	Addition mode (Global + Pixel) - default
50-59	Subtraction mode (Global – Pixel)
60-69	Inverted Subtraction mode (Pixel – Global)
70-79	Coloured background
80-127	Reserved
128	Global colours (Global has priority)
129-254	Crossfade (crossfade between Global and Pixel)
255	Pixel colours (Pixel has priority)

E.g. If you wish to control RGBW channels, set the Colour Mix Control channel to 0 DMX, if you need to use pixel effects, set the Colour Mix Control channel to 255 DMX.

Multi-Coloured Flower Effects

Three Multi-Coloured Flower Effects rotating in both directions at variable speed create spectacular multicolour beam effects in the air.

Zoom

Motorized zoom offers beam range of 4° - 45°.

Pixel control

9 RGB pixels allow you to create many effects or use pre-defined pixel effects.

Dimmer/Shutter unit

Imperceptible 18 bit dimming 0 - 100 % for ultra smooth fade to black Strobe effects with variable speed.

Pan/Tilt

Precise pan/tilt movement in range of 540/191°.

Direction of pan/tilt movement and pixel order:

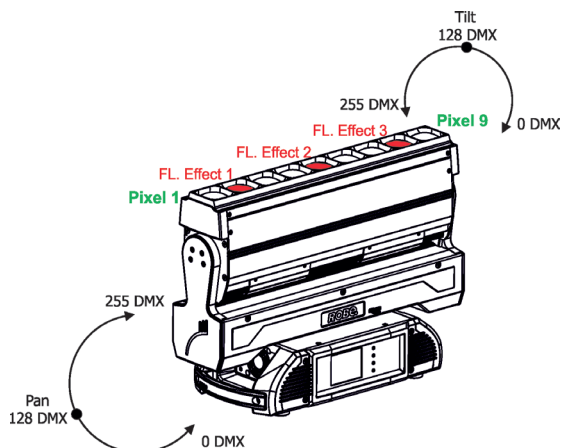





Multi-coloured flower effects are placed at pixel positions 2, 5, 8.

6. Control menu map

Default settings=**Bold print**

Tab	Level 1	Level 2	Level 3	Level 4	Level 5	Level 6	
Addressing	Settings	DMX Address	001-512				
		DMX Preset	Mode 1 , Mode 2, Mode 3, Mode 4 Mode 5, Mode 6				
		Ethernet Settings	Ethernet Mode	Disable			
				ArtNet			
				gMA1			
				gMA2			
				sACN			
				Ethernet To DMX	Off , On		
				IP Address/Net Mask	Default IP Address		
					Custom IP Address		
					Net Mask		
				ArtNet Universe	0-255		
				MANet settings	MANet/II Universe	01-256	
					MANet Session ID	01-32	
				sACN Settings	sACN Universe	00001-32000	
					sACN Priority	0-255	
				Klingnet Settings	Disable		
					Enable		
	Information	Fixture Times	Power On Time	Total Hours			
				Resetable Hours			
		Air Filters	Elapsed Time				
			Alert Period	10-300			
		Fixture Temperatures	LEDs Temperature	Current			
				Maximum NonRes.			
				Maximum Res.			
			Base Temperature	Current			
				Maximum NonRes.			
				Maximum Res.			
		DMX Values	Pan				
			:				
			White Pixel 9				
		Wireless State	Signal Quality				
			Unlink Wireless Adapter				
		Power Channel State					
		Software Versions	Display System				
			Module M				
			Module DR				
			Module PX				
			Wireless				
	Product IDs	Mac Address					
		RDM UID					
		RDM Label					
	View Logs	Fixture Errors					
		Fixture States	Power On				
			Power Off				
		Fixture Position					
		Fixture Temperatures	LEDs Temperature				
			Base Temperature				

Tab	Level 1	Level 2	Level 3	Level 4	Level 5	Level 6
Personality						
	DMX Presets	Mode 1				
		Mode 2				
		:				
		Mode 6				
		View Selected Preset				
	DMX Input	Wired Input				
		Wireless Input				
		Wireless In/XLR Out				
	Pan/Tilt Settings	Pan Reverse	Off, On			
		Tilt Reverse	Off, On			
		Pan/Tilt Feedback	Off, On			
		Pan/Tilt mode	Time			
			Speed			
	Pixel Control	Pixel Index	0-8			
		Pixel Mirror	On, Off			
		Reset to default				
	Microphone Sensitivity	1-10-20				
	Blackout Settings	Blackout During M.C.	Off, On			
		Blackout while:	Pan/Tilt moving	Off, On		
	Colour Mixing Mode	RGBW				
		CMY				
	White Point 8000K	Off, On				
	Automatic white pixel	Off, On				
	Tungsten Eff. Sim.	Off				
		750W				
		1000W				
		1200W				
		2000W				
		2500W				
	Dimmer Curve	Linear				
		Square Law				
	LEDs Output Frequency	Standard High				
	LEDs Frequency Adjust	-6....0....+6				
	Init Effect Positions	Pan	0-255			
		:				
		Dimmer Fine	0-255			
	Screen Settings	Display Intensity	1-10			
		Screen Saver Delay	Off-10min.			
		Touchscreen Lock	Off-10min.			
		Recalibrate Touchscreen				
		Display Orientation	Normal			
			Inverted			
			Auto			
	Temperature Unit	°C, °F				
	Fan settings	Fan Mode	Auto			
			High			
			Quiet			
		Quiet-Blackout Fan Off	Off, On			
	Date & Time Settings					
	Default Settings					

Tab	Level 1	Level 2	Level 3	Level 4	Level 5	Level 6
Manual Control	Reset Functions	Total System reset				
		Pan/Tilt reset				
		Zoom Reset				
		Flower E. Reset				
	Manual Effect Control	Pan	0-255			
		:				
		White Pixel 9	0-255			
Stand -Alone	Test Sequences	Dynamic Mode				
		Static Mode	Pan, Tilt	0-255		
			Zoom	0-255		
	MusicTrigger	Off, On				
	Preset Playback	None				
		Test				
		Prog. 1				
		Prog. 2				
		Prog. 3				
	Play Program	Play Program 1				
		Play Program 2				
		Play Program 3				
	Edit Program	Edit Program 1	Start Step	1-88		
			End Step	1-88		
			Edit Program Steps	Step 1	Tilt	0-255
				:	:	
				:	Dimmer Fine	0-255
				:	Step Time	0-25.5 sec.
				Step 88	Tilt	0-255
					:	
					Dimmer Fine	0-255
					Step Time	0-25.5 sec.
Service	Adjust DMX Values	Pan	0-255			
		:				
		White Pixel 8	0-255			
	Calibrations	Calibrate Effects	Pan	0-255		
			Tilt	0-255		
			FE 1 Rotation	0-255		
			FE 2 Rotation	0-255		
			FE 3 Rotation	0-355		
		Calibrate colours	Red	0-255		
			Green	0-255		
			Blue	0-255		
			White	0-255		
			Red Intensity	0-255		
			Green Intensity	0-255		
			Blue Intensity	0-255		
			White intensity	0-255		
		Pixel Correction	Red 1	0-255		
			Green 1	0-255		
			Blue 1	0-255		
			White 1	0-255		
			:			
			Red 9	0-255		
			Green 9	0-255		
			Blue 9	0-255		
			White 9	0-255		
		Load Default Calibrations				
	Update Software					

7. Control menu

The Robin TetraX is equipped with the QVGA Robe touch screen with battery backup which allows you to set the fixture's behaviour according to your needs, obtain information on its operation, test its various parts and program it, if it has to be used in a stand-alone mode.

The fixture's menu can be controlled either by the control buttons or directly by touching the icon.

Control buttons on the front panel:

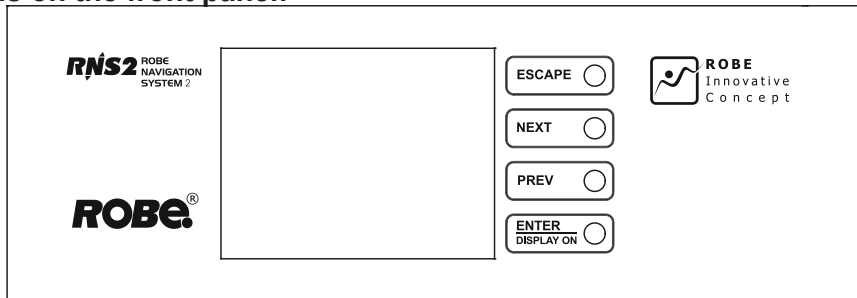

[ESCAPE] button used to leave the menu without saving changes.

[NEXT] , [PREV] buttons for moving between menu items and symbols, adjusting values.

[ENTER/Display On] button used to enter the selected menu (menu item) and to confirm adjusted value.

If the fixture is disconnected from mains, the button switches the touch screen on.

Icons used in the touch screen menu



- [back arrow] used to move back to the previous screen (menu).



- [up arrow] used to move up on the previous page.



- [down arrow] used to move down on the next page.



- [confirm] used to save adjusted values, to leave menu or to perform desired action.



- [cancel] used to leave menu item without saving changes.



- [confirm+copy] used to save adjusted values and copy them to the next prog. step.



- [warning icon] used to indicate some error which has occurred in the fixture.



- [Ethernet] used to indicate Ethernet connected.



- [display turn] used to turn the display by 180°.



- [slider control] used to recall slider system for setting desired value.



- [keyboard control] used to recall keyboard system for setting desired value.



- [air filters cleaning] used to signal that cleaning period of the air filters elapsed.

The menu page displays icons for each function that you can perform from the touch screen.

After switching the fixture on, the touch screen shows the screen with the ROBE logo:

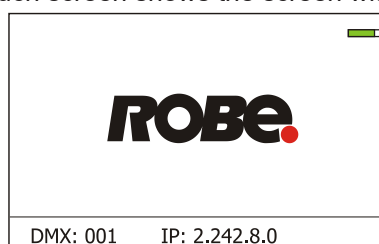

Note: The green icon at the top right corner of the screen indicates the level of the display battery charging. If the whole icon is green, the battery is fully charged while the red icon indicates exhausted battery. The battery charges during fixture operation, its charging lasts cca 6 hours.

We recommend that the fixture should be in operation at least 7 hours per week to keep the battery fully charged. If you switch the fixture on and this screen will not appear till 1 minute, switch the fixture off and on again. If the screen lights, the battery is exhausted. In case the screen still does not light, the battery is faulty.

This is also indicated by an error message "Faulty battery" and if such an error message appears the battery should be replaced immediately. The lifetime of the battery is highly dependent on ambient temperature (and consequently on base temperature). If the maximum ambient temperatures (as recorded and displayed in menu: Information -> Fixture Temperatures -> Ambient Temperature -> Maximum NonRes.) are kept within the specified limits, the battery should last for at least two years. Should the ambient temperatures exceed the specified maximum temperature, the lifetime of the batteries could be considerably shortened even up to just one year or less and also result in physical damage (battery leakage) or unreliable fixture functions.

Damage caused by batteries failed due to exceeded maximum ambient temperature cannot be claimed under warranty terms.

Touch any part of the screen or press the [ENTER/Display On] button to display the initial screen with the current stored DMX address:

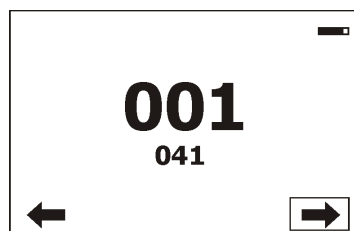

Touch the green arrow at the bottom right corner of the screen or press the [ENTER/Display On] button to enter the "Address" menu.

Each item (such as a Tab, menu item, text box, icon) may be selected from a screen by simply touching the item in the list or by pressing the [NEXT] or [PREV] buttons to scroll through items. With each press, the next item is highlighted. Press [ENTER/Display On] to select the highlighted item.

Before first fixture operation, set current date and time in the menu "Date & Time Settings" (menu path: Personality--> Date & Time Settings).

7.1 Tab "Address"



DMX Address - Select the menu to set the DMX start address.

Blinking DMX address means that the fixture is either not receiving DMX data or that the set DMX address is higher than allowed, exceeding the DMX footprint of the set DMX mode.

DMX Preset - Use the menu to select desired channel mode.

View Selected Preset - Use the menu to display channels included in the selected mode.

Ethernet Settings - The menu allows all needed settings for the Ethernet operation

Ethernet Mode

Disable - The option disables Ethernet operation.

Artnet - Fixture receives ArtNet protocol

gMA1 - Fixture receives MANet 1 protocol

gMA2 - Fixture receives MANet 2 protocol

sACN - Fixture receives sACN protocol

Ethernet To DMX - Fixture receives protocol from the Ethernet input and sends DMX data to its DMX output (fixture works as an "Ethernet/DMX converter", next fixture can be connected

to its DMX output and you can build a standard DMX chain by connecting another fixtures. Only one fixture has to be connected to the Ethernet.

IP Address/Net Mask - Select this menu to set IP address. IP address is the Internet protocol address. The IP uniquely identifies any node (fixture) on a network.

There cannot be 2 fixtures with the same IP address on the network!

Default IP Address -Preset IP address, you can set up only first byte of IP address (2 or 10) e.g. **002.019.052.086**.

Custom IP Address - The option enables to set up all bytes of IP address.

Net Mask - The option enables to set up all bytes of Net Mask.

ArtNet Universe - Use this item to set a Universe (0-255). The Universe is a single DMX 512 frame of 512 channels.

MANet Settings - Use this menu to set parameters for MANet operation.

MANet Universe I/II - The value of this item can be set in range 1-256.

MANet Session ID - The value of this item can be set in range 1-32.

sACN Settings - Use this menu to set parameters for sACN operation.

sACN Universe - The value of this item can be set in range 1-32000.

sACN Priority - The value of this item can be set in range 0-255.

Klingnet Settings - Use this menu to enable or disable Klingnet protocol.

7.2 Tab "Information"



Fixture Times - The menu provides readouts of fixture operation hours and air filters using hours.

Power On Time - Select this menu to read the number of fixture operation hours.

Total Hours - The item shows the total number of the operation hours since the Robin TetraX has been fabricated.

Resettable Hours - The item shows the number of the operation hours that the Robin TetraX has been powered on since the counter was last reset.

In order to reset this counter to 0, touch the text box next to the item "Resettable Hours:"

Air Filter - Regular cleaning of the air filter in the fixture base is very important for the fixture's life and performance.

The two items of this menu help you to keep cleaning period of the air filters.

Alert period - Cleaning schedule for the fixture depends on the operating environment.

It is therefore impossible to specify accurate cleaning interval. This item allows you to change the cleaning interval of the air filter. This "alert" value is 300 hours and it is set as default. Inspect the fixture within its 300 hours of operation to see whether cleaning is necessary. If cleaning is required, clean air filter and change the value in this menu on acceptable level. Min. level of alert period is 10 hours, max. is 300 hours.

Elapsed Time - The item allows you to read the time which remains to cleaning air filter.

The time period is set in the menu mentioned above.

Expired time period is signalled by a negative mark (-) at the time value and a warning icon on the display.

Clean the filter and reset this menu item (by touching the text box next to the item "Elapsed Time").

Fixture Temperatures - The menu is used to view temperatures of the fixture's inside.

LEDs temperature - The menu shows temperature on the LEDs PCB .

Current - A current temperature of the LEDs PCB.

Maximum NonRes. - A maximum temperature of the LEDs PCB since the fixture has been fabricated.

Maximum Res. - A maximum temperature of the LEDs PCB since the counter was last reset. In order to reset some counter to 0, touch desired text box under item "Max.Res."

Base Temperature - The menu shows temperature in the fixture base (on the display PCB).

Current - A current temperature in the fixture base.

Maximum NonRes. - A maximum temperature in the fixture base since the fixture has been fabricated.

Maximum Res. - A maximum temperature in the fixture base since the counter was last reset. In order to reset this counter to 0, touch the text box next to the item "Maximum Res."

DMX Values - The menu is used to read DMX values of each channel received by the fixture.

Wireless State - The menu serves for reading of the wireless operation status.

Unlink Wireless Adapter - The item serves for unlinking the fixture from DMX transmitter.

Power Channel State - The menu item shows state of the Power/Special functions switches.

Software Version - Select this item to read the software version of the fixture modules:

Display System - A display board in the fixture base

Module M - A pan/Tilt module

Module DR - A LEDs driver module

Module PX - Pixels + zoom control module

Wireless - Wireless DMX module

Product IDs - The menu is used to read the MAC Address ,RDM UID and RDM Label.

View Logs - Use this menu to read fixture's data which have been recorded during fixture operation. This collected data allows easier troubleshooting.

Fixture Errors - Use this menu to read fixture errors which have occurred during fixture operation.

Fixture States - Recorded following actions: Fixture On, Fixture Off.

Fixture Position - Recorded installation positions of the fixture:

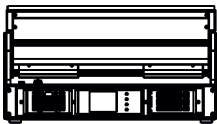

Front Normal

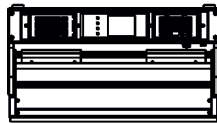

Front Inverted

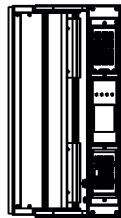

Side Top

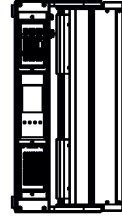

Side Bottom

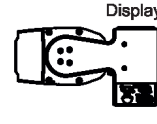

Top

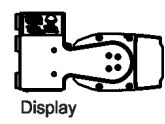

Bottom

Fixture Temperatures - Recorded temperatures which have exceeded defined levels.

Note: The log buffer can contain 8000 records max. If the buffer is full, old data will be overwritten.

7.3 Tab "Personality"



DMX Preset - Use the menu to select desired channel mode.

View Selected Preset - Use the menu to display channels included in the selected mode.

DMX Input - Use the menu to select mode of DMX signal receiving.

Wired - DMX signal is received by means of the standard DMX cable.

Wireless - DMX signal is received by means of the inbuilt wireless module.

Wireless In/XLR Out - the fixture receives wireless DMX and sends the signal to its wired DMX output.

The fixture behaves as "Wireless/Wired" adaptor.

The options "Wired" and "Wireless" are also stated in DMX chart (channel Power/Special functions).

Note. If the wireless module is not installed in the fixture, the following message will appear:

DMX Input Set to Wired

Wireless Module Missing

If the fixture is not connected to mains, the message "Not Available In Offline Mode" will appear after entering the menu DMX Input. To enter this menu, the fixture has to be connected to mains.

Pan/Tilt Settings - Use the menu set behaviour of the pan movement and the tilt movement.

Pan Reverse - The item allows to invert pan movement.

Tilt Reverse - The item allows to invert tilt movement.

Pan/Tilt Feedback - The item allows to return the mowing head to the required pan/tilt position after

changing the position by an external force if this option is set on.

Note. Be careful, the Pan/Tilt Feedback should be permanent On, the option Off is not suitable for standard operation and the head of the fixture can be damaged!

Pan/Tilt mode - Use this menu to set the mode of the pan/tilt movement

Time mode – The pan and tilt will move with different speeds and they will come at the same time to the end point of their tracks (pan and tilt use their optimal speeds). Time of the pan/tilt movement (25.5 sec. max.) is set by the channel "Pan/Tilt speed, Pan/Tilt time".

Speed Mode - Both Pan and tilt will move with the same speed as adjusted at the channel "Pan/Tilt speed, Pan/Tilt time".

Pixel Control - Use the menu to index or mirror pixels.

Pixel Index - The item allows you to choose needed position of turned pixels.

Pixel Mirror - The item allows mirroring of pixels along a vertical axis.

Both functions you can also find on the channel Power/Special functions (210-237 DMX).

Important: If you use DMX commands to set values for both Pixel Index and Pixel Mirror functions, set values will be lost after switching the fixture off. In order to save the values to the fixture, go to DMX value of 237 and stay in it for 3 sec. The set values will be saved to the fixture and will not be lost by switching the fixture off and on.

Reset to default - The item sets items "Pixel Index" and "Pixel Mirror" to default (factory) values.

Microphone Sensitivity - Enter the menu if you want to adjust the microphone sensitivity from 1 (max.) to 20 (min.).

Blackout Settings - Use the menu if you need to close the light output under certain conditions which are described below

Blackout DMC - Blackout during movement correction. Set this option On if you wish to close light output during the time when the LED module goes to its correct position, which has been changed by an external force.

Active Blackouts - Use this menu if you wish to close the light output during effect changes.

Tilt Moving - The menu item enables to close light output while the tilt is moving.

White Point 8000K - If the function is on, the CTC channel allows to set desired white in range of 8000K-2700K (0 DMX=8000K, 255 DMX=2700K). Necessary condition is, that RGBW channels have to be set at the same DMX values, e.g. 255.

If this function is off, the range of whites is not uniform and may be different for each fixture.

Automatic white pixel On/Off - In pixel control DMX modes, this function allows automatic activation of the white LEDs, based on levels of RGB pixels.

Colour Mixing Mode - This item allows switching into RGBW or CMY mode. In the CMY mode, the white(8bit)/white (16) bit channels are not active.

Tungsten Effect Sim. - This function simulates behaviour of a halogen lamp during dimming at calibrated whites 2700K, 3200K. You can select from various lamp wattage simulation: 750W, 1000W, 1200W, 2000W, 2500W.

Dimmer Curve - You can select desired dimmer curve: Linear or Square Law.

LEDs Output Frequency - The function allows you to set the PWM (Pulse Width Modulation) output frequency of LEDs to Standard (300Hz) or High (600Hz).

LEDs Frequency Adjust - The function allows you to change the selected PWM output frequency of LEDs in 6 levels up and down around the selected frequency in the menu "LEDs Output Frequency".

-1...-6 - Frequency levels 1 - 6 under selected frequency.

00 - Selected frequency (Standard or High)

1...6 - Frequency levels 1 - 6 above selected frequency.

Init Effect Positions - Use the menu to set all effects to the desired positions at which they will stay after switching the fixture on without DMX signal connected.

Screen Settings - Use this menu to change the touch screen settings.

Display Intensity - The item allows to control the intensity of the screen (1-min., 10-max.).

Screen saver Delay - The item allows you to keep the screen on or to turn it off automatically after 1-10 minutes after last touch (or pressing any button on the control panel).

Touchscreen Lock - The item allows you to lock the screen after last touch (or pressing any button on the control panel). The time delay can be set in range of 1-10 minutes. To unlock the screen, press the [ENTER/Display On] button.

Recalibrate Touchscreen - The item starts calibration of the touchscreen. Follow the instructions on the screen.

Display Orientation - The menu allows to change display orientation.

Normal - Standard display orientation if the fixture is placed horizontally (e.g. on the ground).

Inverted - This function rotates menu 180 degrees from current orientation.

Auto - The option activates a gravitation sensor for automatic screen orientation.

Note: **Auto** option is set as default. You change the display orientation by touching the icon  on the display, an the option set in the "Display Orientation" menu is temporarily overridden.

Temperature unit - Use the menu item to change temperature unit from °C to °F.

Fan Settings - Use the menu to set fans operation mode.

Fan Mode - Use the menu to set the fixture fans to max. power mode (option "**High**") or to the auto-control mode (option "**Auto**"). The third option "**Quiet**" allows you to set desired fan noise. The light output of the fixture is reduced at low speeds of fans.

Quiet - Blackout Fan Off - The menu item allows you to stop all fans in the fixture (option "**On**") when its light output is closed (shutter in range of 0-31 DMX or dimmer in 0 DMX). The menu item does not influence fans in the "**High**" mode.

Date & Time Settings - Use this menu to set current date and time for the fixture log system (menu "View Logs"). Set this menu item before first fixture operation.

Reset Web Password - The menu item allows you to reset a password for access to the REAP (default password: 2479, user: robe).

Default Settings - The menu item allows to set all fixture parameters to the default (factory) values.

7.4 Tab "Manual Control"



Reset Functions - The menu allows to reset the fixture either per function modules or all modules together.

Total System Reset - The item resets all function modules.

Pan/Tilt Reset - The item resets pan and tilt.

Zoom Reset - The item resets a zoom system.

Flower E. Reset - The item resets Flower effects.

Manual Effect control - Use the menu to control all fixture channels by means of the control panel.

7.5 Tab "Stand-alone"



Test Sequences -Use the menu to run a program sequences without an external controller, which will show you some possibilities of using the Robin TetraX.

Dynamic Mode - This mode uses all Robin TetraX functions including tilt movement and therefore is good for a complete introduction of the fixture.

Static Mode - This mode is suitable for projections on the wall, ceiling or ground without any tilt movement. Adjust the tilt to desired position and start test sequences by touching the green ► icon.

Music Trigger - Use the item to activate the sound control of the running program via the built-in microphone.

Preset Playback - This menu allows you to select the program which will be played in a loop after switching the fixture on (the option is commonly used in a stand-alone operation without an external controller).

None - The option disables "Presetting playback" function.

Test - The option starts the test sequences.

Prog. 1 - The option starts user program No. 1.

Prog. 2 - The option starts user program No. 2.

Prog. 3 - The option starts user program No. 3.

Play program - Use the menu to run desired program in a loop.

Play Program 1 - The option starts user program No.1.

Play Program 2 - The option starts user program No. 2.

Play Program 3 - The option starts user program No. 3.

Edit Program - Use the menu to create or to edit desired program. The Robin TetraX offers 3 free programs, each up to 88 steps.

Edit Program 1 - The option allows to edit user program No.1.

Edit Program 2 - The option allows to edit user program No.2.

Edit Program 3 - The option allows to edit user program No.3

To edit program:

1. Touch the item which you want to edit ("Edit Program 1" - "Edit Program 3").

2. Touch the item "Edit Program Steps".

3. Touch the item "Step 1".

4. From the list of effects touch desired effect and set its value. Browse through the list by touching the [up arrow] and [down arrow] and set all desired effects.

An item "Step Time" (value of 0-25.5 sec.) is the time during which effects last in the current step

5. Save adjusted effects to the current step by touching the [confirm] or save and copy them to the following step by touching the [confirm+copy]. By touching the text box "Preview" next to the current program step you can view created scene.

6. Repeat the steps 4 and 5 for next program steps.

7. After editing desired program steps, adjust the length of the program by touching the text boxes "Start Step" and "End Step".

Meaning of the icons used in the "Edit Program" menu:

↓ - moves down on the next page

✓ - saves adjusted values and leaves menu

↑ - moves up on the previous page

✓+ - saves values to the current step and copy them to the following prog. step

✗ - leaves menu without saving values

7.6 Tab "Service"



Adjust DMX Values - The menu allows you to set all effects to desired positions before fine calibration of the effects .

Calibrations - This menu enables fine calibration of fixture effects and download default calibration values.

Calibrate Effects - The menu allows the fine adjustment of effects.

Pan - a pan position fine adjustment

Tilt - a tilt position fine adjustment

FE 1 Rotation - a flower effect 1 fine rotation

FE 2 Rotation - a flower effect 2 fine rotation

FE 3 Rotation - a flower effect 3 fine rotation

Calibration of the effects via the control board

1. Disconnect DMX controller from the fixture and enter the "Calibrate Effects" menu.

2. Use the [up arrow] and [down arrow] to find "Tilt" and touch it to enter the fine effect adjustment screen.

3. Set desired value and save it by touching the [confirm].

4. Repeat steps 2 and 3 for next items.

5. After calibrating all effects, touch the [confirm] to save all adjusted values and reset the fixture.

Calibrate Colours - The menu serves for adjusting of LEDs saturation to achieve uniform colours

The items **Red, Green, Blue** and **White** serve for adjustment of white 5600K.

Calibration of white colour 5600K via the control board:

1. Disconnect DMX controller from the fixture , open shutter and dimmer and set the CTC channel to DMX=64 (white 5600K), RGBW channels to 255 DMX and Zoom channel to 128 DMX.

2. Set the following items in the menu Personality:
White Point 8000K =On
Colour Mixing Mode=RGBW
3. Aim the light beam on the lux meter (e.g. Minolta CL-500A Chroma meter) which is placed at min. distance of 3 m from the fixture.
4. Enter the menu Calibrate Colours.
5. By means of the Red, green, Blue and White items adjust the 5600K colour temperature as exactly as possible ($\Delta u'v' = 0$).
6. After adjusting 5600K colour temperature, touch the [confirm] to save all adjusted values and reset the fixture.

The items **Red Intensity**, **Green Intensity**, **Blue Intensity** and **White Intensity** serve for correction of intensity of red, green, blue and white colour on desired level (during fixture calibration in the factory).

Pixel Correction - The menu serves for colour calibration of fixture pixels in order to get uniform colours all over pixels.

Note: User can do the calibration of white 5600K only, other colour calibrations should be done in the factory.

Calibration protocol:

Effect	Mode 1	Mode 2	Mode 3	Mode 4	Mode 5
Pan - fine adjustment	channel 43	channel 63	channel 77	channel 86	channel 90
Tilt - fine adjustment	channel 44	channel 64	channel 78	channel 87	channel 91
FE 1 Rotation	channel 45	channel 65	channel 79	channel 88	channel 92
FE 2 Rotation	channel 46	channel 66	channel 80	channel 89	channel 93
FE 3 Rotation	channel 47	channel 67	channel 81	channel 90	channel 94
Red - red saturation	channel 48	channel 68	channel 82	channel 91	channel 95
Green- green saturation	channel 49	channel 69	channel 83	channel 92	channel 96
Blue - blue saturation	channel 50	channel 70	channel 84	channel 93	channel 97
White - white saturation	channel 51	channel 71	channel 85	channel 94	channel 98

Load Default Calibrations - The item loads default (factory) calibration values.

Update software - The menu item allows you to update software in the fixture via either serial or USB port of PC.

The following items are required in order to update software:

- PC running Windows or Linux or macOS
- DSU file
- or Robe Universal Interface / Robe Universal interface WTX.

To update software in the fixture:

1. DSU file is available from Robe web site at WWW.robe.cz.
File with extension zip is intended for Windows (used and tested from XP to W10 on 32/64bit systems).
File with extension tbz is intended for Linux (used and tested on Debian and Ubuntu 32/64bit).
File with extension dmg is intended for macOS (used and tested on OSX up to Sierra) XQuartz required, install it from <https://www.xquartz.org/>
Save the download file to a folder on your computer.
In case that you use windows, extract files in the zip file (e.g. DSU_RobinTetraX_18051835.zip)
2. Disconnect the fixture from DMX controller.
3. Connect a USB port of your computer with the Robe Universal Interface by means of the USB cable and DMX input of the fixture with the DMX output of the Robe Universal Interface via a DMX cable.

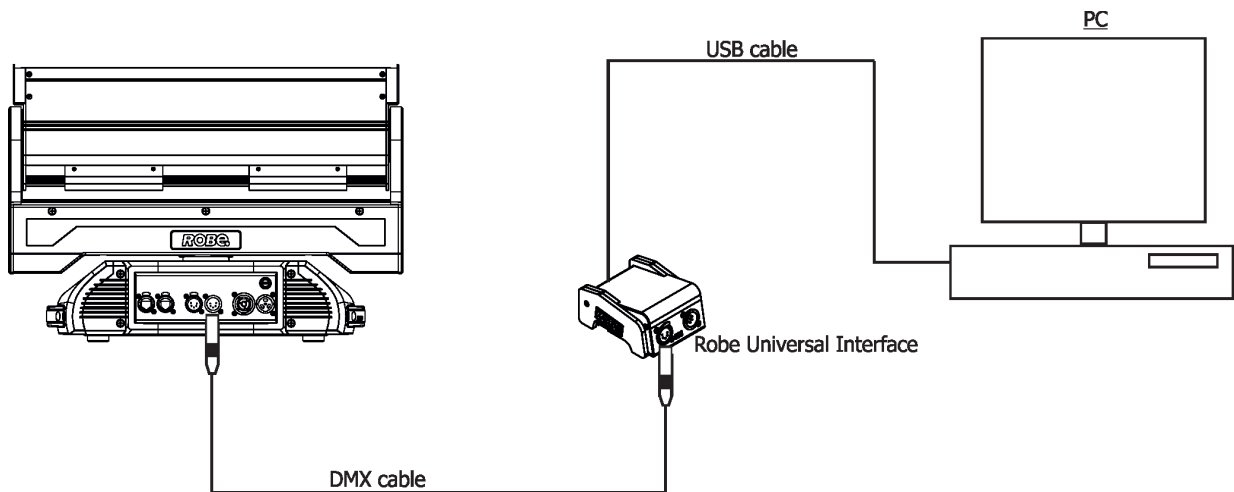

4. Switch the fixture to the update mode (Tab "Service" --> Update software).
 Note: If you do not want to continue in the software update, you have to switch off and on the fixture to escape from the updating mode.
 We recommend to cancel all running programs on your computer before starting the software uploader.
5. Double-click the software uploader file (e.g. DSU_RobinTetraX_18051638.exe) in the extracted files. The Software Uploader program will start running.

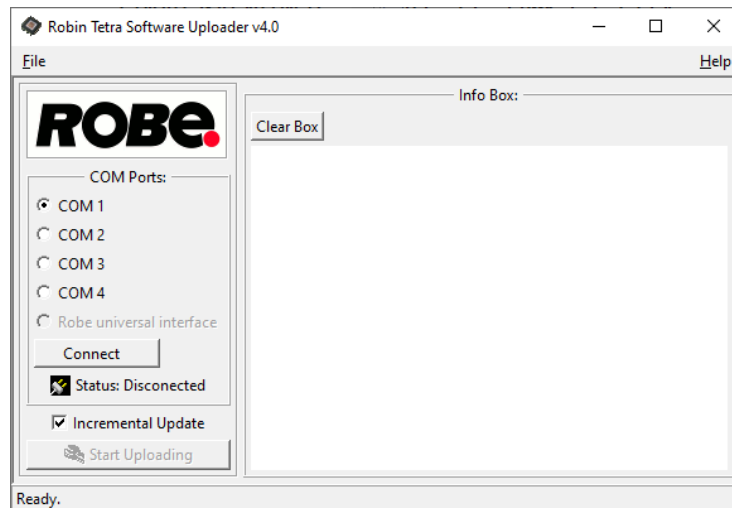

6. Select correct "COM " number if you use a Flash cable RS232/DMX or select "Robe Universal Interface " if you use the Robe Universal Interface/Robe Universal Interface WTX and then click on the "Connect" button.
 7. If the connection is OK, click the "Start Uploading" button to start software uploading. It will take several minutes to perform software update.
 If the option "Incremental Update" is not checked, all processors will be updated (including processors with the same software version).
 If you wish to update only processors with new version of software, check the "Incremental Update box".
 Avoid interrupting the process. Update status is being displayed in the "Info Box" window.
 When the update is finished, the line with the text "Fixture is successfully updated" will appear in this window.
- Note: After all processors updating, the fixture will be set to default values. If you use the Incremental update, setting the fixture to default values depends on type of updated processors.
 In case upload process is interrupted (e.g. power loss), the fixture stays in "Updating mode" and you will have to repeat the software update again.

Another way, how to update software in the fixtures (especially large installation of fixtures) is to use the ROBE Uploader. It is a software for automatized software update of Robe fixtures. It can take advantage of RDM support and Ethernet ports if present in the units.

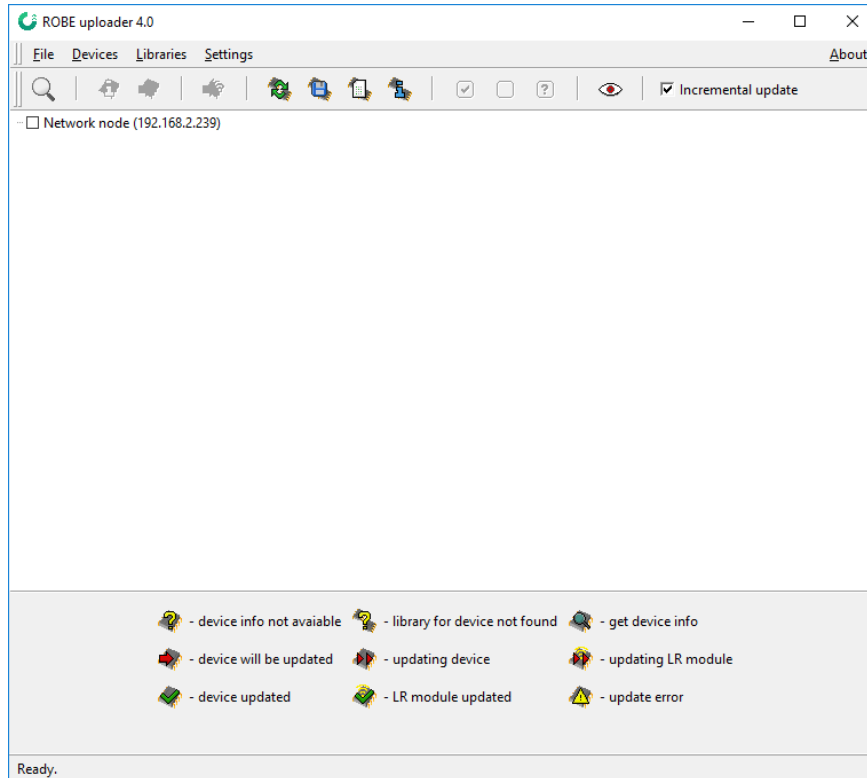

For more information please see <https://www.robe.cz/robe-uploader/>.

8. RDM

This fixture supports RDM operation. RDM (Remote Device Management) is a bi-directional communications protocol for use in DMX512 control systems, it is the new open standard for DMX512 device configuration and status monitoring.

The RDM protocol allows data packets to be inserted into a DMX512 data stream without adversely affecting existing non-RDM equipment. By using a special „Start Code,“ and by complying with the timing specifications for DMX512, the RDM protocol allows a console or dedicated RDM controller to send commands to and receive messages from specific moving lights.

RDM allows explicit commands to be sent to a device and responses to be received from it.

The list of commands for Robin TetraX is the following.

Parameter ID	Discovery command	SET command	GET command
DISC_UNIQUE_BRANCH	*		
DISC_MUTE	*		
DISC_UN_MUTE	*		
DEVICE_INFO			*
SUPPORTED_PARAMETERS			*
SOFTWARE_VERSION_LABEL			*
DMX_START_ADDRESS		*	*
IDENTIFY_DEVICE		*	*
DEVICE_MODEL_DESCRIPTION			*
MANUFACTURER_LABEL			*
DEVICE_LABEL		*	*
SENSOR_DEFINITION			*
SENSOR_VALUE			*
DISPLAY_INVERT		*	*
DISPLAY_LEVEL		*	*
TILT_INVERT		*	*
DEVICE_RESET		*	
DMX_PERSONALITY		*	*
DMX_PERSONALITY_DESCRIPTION			*
STATUS_MESSAGES			*
STATUS_ID_DESCRIPTION			*
DEVICE_HOURS ²			*
ROBE_DMX_INPUT		*	*
ROBE_WIRELESS_UNLINK		*	

²...Commands relative resetable values

RDM model ID for the Robin TetraX is 0x012a.

9. Robe Ethernet Access Portal (REAP)

The REAP allows you to display on your computer information about some fixture settings, operating conditions (e.g. temperature in the fixture) and error messages which were generated during fixture operation.

Your computer needs to be connected to the fixture(s) through the means of Ethernet wired network and a network switch.

The Ethernet network connection (Local LAN) typically needs to be set to 2.x.x.x address, assuming that no other computer on the network contains such an address while keeping all ROBE fixtures in default IP settings.

For more information about REAP options, computer and fixture settings please see the REAP user manual at https://www.robe.cz/res/downloads/user_manuals/User_manual_REAP.pdf.

10. Error and information messages

Information icon



- Air Filters Cleaning

This icon signals that cleaning period of the air filters has elapsed and you have to clear air filters and reset the menu item "Elapsed Time".

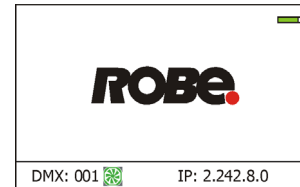

Errors

Error in the fixture is signalled by the yellow warning icon at the bottom line of the screen:



Touch the warning icon or press the [ESCAPE] button to display error messages.
List of error and information messages:

Temperature Sensor Error

The message informs you that the communication between the head temperature sensor and the main processor failed.

Tilt Error 1 (*Tilt Error 2*)

This message will appear after the reset of the fixture if the head's indexing circuit malfunctions (sensor failed) or the stepping motor or its driving PCB is defective. The head is not located in the default tilt position after fixture reset.

Pan Err 1 (*Pan Error 2*)

This message will appear after the reset of the fixture if the head's indexing circuit malfunctions (sensor failed) or the stepping motor or its driving PCB is defective. The head is not located in the default pan position after fixture reset.

EEprom Error

Hardware error of the EEPROM.

Recharge The battery

The battery on the display board needs to be charged. Let the fixture on about 6 hrs.

Battery faulty. Replace it.

The battery on the display board is exhausted and should be replaced immediately.

Clean Air Filters

The message informs that the item "Elapsed Time" in the "Fixture Information" menu is at 0 value. Clean air filter in the fixture base and reset this counter.

11. Technical Specifications

Electrical

Power supply: electronic auto-ranging
Input voltage range: 100-240V, 50-60Hz
Fuse: T 6.3A
Max. power consumption: 320W (power factor= 0.97)
Mains input: - max. 16A (US 13A)

Optic

Light source: 9 RGBW LED multichips
RGBW or CMY colour mixing
LED life expectancy: min. 50.000 hours
Typical lumen maintenance: L70/B50 @ 50.000 hours

Colour effects

Virtual colour wheel (66 preset colours)
Rainbow effect with in both directions with variable speed
CTC in range of 2700K-8000K
Halogen lamp effect at whites 2700K - 4200K

Zoom

Linear motorized zoom
Min. beam angle: 4°
Max. beam angle:45°

Multi-Coloured Flower Effect

3 x Multi-Coloured Flower Effect rotates in both directions at variable speed.

Strobe

Strobe effect with variable speed (0.3 - 20Hz)

Dimmer

Imperceptible 18 bit dimming for ultra smooth fade to black

Control

Graphic touch screen for fixture setting and addressing
Gravitation sensor for auto screen positioning
Battery backup of the touch screen
Readout fixture and LED module usage, receiving DMX values, temperatures, etc
Built-in analyzer for easy fault finding, error messages
Individual pixel control of each LED
Stand-alone operation
3 user editable programs, each up to 88 steps
Supported protocols: USITT DMX 512, RDM, ArtNet, MANet, MANet2, sACN, Kling-Net
Support of RDM (Remote Device Management)
6 DMX modes (42, 62, 76, 85, 89, 98 control channels)

Wireless DMX/RDM module RW 001 (only for Wireles DMX version of the fixture)

Supported protocols: full RDM support, CRMX , W-DMX™ G2, G3,G4 and G4S
Operational frequency range: 2402-2480 MHz
Output power: 100 mW
Receiver sensitivity (0.1% BER): -93 dBm
Crystal Clock Frequency : 16.0 MHz

Pan/Tilt

Pan movement range 540°/360°
Tilt movement range 191°
Continual pan rotation
16 bit movement resolution
Automatic pan/Tilt position correction
Remotely controllable speed of pan/tilt movement for easy programming
Pan-lock mechanism

Connection

DMX data in/out: Locking 5-pin XLR
AC power IN/Out : Neutrik power CON TRUE 1
Ethernet IN/Out: RJ45

Max. number of fixtures in Ethernet IN/Out line

8

Mounting

Attachment horizontally or vertically via two Omega mounting adaptors
Safety cable attachment point

Temperatures

Ambient temperature range : -5°C/+40° C
Maximum housing temperature : 70° C

Minimum distances

Min. distance from flammable surfaces: 0.5 m
Min. distance to lighted object: 1 m

Total heat dissipation (calculated)

Maximum: 818 BTU/hr

Protection factor

IP20

Weight

16.3 kg (35.9 lbs)

Accessories

1 x Power cable including powerCON TRUE1 In connector
1 x Omega adaptor CL regular (2 pcs in box)
1 x user manual

Optional accessories

Upgrade kit CRMX Universal 260 (P/N 99030100)
Safety wire 35 kg (P/N 99011963)
Daisy Chain powerCON TRUE1 In/Out, EU, 2m, Indoor (P/N 13052439)
Daisy Chain powerCON TRUE1 In/Out, US, 2m, Indoor (P/N 13052440)
Daisy Chain powerCON TRUE1 In/Out, EU, 5m, Indoor (P/N 13052444)

Dimensions (mm)

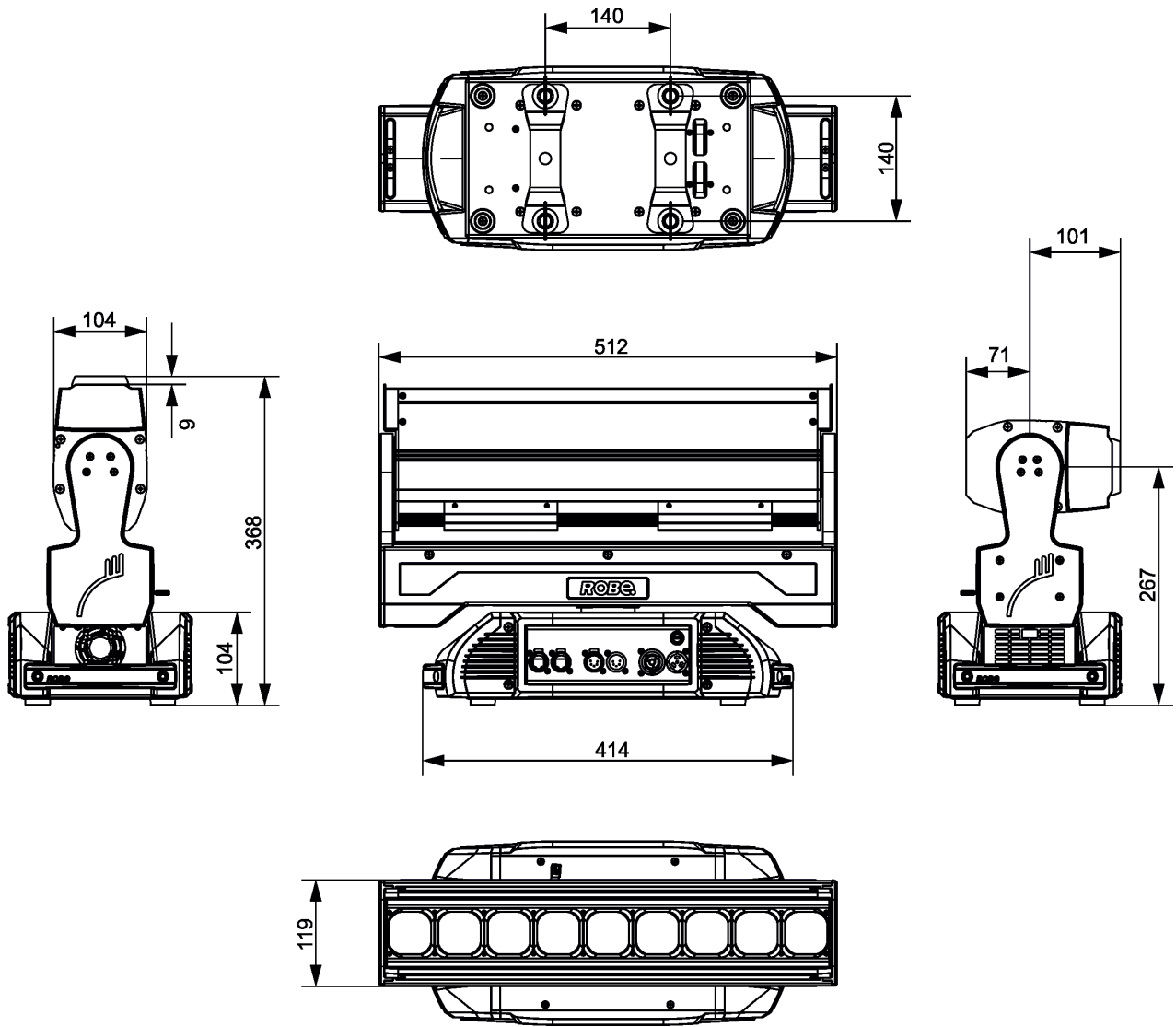

12. Maintenance and cleaning

It is absolutely essential that the fixture is kept clean and that dust, dirt and smoke-fluid residues must not build up on or inside optical system. Otherwise, the fixture's light output will be significantly reduced. Regular cleaning will not only ensure the maximum light output, but will also allow the fixture to function reliably throughout its life. A soft lint-free cloth moistened with any weak detergent solution is recommended for cleaning fixture's covers, under no circumstances should alcohol or solvents be used!

DANGER !
Disconnect from the mains before starting any maintenance and cleaning work.

The interior of the fixture should be cleaned at least annually using a vacuum cleaner or compressed air. The cooling fans in the base should be cleaned at least once a year.

Important! Never use alcohols (ethanol, methanol, isopropyl alcohol), acetone and another aggressive solvents for cleaning the LED lens array. Do not immerse lenses in liquid (e.g. water) during cleaning.

Recommended steps for cleaning the LED lens array:

1. Use low-pressure compressed air to remove coarse dust from lenses.
2. Use distilled water with weak detergent solution and lint-free small cloth for further cleaning of lenses.
3. Use an antistatic, alcohol-free screen cleaner (we recommend the Lyreco Screen Cleaner) and polish lenses until they are dry.
4. Check the lenses are dry before reapplying power.

Important! Check the air filter in the fixture base periodically and clean before they become clogged!

Periodically clean air filter placed in the fixture's base. The air filter cover is fastened by means of magnets. Use a vacuum cleaner, compressed air or you can wash them and put back dry. After replacing the air filter, reset the elapsed time counter in the menu "Information" (Information--->Air Filters---> Elapsed Time).

Replacing the fuse.

Before replacing the fuse, unplug mains lead.

1. Remove the fuse holder on the rear panel of the base with a fitting screwdriver from the housing (anti-clockwise).
2. Remove the old fuse from the fuse holder.
3. Install the new fuse in the fuse holder (only the same type and rating).
4. Replace the fuseholder in the housing and fix it.

Checking plastic parts of the fixture.

The plastic parts of the fixture should be checked for damages and beginning cracks at least every two months. If hint of a crack is found on some plastic part, do not use the fixture until the damaged part will be replaced. Cracks or another damages of the plastic parts can be caused by the fixture transportation or manipulation and also ageing process may influence plastic materials.

This checking is necessary for both fixed installations and preparing fixtures for renting. Any free moving parts inside of the fixture, cracked plastic or any plastic part not sitting properly in place need to be immediately replaced.

12.1 Removing the optical module

The following instructions are intended for service purposes only.

To remove the optical module from moving head

1. Connect the fixture to mains and after fixture reset go to the tab Manual Control, select item Zoom and set it at 0 DMX in order to slide the optical module (1) into the moving head.
2. Disconnect the fixture from mains.
3. Unscrew the two securing screws (2) on the guide-pins which prevent the optical module from sliding from the moving head. If you do not have access to the securing screws, carefully push the optical module (1) to the head. Do not touch the plastic lenses bare hands!
4. To make easier pulling the optical module (1) out of the moving head, screw two screws M3 (e.g. 30 mm long) (3) to the holes with M3 thread as shown on the picture below. The two screws help you to hold the optical module.
5. Carefully take the optical module (1) out of the moving head.

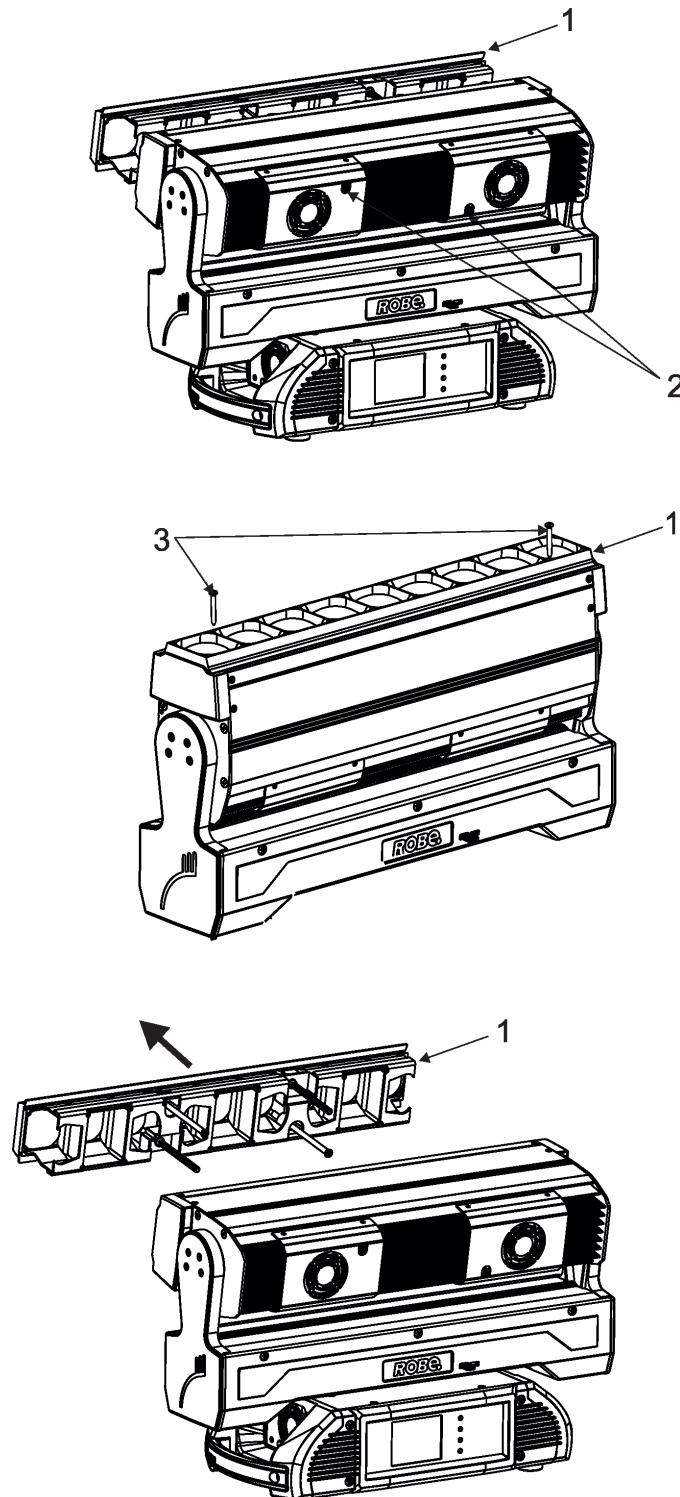

To insert the optical module back to the moving head

1. Connect the fixture to mains and after fixture reset go to the tab Manual Control, select item the Tilt and set it at 128 DMX and Zoom at 255 DMX.
2. Put one optical module (1) to the head in such a way that two guide-pins (5) aim into guide-tubes (7) and two lead screws (4) aim into motors (6).
3. Hold the optical module (1) in this position and slowly change the item Zoom from 255 DMX to 0 DMX. Motors "are pulling" the optical module into the head. If the optical module is not fully pulled into the head, carefully push the optical module into the head until you feel a stop. The optical module has to lay horizontally (it must not be askew).
To check the optical module movement, set the Zoom at 255 - 0 DMX a few times. The optical module has to move smoothly in both directions.
- 4 Set the Zoom at 0 DMX and disconnect the fixture from mains.
5. Screw the two securing screws (2) to the guide-pins (5) to secure optical module in the moving head.
DO NOT FORGET TO SCREW THE SECURING SCREWS (2) AND TO UNSCREW AUXILIARY SCREWS (3)! BEFORE CONNECTING THE FIXTURE TO MAINS!

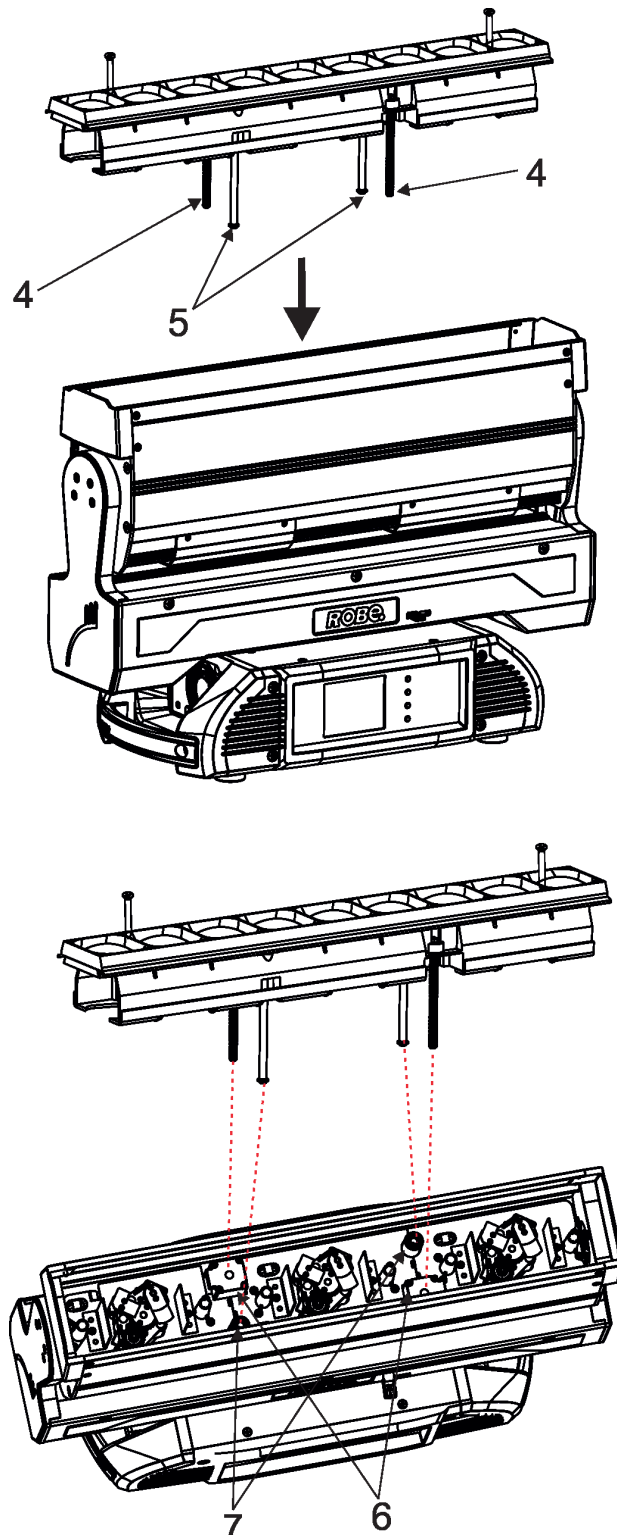

12.2 Disposing of the product

To preserve the environment please dispose or recycle this product at the end of its life according to the local regulations and codes.

12. ChangeLog

This section summarizes changes in the user manual.

Version of the manual	Date of issue	Description of changes
1.1	24/10/2022	DMX protocol ver.1.1
1.2	08/02/2023	Tilt movement range corrected
1.3	02/03/2023	Pixel calibration added
1.4	13/03/2023	Information about wireless DMX module added

14. Appendix - DMX modes overview

Pixel modes underlined

Mode	DMX Channels	Main Features
Mode 1	42	16-bit pan/tilt Selection of active zone (rings, sectors) 8-bit control of four individual colours (R,G,B,W) and Dimmer Flower effects control Without control of individual pixels.
Mode 2	62	16-bit pan/tilt Selection of active zone (rings, sectors) 16-bit control of four individual colours (R,G,B,W) and Dimmer Pixel patterns control (shape, repeat/size, rotation, transition, fade, crossfade, colour) Flower effects control Without control of individual pixels
<u>Mode 3</u>	76	16-bit pan/tilt Selection of active zone (rings, sectors) 16-bit control of four individual colours (R,G,B,W) and Dimmer Flower effects control Individual control of pixels (R,G,B)
<u>Mode 4</u>	85	16-bit pan/tilt Selection of active zone (rings, sectors) 16-bit control of four individual colours (R,G,B,W) and Dimmer Flower effects control Individual control of pixels (R,G,B,W)
<u>Mode 5</u>	89	16-bit pan/tilt Selection of active zone (rings, sectors) 16-bit control of four individual colours (R,G,B,W) and Dimmer Pixel patterns control (shape, repeat/size, rotation, transition, fade, crossfade, colour) Flower effects control Individual control of pixels (R,G,B)
<u>Mode 6</u>	98	16-bit pan/tilt Selection of active zone (rings, sectors) 16-bit control of four individual colours (R,G,B,W) and Dimmer Pixel patterns control (shape, repeat/size, rotation, transition, fade, crossfade, colour) Flower effects control Individual control of pixels (R,G,B,W)

June 28, 2024

Copyright © 2020-2024 Robe Lighting - All rights reserved

All Specifications subject to change without notice

Made in CZECH REPUBLIC by ROBE LIGHTING s.r.o. Palackeho 416/20 CZ 75701 Valasske Mezirici



DMX protocol

TetraX™ - DMX protocol								
Version: 1.2 Mode 1-Wash, Mode 2-Pattern, Mode 3-Pixel RGB, Mode 4-Pixel RGBW, Mode 5-Pattern full RGB, Mode 6-Pattern full RGBW								
Mode/Total channels						DMX Value	Function	Type of control
1/42	2/62	3/76	4/85	5/89	6/98			
1	1	1	1	1	1	0 - 255	Pan (8 bit) Pan movement by 540°/360° (128=default)	proportional
2	2	2	2	2	2	0 - 255	Pan Fine (16 bit) Fine control of pan movement (0=default)	proportional
3	3	3	3	3	3	0 - 255	Tilt (8 bit) Tilt movement by 191° (128=default)	proportional
4	4	4	4	4	4	0 - 255	Tilt fine (16 bit) Fine control of tilt movement (0=default)	proportional
5	5	5	5	5	5	0	Pan control Pan range 540°, shortcut Off (0=default)	step
						1	Pan range 360°, shortcut On	step
						2-127	No function (Pan range 540°, shortcut Off)	
						128-189	Continuous rotation fast -> slow , Forwards	proportional
						190-193	Stop rotation	step
						194-255	Continuous rotation slow -> fast , Backwards	proportional
6	6	6	6	6	6	0	Pan/Tilt speed , Pan/Tilt time Standard mode	step
						1	Max. Speed Mode	step
							Pan/Tilt speed mode	
						2 - 255	Speed from max. to min.	proportional
							Pan/Tilt time mode	
						2 - 255	Time from 0.2 s to 25.5 sec.	proportional
7	7	7	7	7	7	0 - 9	Power/Special functions Reserved (0=default) <i>To activate following functions, stop in DMX value for at least 3 s and shutter must be closed at least 3 sec. („Master Shutter/Strobe“ channel 40/59/46/46/59/59 must be at range: 0-31 DMX). Corresponding menu items are temporarily overridden (unless otherwise stated).</i>	
						10-14	DMX input: Wired DMX	step
						15-19	DMX input: Wireless DMX *	step
						20-24	Graphic display On	step
						25-29	Graphic display Off	step
						30-34	RGBW colour mixing mode	step
						35-39	CMY colour mixing mode	step
						40-44	Pan/Tilt speed mode	step
						45-49	Pan/Tilt time mode	step
						50-54	Blackout while pan/tilt moving	step
						55-59	Disabled blackout while pan/tilt moving	step
						60-64	Dimmer curve-square law	step
						65-69	Dimmer curve-linear	step
						70-74	Fans mode: Auto	step
						75-79	Fans mode: High	step
						80-84	White point 8000K On	step
						85-89	White point 8000K Off	step

DMX protocol

Mode/Total channels						DMX Value	Function	Type of control
1/42	2/62	3/76	4/85	5/89	6/98			
						90-94	Automatic white pixel On	step
						95-99	Automatic white pixel Off	step
						100-104	Quiet mode: Fans On at blackout	step
						105-109	Quiet mode: Fans Off at blackout	step
						110-114	Kling-Net On	step
						115-119	Kling-Net Off	step
						120-124	Parking position On	step
						125-129	Parking position Off	step
							<i>To activate following functions, stop in DMX value for at least 3 seconds (except Pixel index and Pixel mirror). Corresponding menu items are temporarily overridden.</i>	
						130 - 139	Fixture reset (except pan/tilt)	
						140 - 149	pan/Tilt reset	step
						150 - 159	Zoom reset	step
						160 - 169	Flower effects reset	step
						170-171	Tungsten effect simulation (750W) On **	step
						172-173	Tungsten effect simulation (1000W) On **	step
						174-175	Tungsten effect simulation (1200W) On **	step
						176-177	Tungsten effect simulation (2000W) On **	step
						178-179	Tungsten effect simulation (2500W) On **	step
						180-181	Tungsten effect simulation Off	step
						182-199	Reserved	
						200 - 209	Total fixture reset	step
						210-218	Pixel index	proportional
						219-227	Reserved	
						228-229	Pixel mirror On	step
						230-231	Pixel mirror Off	step
						232-236	Reserved	
						237	Save Pixel index and mirror to fixture	step
						238-239	Reserved	
						240	Disabled "Quiet mode"	step
						241 - 255	Quiet mode - fan noise control from min. to max.	proportional
8	8	8	8	8	8		LED frequency selection	
							Factory display menu setting: 300Hz	
							<i>Select PWM output frequency of LEDs. Selected PWM frequency can be fine adjusted in 127 steps up/down around selected PWM frequency on the channel below. Corresponding menu item (Frequency Setup) is temporarily overridden.</i>	
						0-4	PWM frequency from Display menu (fixture utilizes PWM frequency set in the display menu item Frequency Setup).	step
						5-9	300 Hz (5=default)	step
						10-14	Reserved	
						15-19	600 Hz	step
						20-255	Reserved (fixture utilizes PWM frequency set in the display menu item Frequency Setup).	
9	9	9	9	9	9		LED frequency fine adjusting	
							Factory display menu setting: 300Hz	
							<i>Select desired PWM output frequency of LEDs on the channel above.</i>	
						0-121	Selected LED Frequency	step

DMX protocol

Mode/Total channels						DMX Value	Function	Type of control
1/42	2/62	3/76	4/85	5/89	6/98			
						122	LED Frequency (step -6)	step
						123	LED Frequency (step -5)	step
						124	LED Frequency (step -4)	
						125	LED Frequency (step -3)	step
						126	LED Frequency (step -2)	step
						127	LED Frequency (step -1)	step
						128	Selected LED Frequency (128=default)	step
						129	LED Frequency (step +1)	step
						130	LED Frequency (step +2)	step
						131	LED Frequency (step +3)	step
						132	LED Frequency (step +4)	
						133	LED Frequency (step +5)	step
						134	LED Frequency (step +6)	step
						135-255	Selected LED Frequency	step
10	10	10	10	10	10		Background -Virtual colour wheel	
						0	No function (0=default)	step
						1-2	Filter 4 (Medium Bastard Amber)	step
						3-4	Filter 25 (Sunset Red)	step
						5-6	Filter 19 (Fire)	step
						7-8	Filter 26 (Bright Red)	step
						9-10	Filter 58 (Lavender)	step
						11-12	Filter 68 (Sky Blue)	step
						13-14	Filter 36 (Medium Pink)	step
						15-16	Filter 89 (Moss Green)	step
						17-18	Filter 88 (Lime Green)	step
						19-20	Filter 90 (Dark Yellow Green)	step
						21-22	Filter 49 (Medium Purple)	step
						23-24	Filter 52 (Light Lavender)	step
						25-26	Filter 102 (Light Amber)	step
						27-28	Filter 103 (Straw)	step
						29-30	Filter 140 (Summer Blue)	step
						31-32	Filter 124 (Dark Green)	step
						33-34	Filter 106 (Primary Red)	step
						35-36	Filter 111 (Dark Pink)	step
						37-38	Filter 115 (Peacock Blue)	step
						39-40	Filter 126 (Mauve)	step
						41-42	Filter 117 (Steel Blue)	step
						43-44	Filter 118 (Light Blue)	step
						45-46	Filter 122 (Fern Green)	step
						47-48	Filter 182 (Light Red)	step
						49-50	Filter 121 (Filter Green)	step
						51-52	Filter 128 (Bright Pink)	step
						53-54	Filter 131 (Marine Blue)	step
						55-56	Filter 132 (Medium Blue)	step
						57-58	Filter 134 (Golden Amber)	step
						59-60	Filter 135 (Deep Golden Amber)	step
						61-62	Filter 136 (Pale Lavender)	step
						63-64	Filter 137 (Special Lavender)	step

DMX protocol

Mode/Total channels						DMX Value	Function	Type of control
1/42	2/62	3/76	4/85	5/89	6/98			
						65-66	Filter 138 (Pale Green)	step
						67-68	Filter 798 (Chrysalis Pink)	step
						69-70	Filter 141 (Bright Blue)	step
						71-72	Filter 147 (Apricot)	step
						73-74	Filter 148 (Bright Rose)	step
						75-76	Filter 152 (Pale Gold)	step
						77-78	Filter 154 (Pale Rose)	step
						79-80	Filter 157 (Pink)	step
						81-82	Filter 143 (Pale Navy Blue)	step
						83-84	Filter 162 (Bastard Amber)	step
						85-86	Filter 164 (Flame Red)	step
						87-88	Filter 165 (Daylight Blue)	step
						89-90	Filter 169 (Lilac Tint)	step
						91-92	Filter 170 (Deep Lavender)	step
						93-94	Filter 172 (Lagoon Blue)	step
						95-96	Filter 194 (Surprise Pink)	step
						97-98	Filter 180 (Dark Lavender)	step
						99-100	Filter 181 (Congo Blue)	step
						101-102	Filter 197 (Alice Blue)	step
						103-104	Filter 201 (Full C.T. Blue)	step
						105-106	Filter 202 (Half C.T. Blue)	step
						107-108	Filter 203 (Quarter C.T. Blue)	step
						109-110	Filter 204 (Full C.T. Orange)	step
						111-112	Filter 219 (Fluorescent Green)	step
						113-114	Filter 206 (Quarter C.T. Orange)	step
						115-116	Filter 247 (Filter Minus Green)	step
						117-118	Filter 248 (Half Minus Green)	step
						119-120	Filter 281 (Three Quarter C.T. Blue)	step
						121-122	Filter 285 (Three Quarter C.T. Orange)	step
						123-124	Filter 352 (Glacier Blue)	step
						125-126	Filter 353 (Lighter Blue)	step
						127-128	Filter 507 (Madge)	step
						129-130	Filter 778 (Millennium Gold)	step
						131-132	Filter 793 (Vanity Fair)	step
						133-235	Raw DMX	proportional
						236-245	Rainbow effect (with fade time) from slow-> fast	proportional
						246-255	Rainbow effect (without fade time) from slow-> fast	proportional
11	11	11	11	11	11		Background - Red/Cyan (8 bit)***	
						0 - 255	Colour saturation control - coarse 0-100% (255=default)	proportional
*	12	12	12	12	12		Background - Red/Cyan (16bit)***	
						0 - 255	Colour saturation control - fine (255=default)	proportional
12	13	13	13	13	13		Background - Green/Magenta (8 bit)***	
						0 - 255	Colour saturation control - coarse 0-100% (255=default)	proportional
*	14	14	14	14	14		Background - Green/Magenta (16bit) ***	
						0 - 255	Colour saturation control - fine (255=default)	proportional
13	15	15	15	15	15		Background - Blue/Yellow (8 bit)***	
						0 - 255	Colour saturation control - coarse 0-100% (255=default)	proportional
*	16	16	16	16	16		Background - Blue/ Yellow (16bit)***	

DMX protocol

Mode/Total channels						DMX Value	Function	Type of control
1/42	2/62	3/76	4/85	5/89	6/98			
						0 - 255	Colour saturation control - fine (255=default)	proportional
14	17	17	17	17	17		Background - White (8 bit) - all pixels <i>If RGBW mode is selected:</i>	
						0-255	Colour saturation control - coarse 0-100% (255=default) <i>If CMY mode is selected:</i>	proportional
						0 - 255	No function	
*	18	18	18	18	18		Background - White (16 bit) - all pixels	
						0 - 255	Colour saturation control - fine (255=default)	proportional
15	19	19	19	19	19		Background - CTO	
						0-255	Col. temperature correction from 8000K to 2700K -for whites only (0=8000K, 64=5600K, 128=4200K, 192=3200K, 255=2700K) To get colour temperatures stated above, RGBW channels have to be set at the same value (e.g. 255DMX) or RGB=0 and White channel > 0 DMX (0=default) (To activate Tungsten effect at 2700K and 3200K , set DMX value at "Power/Special functions" channel)	proportional
16	20	20	20	20	20		Background - Shutter/ strobe	
						0 - 31	Shutter closed	step
						32 - 63	Shutter open (32=default)	step
						64 - 95	Strobe effect from slow to fast	proportional
						96 - 127	Shutter open	step
						128 - 143	Opening pulse in sequences from slow to fast	proportional
						144 - 159	Closing pulse in sequences from fast to slow	proportional
						160 - 191	Shutter open	step
						192 - 223	Random strobe effect from slow to fast	proportional
						224 - 255	Shutter open	step
17	21	21	21	21	21		Background - Dimmer intensity (8 bit)	
						0 - 255	Dimmer intensity from 0% to 100% (255=default)	proportional
*	22	22	22	22	22		Background Dimmer intensity - fine (16 bit)	
						0 - 255	Fine dimming (255=default)	proportional
18	23	23	23	23	23		Colour Mix control	
							<i>The channel defines relation between color channels</i>	
							<i>IF Flower effect is active, its colour channels always have priority!</i>	
							<i>Global = Global Colours (RGBW colours, Virtual Colour Wheel, CTO)</i>	
							<i>Pixel = Pixel Colours (RGB individual pixels or Kling-Net)</i>	
						0-9	Global colours (Global has priority)	
						10-19	Maximum mode (highest values have priority)	step
						20-29	Minimum mode (lowest values have priority)	step
						30-39	Multiply mode (multiply Global and Pixel)	step
						40-49	Addition mode (Global + Pixel) (45=default)	step
						50-59	Subtraction mode (Global – Pixel)	step
						60-69	Inverted Subtraction mode (Pixel – Global)	step
						70-79	Coloured background	step
						80-127	Raw DMX	proportional
						128	Global colours only (Global has priority)	step
						129-254	Crossfade (crossfade between Global and Pixel)	proportional
						255	Pixel colours (Pixel has priority)	step
19	24	24	24	24	24		Flower Effect 1	

DMX protocol

Mode/Total channels						DMX Value	Function	Type of control
1/42	2/62	3/76	4/85	5/89	6/98			
						0	Open position-without Flower Effect (0=default)	step
						1 - 127	Flower Effect forwards rotation from fast to slow	proportional
						128	Flower Effect -without rotation	step
						129-255	Backwards rotation from slow to fast	proportional
20	25	25	25	25	25		Flower Effect 1 - Red/Cyan (8 bit)	
						0 - 255	Colour saturation control - coarse 0-100% (255=default)	proportional
21	26	26	26	26	26		Flower Effect 1 - Green/Magenta (8 bit)	
						0 - 255	Colour saturation control - coarse 0-100% (255=default)	proportional
22	27	27	27	27	27		Flower effect 1 - Blue/Yellow (8 bit)	
						0 - 255	Colour saturation control - coarse 0-100% (255=default)	proportional
23	28	28	28	28	28		Flower Effect 1 - White (8 bit)	
						0-255	Colour saturation control - coarse 0-100% (255=default)	proportional
24	29	29	29	29	29		Flower Effect 1 - Shutter/ strobe	
						0 - 31	Shutter closed	step
						32 - 63	Shutter open (32=default)	step
						64 - 95	Strobe-effect from slow to fast	proportional
						96 - 127	Shutter open	step
						128 - 143	Opening pulse in sequences from slow to fast	proportional
						144 - 159	Closing pulse in sequences from fast to slow	proportional
						160 - 191	Shutter open	step
						192 - 223	Random strobe-effect from slow to fast	proportional
						224 - 255	Shutter open	step
25	30	30	30	30	30		Flower Effect 1 - Dimmer intensity (8 bit)	
						0 - 255	Dimmer intensity from 0% to 100% (255=default)	proportional
26	31	31	31	31	31		Flower Effect 2	
						0	Open position-without Flower Effect (0=default)	step
						1 - 127	Flower Effect forwards rotation from fast to slow	proportional
						128	Flower Effect -without rotation	step
						129-255	Backwards rotation from slow to fast	proportional
27	32	32	32	32	32		Flower Effect 2 - Red/Cyan (8 bit)	
						0 - 255	Colour saturation control - coarse 0-100% (255=default)	proportional
28	33	33	33	33	33		Flower Effect 2 - Green/Magenta (8 bit)	
						0 - 255	Colour saturation control - coarse 0-100% (255=default)	proportional
29	34	34	34	34	34		Flower effect 2 - Blue/Yellow (8 bit)	
						0 - 255	Colour saturation control - coarse 0-100% (255=default)	proportional
30	35	35	35	35	35		Flower Effect 2 - White (8 bit)	
						0-255	Colour saturation control - coarse 0-100% (255=default)	proportional
31	36	36	36	36	36		Flower Effect 2 - Shutter/ strobe	
						0 - 31	Shutter closed	step
						32 - 63	Shutter open (32=default)	step
						64 - 95	Strobe-effect from slow to fast	proportional
						96 - 127	Shutter open	step
						128 - 143	Opening pulse in sequences from slow to fast	proportional
						144 - 159	Closing pulse in sequences from fast to slow	proportional
						160 - 191	Shutter open	step
						192 - 223	Random strobe-effect from slow to fast	proportional
						224 - 255	Shutter open	step
32	37	37	37	37	37		Flower Effect 2 - Dimmer intensity (8 bit)	

DMX protocol

Mode/Total channels						DMX Value	Function	Type of control
1/42	2/62	3/76	4/85	5/89	6/98			
						0 - 255	Dimmer intensity from 0% to 100% (255=default)	proportional
33	38	38	38	38	38		Flower Effect 3	
						0	Open position-without Flower Effect (0=default)	step
						1 - 127	Flower Effect forwards rotation from fast to slow	proportional
						128	Flower Effect -without rotation	step
						129-255	Backwards rotation from slow to fast	proportional
34	39	39	39	39	39		Flower Effect 3 - Red/Cyan (8 bit)	
						0 - 255	Colour saturation control - coarse 0-100% (255=default)	proportional
35	40	40	40	40	40		Flower Effect 3 - Green/Magenta (8 bit)	
						0 - 255	Colour saturation control - coarse 0-100% (255=default)	proportional
36	41	41	41	41	41		Flower effect 3 - Blue/Yellow (8 bit)	
						0 - 255	Colour saturation control - coarse 0-100% (255=default)	proportional
37	42	42	42	42	42		Flower Effect 3 - White (8 bit)	
						0-255	Colour saturation control - coarse 0-100% (255=default)	proportional
38	43	43	43	43	43		Flower Effect 3 - Shutter/ strobe	
						0 - 31	Shutter closed	step
						32 - 63	Shutter open (32=default)	step
						64 - 95	Strobe-effect from slow to fast	proportional
						96 - 127	Shutter open	step
						128 - 143	Opening pulse in sequences from slow to fast	proportional
						144 - 159	Closing pulse in sequences from fast to slow	proportional
						160 - 191	Shutter open	step
						192 - 223	Random strobe-effect from slow to fast	proportional
						224 - 255	Shutter open	step
39	44	44	44	44	44		Flower Effect 3 - Dimmer intensity (8 bit)	
						0 - 255	Dimmer intensity from 0% to 100% (255=default)	proportional
40	45	45	45	45	45		Zoom	
						0-255	Zoom from max. to min.beam angle (128=default)	proportional
*	46	46	46	46	46		Zoom - fine	
						0-255	Fine zooming (0=default)	proportional
*	47	*	*	47	47		Pattern selection	
						0-2	No pattern (0=default)	
						3-4	Pattern 1	step
						5-6	Pattern 2	step
						7-8	Pattern 3	step
						9-10	Pattern 4	step
						11-12	Pattern 5	step
						13-14	Pattern 6	step
						15-16	Pattern 7	step
						17-18	Pattern 8	step
						19-20	Pattern 9	step
						21-22	Pattern 10	step
						23-24	Pattern 11	step
						25-26	Pattern 12	step
						27-255	RAW DMX	proportional
*	48	*	*	48	48		Pattern - Repeat (Size)	
						0-2	Variant 1 (0=default)	step
						3-4	Variant 2	step

DMX protocol

Mode/Total channels						DMX Value	Function	Type of control
1/42	2/62	3/76	4/85	5/89	6/98			
						5-6	Variant 3	step
						7-8	Variant 4	step
						9-10	Variant 5	step
						11-12	Variant 6	step
						13-14	Variant 7	step
						15-16	Variant 8	step
						17-18	Variant 9	step
						19-20	Variant 10	step
						21-22	Variant 11	step
						23-24	Variant 12	step
						25-26	Variant 13	step
						27-28	Variant 14	step
						29-30	Variant 15	step
						31-32	Variant 16	step
						33-34	Variant 17	step
						35-255	Raw DMX	proportional
*	49	*	*	49	49		Pattern - Movement	
						0	No movement	step
						1-127	Pattern movement from fast to slow	proportional
						128	Pause - without movement (128=default)	step
						129-255	Backwards pattern movement from slow to fast	proportional
*	50	*	*	50	50		Pattern - Fade	
						0	Snap (0=default)	step
						1-255	Fade from min. to max.	proportional
*	51	*	*	51	51		Pattern - Transition	
						0	No fade (0=default)	step
						1	100ms	step
						:		
						255	4 sec	step
*	52	*	*	52	52		Pattern - Crossfade	
						0	Background	step
						1-255	Crossfade between Background and Pattern 0-100% (255=default)	proportional
*	53	*	*	53	53		Pattern - Red (8-bit)	
						0 - 255	Colour saturation control - coarse 0-100% (255=default)	proportional
*	54	*	*	54	54		Pattern - Green (8-bit)	
						0 - 255	Colour saturation control - coarse 0-100% (255=default)	proportional
*	55	*	*	55	55		Pattern - Blue (8-bit)	
						0 - 255	Colour saturation control - coarse 0-100% (255=default)	proportional
*	56	*	*	56	56		Pattern - White (8-bit)	
						0 - 255	Colour saturation control - coarse 0-100% (255=default)	proportional
*	57	*	*	57	57		Pattern - Colour macro	
						0-2	No macro (0=default) <i>Macros 2-23 allow control of colour change speed from max. to min.</i>	step
						3-8	Macro 1	step
						9-14	Macro 2	proportional
						15-20	Macro 3	proportional
						21-26	Macro 4	proportional

DMX protocol

Mode/Total channels						DMX Value	Function	Type of control
1/42	2/62	3/76	4/85	5/89	6/98			
						27-32	Macro 5	proportional
						33-38	Macro 6	proportional
						39-44	Macro 7	proportional
						45-50	Macro 8	proportional
						51-56	Macro 9	proportional
						57-62	Macro 10	proportional
						63-68	Macro 11	proportional
						69-74	Macro 12	proportional
						75-80	Macro 13	proportional
						81-86	Macro 14	proportional
						87-92	Macro 15	proportional
						93-98	Macro 16	proportional
						99-104	Macro 17	proportional
						105-110	Macro 18	proportional
						111-116	Macro 19	proportional
						117-122	Macro 20	proportional
						123-128	Macro 21	proportional
						129-134	Macro 22	proportional
						135-140	Macro 23	proportional
						141-255	Raw DMX	proportional
*	58	*	*	58	58		Pattern - Shutter/ strobe	
						0 - 31	Shutter closed	step
						32 - 63	Shutter open (32=default)	step
						64 - 95	Strobe effect from slow to fast	proportional
						96 - 127	Shutter open	step
						128 - 143	Opening pulse in sequences from slow to fast	proportional
						144 - 159	Closing pulse in sequences from fast to slow	proportional
						160 - 191	Shutter open	step
						192 - 223	Random strobe effect from slow to fast	proportional
						224 - 255	Shutter open	step
*	59	*	*	59	59		Pattern - Dimmer intensity (8 bit)	
						0 - 255	Dimmer intensity from 0% to 100% (255=default)	proportional
41	60	47	47	60	60		Master Shutter/ strobe	
						0 - 31	Shutter closed	step
						32 - 63	Shutter open (32=default)	step
						64 - 95	Strobe effect from slow to fast	proportional
						96 - 127	Shutter open	step
						128 - 143	Opening pulse in sequences from slow to fast	proportional
						144 - 159	Closing pulse in sequences from fast to slow	proportional
						160 - 191	Shutter open	step
						192 - 223	Random strobe effect from slow to fast	proportional
						224 - 255	Shutter open	step
42	61	48	48	61	61		Master Dimmer intensity (8 bit)	
						0 - 255	Dimmer intensity from 0% to 100% (0=default)	proportional
*	62	49	49	62	62		Master Dimmer intensity - fine (16 bit)	
						0 - 255	Fine dimming (0=default)	proportional
*	*	50	50	63	63		Red pixel 1	
						0-255	Red LED saturation control 0-100% (0=default)	proportional

DMX protocol

Mode/Total channels						DMX Value	Function	Type of control
1/42	2/62	3/76	4/85	5/89	6/98			
*	*	51	51	64	64		Green pixel 1	
						0-255	Green LED saturation control 0-100% (0=default)	proportional
*	*	52	52	65	65		Blue pixel 1	
						0-255	Blue LED saturation control 0-100% (0=default)	proportional
*	*	*	53	*	66		White pixel 1	
						0-255	White LED saturation control 0-100% (0=default)	proportional
							:	
*	*	74	82	87	95		Red pixel 9	
						0-255	Red LED saturation control 0-100% (0=default)	proportional
*	*	75	83	88	96		Green pixel 9	
						0-255	Green LED saturation control 0-100% (0=default)	proportional
*	*	76	84	89	97		Blue pixel 9	
						0-255	Blue LED saturation control 0-100% (0=default)	proportional
*	*	*	85	*	98		White pixel 9	
						0-255	White LED saturation control 0-100% (0=default)	proportional
* function is active only 10 seconds after switching the fixture on								
** In the Tungsten effect simulation the Dimmer channel imitates behaviour of the halogen lamp during dimming								
*** Select RGB or CMY mixing mode on channel "Power/Special functions"								
Copyright ©2022-2023 Robe Lighting s.r.o. - All rights reserved								

Robin Tetra X - colours on Virtual Colour Wheel				
Colour name	Red (DMX)	Green (DMX)	Blue (DMX)	White (DMX)
Filter 4 (Medium Bastard Amber)	255	118	0	109
Filter 25 (Sunset Red)	255	50	0	3
Filter 19 (Fire)	255	13	0	0
Filter 26 (Bright Red)	255	0	0	0
Filter 58 (Lavender)	117	0	97	110
Filter 68 (Sky Blue)	42	195	100	0
Filter 36 (Medium Pink)	255	74	8	24
Filter 89 (Moss Green)	69	245	0	3
Filter 88 (Lime Green)	187	226	0	0
Filter 90 (Dark Yellow Green)	0	255	1	0
Filter 49 (Medium Purple)	255	0	27	0
Filter 52 (Light Lavender)	227	86	14	134
Filter 102 (Light Amber)	233	164	0	0
Filter 103 (Straw)	207	137	0	33
Filter 140 (Summer Blue)	0	161	7	218
Filter 124 (Dark Green)	29	255	0	12
Filter 106 (Primary Red)	242	1	1	0
Filter 111 (Dark Pink)	255	67	11	49
Filter 115 (Peacock Blue)	0	255	28	41
Filter 126 (Mauve)	255	0	39	0
Filter 117 (Steel Blue)	163	255	14	161
Filter 118 (Light Blue)	0	255	61	34
Filter 122 (Fern Green)	98	255	3	2
Filter 182 (Light Red)	255	16	2	0
Filter 121 (Filter Green)	165	255	0	0
Filter 128 (Bright Pink)	255	0	13	32
Filter 131 (Marine Blue)	73	245	27	30
Filter 132 (Medium Blue)	0	193	113	0
Filter 134 (Golden Amber)	191	83	0	0
Filter 135 (Deep Golden Amber)	255	52	0	0
Filter 136 (Pale Lavender)	164	96	29	54
Filter 137 (Special Lavender)	130	60	63	102
Filter 138 (Pale Green)	226	255	0	51
Filter 798 (Chrysalis Pink)	49	0	98	14
Filter 141 (Bright Blue)	8	176	62	0
Filter 147 (Apricot)	215	104	0	15
Filter 148 (Bright Rose)	255	3	0	37
Filter 152 (Pale Gold)	202	115	0	39
Filter 154 (Pale Rose)	214	107	0	48
Filter 157 (Pink)	255	56	5	48
Filter 143 (Pale Navy Blue)	0	193	72	148
Filter 162 (Bastard Amber)	223	153	6	41
Filter 164 (Flame Red)	255	27	0	4
Filter 165 (Daylight Blue)	23	236	87	81
Filter 169 (Lilac Tint)	206	123	0	110
Filter 170 (Deep Lavender)	235	123	41	33
Filter 172 (Lagoon Blue)	0	255	54	0

Colour name	Red (DMX)	Green (DMX)	Blue (DMX)	White (DMX)
Filter 194 (Surprise Pink)	110	0	21	255
Filter 180 (Dark Lavender)	136	43	181	89
Filter 181 (Congo Blue)	37	0	255	0
Filter 197 (Alice Blue)	107	220	129	0
Filter 201 (Full C.T. Blue)	179	255	57	34
Filter 202 (Half C.T. Blue)	217	255	37	3
Filter 203 (Quarter C.T. Blue)	236	255	30	3
Filter 204 (Full C.T. Orange)	230	125	3	7
Filter 219 (Fluorescent Green)	99	148	16	50
Filter 206 (Quarter C.T. Orange)	204	140	0	57
Filter 247 (Filter Minus Green)	255	81	0	193
Filter 248 (Half Minus Green)	255	144	0	137
Filter 281 (Three Quarter C.T. Blue)	225	255	72	160
Filter 285 (Three Quarter C.T. Orange)	199	124	0	17
Filter 352 (Glacier Blue)	0	161	65	90
Filter 353 (Lighter Blue)	0	115	37	97
Filter 507 (Madge)	255	31	0	0
Filter 778 (Millennium Gold)	255	65	0	0
Filter 793 (Vanity Fair)	255	0	13	16